



City of Muscatine

CITY COUNCIL

Tuesday, February 3, 2026

Brad Bark, Mayor

Don Lampe, 1st Ward

Jeff Osborne, 2nd Ward

Peggy Gordon, 3rd Ward

Nadine Brockert, 4th Ward

John Jindrich, 5th Ward

Angie Lewis, At Large

Matt Conard, At Large

Matt Mardesen, City Administrator

Cinda Hilger, City Clerk

Brent Hinders, City Attorney

City Council meetings are held at 5:30 p.m. on the 1st and 3rd Tuesday of each month. In-depth sessions will be held as needed at 5:30 p.m. on the 2nd Tuesday of each month. All meetings are available for review on the City of Muscatine YouTube page.

February 3, 2026, 5:30 PM

AGENDA

1. **CALL TO ORDER**
2. **INVOCATION - Fr. Chris Weber, Saints Mary & Mathias**
3. **ROLL CALL**
4. **PLEDGE OF ALLEGIANCE**
5. **FROM THE MAYOR**

A. Proclamation for Teen Dating Violence Awareness Month

6. **APPROVAL OF AGENDA AS PRESENTED AND/OR AS AMENDED**

7. **COMMUNICATIONS - CITIZENS**

8. **COUNCILMEMBER FOLLOW UP TO CITIZEN COMMUNICATION**

9. **CONSENT AGENDA * (ITEMS 10-14)**

The following items are considered to be routine by the City Council and will be enacted by one motion. There will be no separate discussion of these items unless a Council Member so requests, in which event the item will be removed from the Consent Agenda and considered separately.

10. *** REVIEW AND POTENTIAL VOTE TO APPROVE MINUTES**

A. January 20, 2026 City Council Regular Session Minutes

11. *** PETITIONS AND COMMUNICATIONS**

A. Request to Approve Use of City Property - Week Park - Melon City Criterium - Greg Harper

B. Request to Approve the Use of City Property - 2nd Street from Pine to Chestnut - Music Event - Skinny's Barbeque

C. Request to Approve Street Closure on Leroy Street from Mulberry to Orange for Tree Trimming

D. Liquor License:

1. Request for renewal of a Class "B" Retail Alcohol License for Dollar General #19625, 807

Grandview Avenue – DOLGENCORP LLC (pending inspections)

2. Request for renewal of a Class "E" Retail Alcohol License for Fareway Stores, Inc. #998,

2100 Cedar Plaza Drive – Fareway Stores Inc. (pending inspections)

12. *** COMMUNICATION – RECEIVE AND FILE**

A. January 12, 2026, Muscatine County Board of Supervisors Meeting Minutes

B. January 13, 2026, Muscatine County Board of Supervisors Meeting Minutes

C. November 19, 2026 Library Trustees Meeting Minutes

D. January 19, 2026 Muscatine County Board of Supervisors Meeting Minutes

- E. January 20, 2026 Muscatine County Board of Supervisors Meeting Minutes
- F. July 2025 - November 2025 City of Muscatine Monthly Financial Reports
- G. December 2025 Financial Statements -Muscatine Power and Water

13. * PURCHASE ORDERS AND AGREEMENTS

- A. Request to Approve Mutual Aid Agreement with Wilton Fire Department
- B. Request to Approve the Issuance of a Purchase Order in the Amount of \$13,800.00 to Muscatine County Abstract for Property Title Searches on the West Hill Sewer Separation Phase 6E Project.

14. * APPROVAL OF BILLS

It is recommended bills totaling \$2,204,287.20, be approved and that the City Council authorize the Mayor and City Clerk to issue warrants for the same. It should be noted that this listing is subject to the approval of any related agenda item(s).

- A. February 3, 2026 Bills for Approval

15. PUBLIC HEARING

16. FROM THE CITY ADMINISTRATOR

- A. Resolutions Accepting the Transfer of Five (5) County Held Tax Sale Certificates and Authorization to Pursue Obtaining Tax Sale Deeds
 - I Resolution Accepting the Tax Sale Certificate for 1114 Nebraska
 - II Resolution Accepting the Tax Sale Certificate for 1815 Schley
 - III Resolution Accepting Tax Sale Certificate for Parcel ID 0825154030
 - IV Resolution Accepting Tax Sale Certificate for 2003 Breese
 - V Resolution Accepting Tax Sale Certificate for 1805 Bryan Ave
- B. Resolution Setting a Public Hearing For February 17, 2026, on a Proposal to Enter into a Sewer Revenue Loan and Disbursement Agreement and to Borrow Money Thereunder in a Principal Amount not to Exceed \$3,380,000 (Planning and Design Loan)
- C. Resolution Approving Amended Development Agreement with Merge, LLC
- D. Resolution Expressing Intent to Provide Financial Support to Kraft Heinz Foods Company
- E. Resolution Accepting Completed Work by Keokuk Construction, Inc, for the Houser Lift Station Renovation Project and Authorizing Final Payment in the Amount of \$10,030.15.

- F. Request to Approve the Issuance of a Purchase Order to Pearl City Hardwoods for the Purchase of a Customer Counter in the Finance Department
- G. Request to Approve Subgrant Agreements for the Paul Bruhn Grant
- H. Request to Approve Amendment #4 to the Lease Agreement for Farm Land on the Muscatine Municipal Airport Property.
- I. Request to Approve Issuance of a Purchase Order to Feld Fire for a Replacement Ambulance

17. STAFF, COUNCIL AND MAYOR REPORTS

- A. Department Update - Brian Stineman, Public Works

18. ADJOURNMENT

Proclamation

Teen Dating Violence Awareness Month

Whereas, February is recognized nationally as Teen Dating Violence Awareness Month, as a time to raise awareness about dating abuse among adolescents and to promote healthy, respectful relationships, and

Whereas, National data shows that approximately 1 in 3 teens in the United States experiences some form of dating abuse, including emotional, physical, sexual, or digital abuse, and

Whereas, Teen dating violence affects young people of all genders, identities, and backgrounds, and

Whereas, early education, community engagement, and supportive resources are critical to preventing dating violence and empowering youth to recognize unhealthy behaviors and seek help.

Now, therefore, I Brad Bark, Mayor of Muscatine, do hereby proclaim February 2026 as Teen Dating Violence Awareness Month, and encourage community members, schools, families, and organizations to join in promoting safe, respectful, and healthy relationships for all youth.

Brad Bark, Mayor

City of Muscatine, City Council Minutes, Tuesday January 20, 2026 – City Council Chambers

Mayor Bark called the City Council meeting for January 20, 2026, to order at 05:30 PM.

Ray Oehme gave the invocation.

Councilmembers Present: Brockert, Jindrich, Osborne(virtual), Gordon, Lewis, Lampe, Conard.

Pledge of Allegiance

From the Mayor:

Proclamation for Slavery and Human Trafficking Prevention Month Proclamation was read by the Mayor and accepted by Caroline Levine.

Approval of Agenda:

Assistant City Administrator Kies requested item 19A be pulled from this meeting and brought back at a future meeting. Gordon/Lewis moved to approve the agenda as amended. All ayes, Motion Passed.

Consent Agenda:

Lewis/Conard moved to approve the consent agenda including city Council Minutes (January 6 and January 13th meetings) Liquor License (GM Mini mart, Rose Bowl) Receive and File (Dec 29, January 2 and January 5 County Board of Supervisors Meeting Minutes) Purchase Orders (Heritage Monuments, Yeadon Domes, Martin & Whitacre) Approval to purchase Right A Way for West Hill Sewer and Memorandum of Understanding with Muscatine County Emergency Management, and January 20 bills totaling \$2,396,867.26. All ayes, motion passed.

From City Administrator:

Lewis/Gordon moved to adopt on third and final reading an Ordinance Amending Title 10 and Title 13 of City Code, to Reflect State Mandated Changes to the Regulation of Accessory Dwelling Units, Group Homes, and Manufactured Homes. All ayes, motion passed.

Gordon/Lampe moved to adopt a Resolution accepting completed work by Manatts, Inc for the Park Avenue four to three lane conversion project and authorizing the release of retainage. All ayes, motion passed.

Brockert/Jindrich moved to adopt a Resolution Authorizing Special Assessments for Unpaid Abatement Service Fees and Rental Housing Fees to Private Properties. All ayes, motion passed.

Lewis/Brockert moved to adopt a Resolution adopting the Muscatine County Emergency Plan as the City of Muscatine Emergency Plan. All ayes, motion carried.

Gordon/Lewis moved to approve a request for change order number 2 for the Mulberry Avenue Sidewalk Reconstruction Project, in the Amount of \$7,796.97. All ayes, motion passed.

Lewis/Gordon moved to approve a Request for Subgrant Agreements for the Paul Bruhn Grant. All ayes, motion passed.

Lewis/Gordon moved to approve a Request for a Membership Program at the Musco Sports Center. All ayes, motion passed.

Gordon/Lewis moved to enter closed session pursuant to Iowa Code Section 21.5.1 for City Administrator's Evaluation with Potential Action to Follow. All ayes, motion passed.

Gordon/Lampe moved to Exit Closed Session. Vote: Ayes 6, Nays - 0, Motion passed. (Councilmember Osborne did not participate in the closed session)

Councilmember Lewis moved to adjourn the meeting at 6:41 pm.

CITY OF MUSCATINE, BILLS FOR APPROVAL, 1/20/2026, General Fund , A Notch Above Tree Service 380 1 services, Advanced Business Systems Inc 23.47 2 services, Advanced Radiology S.C 330.57 1 services, Alliant Energy 6300.55 9 utilities, Amazon.Com 929.23 25 supplies, Arnold Motor Supply 570.47 7 supplies, Baker Melissa 75 1 uniform, Centurylink 85.55 1 phones, Credit Bureau Mortgage Svcs 10 1 services, Docushare Llc 1595.16 2 services, Dsi Medical Services Inc 487 1 services, Eagle Engraving 82.95 1 services, Eastern Iowa Light & Power Co 457.34 4 utilities, Ems Learning Resource Center 221 2 services, Equian Llc 190.19 10 services, Finn Susan 13.5 1 refund, Fire Service Training Bureau 100 1 services, Fry David 54.25 2 uniforms, Gatso Usa Inc. 8478 1 services, Goerdts Inspection & Consultation Services Llc 270 1 services, Gordon Flesch Company 110.43 1 services, Grainger Dept 802675066 16.46 1 parts, Hagens Logan 121.46 1 uniforms, Healing Pathway Therapy Llc 1037.4 2 services, Hoag Sandy 20 1 reimbursement, Iowa State University Extension & Outreach 320 1 services, Kellor & Kellor Landscape Inc 2331.49 33 services, Kelly Heating Cooling & Plbg 2705.91 1 services, Labone Inc 187 5 services, Lear Julie 348.65 12 reimbursement, Leland Lamp Machine Shop Inc 211.6 2 parts, Linder Tina 40 1 refund, Lupton & Toyne Printers 90 1 supplies, Marco 197.55 2 services, Matjucha Hovland Annette V 150 3 services, Menards (Musc) 1240.55 31 supplies, Mid-States Organized Crime Information Center 200 1 services, Midwest Alarm Services 1619 2 services, Mission Square 3750.28 1 services, Morning Sun Farm Implement Inc 474.74 1 services, Municipal Collections Of America Inc 686 1 services, Muscatine County Attorney 147.2 3 services, Muscatine Lawn & Power 135.71 3 parts, Muscatine Lumber 26.75 1 supplies, Muscatine Power & Water 1357.01 18 utilities, My-Lor Inc. 114.15 1 supplies, Napa Of Muscatine 56.59 1 supplies, Nimely Catherine 300 1 refund, Outdoor Recreation Products 54.74 1 parts, Pack-N-Ship 9.77 1 shipping, Perkins Daniel E 402 1 refund, Phelps Allison 400 1 services, Phelps Custom Image Wear 76.32 1 uniforms, Phelps The Uniform Specialists 256.29 8 services, Plumb Supply Company 97.02 5 services, Pomp'S Tire Service 356 1 supplies, Preferred Resource Network 6224.4 1 supplies, Ps3 Enterprises Inc. 23.57 1 services, Quad City Times & Musc Journal 1067.04 5 services, R & R Products Inc 227.2 4 parts, Raynor Door Co Inc Of The Quad Cities 901 3 equipment, Reliance Standard Life Ins Co 3707.16 62 services, Rieke Diana 17.5 1 reimbursement, Rivers Brianna 50 1 services, Roth Matthew 375 1 refund, Seibel Heather Michele 225 2 services, Sigourney Tractor & Implement Llc 954.69 5 parts, Smith Filter Corporation 1415.23 7 supplies, Spratt Oil Sales 649.25 1 supplies, Stanard & Associates Inc 144 1 services, Sycamore Printing Inc 69 2 supplies, Tantara Transportation Corp 465.73 1 services, Temple Jill 60 1 refund, The Hillman Group Inc 34.7 1 supplies, Tmesys Llc 360.89 2 services, Transunion Risk & Alternative 105 1 services, Ui Health Care Med Center 7939.34 12 services, Unique Management Services Inc 198.05 1 services, Unity Healthcare-Hospital 824 10 services, Us Cellular 296.08 2 phones, Van Meter Industrial Inc 0 2 return, Verizon 272.8 3 phone, Verizon Wireless 442.61 5 phone, Visa Tcm Bank Na 10762.63 65 supplies/services, Waack Kelly 60 2 refund, Xerox Corporation 1077.14 14 services, Zirous 1875 1 services, Grand Total 81126.31, , Capital Project Funds, Bolton & Menk Inc 16893.5 1 Services, Boulder Contracting Llc 5236.14 1 services, Esco Automation 6563 1 services, Hdr Engineering Inc 38521.17 1 services, Ke Flatwork Inc 53204.75 1 services, Manatts Inc.

6300 1 services, Prosource Technologies Llc 13398 1 services, Stanley Consultants Inc 36575.75 1 services, Van Meter Industrial Inc 2790.82 1 services, Grand Total 179483.13, , Enterprise Utility Funds, 3B Medical 1636.75 5 services, A-1 Quality Tire & Car Care 690.08 1 supplies, Alliant Energy 20155.46 13 utilities, Als Group Usa Corp 1068 1 services, Amazon.Com 2017.22 15 supplies, Arnold Motor Supply 189.43 3 parts, Bailey Logan 152.6 1 refund, Barnard Joe 77.01 1 uniform, Bound Tree Medical Llc 666.18 3 supplies, Brauns Jon 24465.4 3 services, Brauns Jon 41760 1 services, Calcott Chip 150 1 uniforms, Carquest Of Muscatine 75.37 1 supplies, Casini Kathleen 290 1 refund, Chapman Michael 61.05 1 refund, Clearly 194.05 1 phones, Coca-Cola Bottling Company 114.88 1 resale merch, Crawford Company Inc 16083.51 6 services, Diercks Mark A 24 1 supplies, Dsi Medical Services Inc 75 1 services, Eastern Iowa Light & Power Co 111.46 1 utilities, Ems Learning Resource Center 76.5 2 supplies, Fastenal Company 350.3 2 supplies, Feld Fire 59.35 1 part, Gordon Flesch Company 30.51 1 services, Harms Oil Company 12156.1 1 supplies, Hinckley Medical Inc 5495 1 services, Ican 406 1 services, Iowa One Calls 147.6 1 services, Lajek Pest Control Solutions Llc 48 1 services, Mailboxes & Parcel Depot 60.58 2 shipping, Mccracken Bill 47.02 1 uniforms, Mellen & Associates Inc 919.87 1 equipment, Menards (Musc) 506 6 supplie, Midland Scientific Inc 741.94 1 supplie, Mills Marine 16.99 1 part, Motion Industries Inc 187.21 2 part, Municipal Collections Of America Inc 161.31 1 services, Muscatine Power & Water 2645.17 20 utilities, Omnisite 304 1 services, Pack-N-Ship 132.58 1 shipping, Peiffer Jada 42.76 1 uniforms, Phelps The Uniform Specialists 378.31 5 Services, Plumb Supply Company 9.2 1 parts, Ps3 Enterprises Inc. 262.5 2 services, R & R Products Inc 68.35 1 parts, Reliance Standard Life Ins Co 2208.17 51 services, Republic Services Inc Republic Services Of Iowa Llc 35967.26 1 services, Riddell Roofing 375 1 services, S.J. Smith Co. 163.56 2 supplies, Safety Vision Llc 3558 1 services, Sign Works Of Muscatine Llc 2640 1 equipment, Sigourney Tractor & Implement Llc 226.44 1 supplies, Symmonds Lila 100 1 refund, T&T Hackett Development 400000 1 Grant Funds, Team Staffing Solutions Inc 469.6 3 services, Teleflex Llc 1330 2 equipment, T-Mobile 242.01 1 phones, Uline 5056.6 4 equipment, Us Cellular 51.16 1 phones, Usa Blue Book 400.29 1 supplies, Verizon 172.66 3 phones, Verizon Wireless 378.3 3 phones, Visa Tcm Bank Na 5186.38 26 supplies/service, Wallace Cranes 1505.33 1 equipment, Weikert Jr Michael 1206 4 services, Xerox Corporation 0.55 1 services, Grand Total 596547.91, , , Internal Service Funds , A-1 Quality Tire & Car Care 1191.42 14 parts/services, Amazon.Com 5.66 1 supplies, Arnold Motor Supply 3037.01 28 parts/supplies, Ascendance Trucks Llc 890 3 parts, Eastern Iowa Tire Inc 745.8 1 supplies, Elliott Equipment Company 236.62 2 parts, Excel Auto Glass Inc 542.74 1 parts, Grainger Dept 802675066 465.33 3 parts, Harms Oil Company 14854.22 1 supplies, Henderson Products Inc. 201.22 2 parts, Imwca 11242 1 services, Lawson Products Inc 151.17 1 supplies, Martin Equipment Of Ia-Ii Inc 46.33 3 parts, Menards (Musc) 61.17 2 supplies, Napa Of Muscatine 315.5 1 parts, Nash Keaton Butcher 625.49 2 services, Parts Authority 136.27 2 parts, Phelps Custom Image Wear 172.75 1 uniform, Reliance Standard Life Ins Co 361.25 14 services, Titan Machinery Inc 594.65 2 return, Truck Country Of Iowa 1066.18 3 parts, Truck Equipment 717.93 2 parts, Trucks Unlimited Inc 302 1 services, Verizon 51.15 2 phones, Visa Tcm Bank Na 1.26 1 subscription, Wellmark Blue Cross & Blue 45698.55 7 services, Xerox Corporation 9.35 4 services, Grand Total 83723.02, , Special Revenue Funds , Etienne Drew 6000 1 services, Labone Inc 37.4 1 services, Martin Gardner Architecture P.C. 1758.01 1 services, Muscatine Center Social Action 2858 1 services, Ngezahayo Josephine 1250 1 services, Noah Gabby 1250 1 services, Reliance Standard Life Ins Co 43.76 2 services, Sosa Tony 1250 1 services, Sycamore Printing Inc 280 1 supplies, Visa Tcm Bank Na 2270.63 4 supplies, Grand Total 16997.8, , Housing Funds , Advanced Business Systems Inc 7.82 1 services, Alliant Energy 3887.68 3 utilities,

Carver Construction 1050 2 services, City Of Cedar Rapids 47 1 services, City Of Muscatine Housing Revolving Fund 26031.09 42 services, Davis Kaitlyn 87.5 1 services, Diercks Mark A 34 1 supplies, Kelly Stephanie Sue 512 1 rent, Kelly Heating Cooling & Plbg 916.87 4 services', Menards (Musc) 1885.99 8 supplies, Muscatine Power & Water 2601.17 26 utilities, North Central Region Nahro 75 3 services, Pdq Supply Inc 116.69 3 parts, Plumb Supply Company 11.28 2 supplies, Tenant Reports.Com Llc 91 3 services, Thomas L Spann Jr & Sonya Colbert-Spann 7025 38 services, Us Cellular 107.26 2 phones, Van Meter Industrial Inc 92.7 1 equipment, Visa Tcm Bank Na 5317.45 13 supplies, Grand Total 49897.5 186, , , BILLS FOR APPROVAL SUMMARY, , Computer Bill Lists, Regular Bills 1/21/26 \$1, 007, 775.67, Special CK Run 1/21/26 Operating 35, 500.00, Payroll Vendor Checks 1/2/26 15, 832.53, Payroll Vendor Checks 1/16/26 43, 201.93, Payroll Vendor ACH Payments 1/2/26 99, 728.28, Payroll Vendor ACH Payments 1/16/26 99, 206.36, Subtotal \$1, 301, 244.77, , ACH Debit Memo Payments, Wellmark Insurance Health/Dental Insurance Jan \$83, 000.00, Wellmark Insurance Health/Dental Insurance Jan 83, 000.00, Payroll Account Transfer 475, 568.27, Treasurer State of Iowa State Tax Withholding 22, 886.44, IPERS December Contributions 129, 657.54, Internal Revenue Service Federal Withholding 122, 086.57, Subtotal \$916, 198.82, , , Voucher Program, Various Landlords Estimated February Rent \$180, 000.00, \$180, 000.00, , Voids, Void CK 1/14/26 Operating \$(576.33), Subtotal \$(576.33), , Total Expenditures \$2, 396, 867.26, , PAYROLL CHECKS POLICE & FIRE INS 194.94, PAYROLL CHECKS UNITED WAY 75.00, PAYROLL CHECKS AFA FLEX BILLING 4, 253.29, PAYROLL CHECKS AFLAC 525.88, PAYROLL CHECKS ALLSTATE 14.94, PAYROLL CHECKS AMERICAN FIDELITY 2, 444.45, PAYROLL CHECKS CITY OF MUSCATINE 33, 924.24, PAYROLL CHECKS IDAHO CHILD SUPPORT 99.12, PAYROLL CHECKS UNITED WAY 75.00, PAYROLL CHECKS VSP 1, 865.01, SPECIAL CHECKS JEREMY FERGUSON 500.00, SPECIAL CHECKS MUSCATINE CENTER SOCIAL ACTION 15, 000.00, SPECIAL CHECKS MUSCATINE CHAMBER 12, 500.00, SPECIAL CHECKS SENIOR RESOURCES 7, 500.00,

Submitted by:

Cinda Hilger, City Clerk

Attest:

Brad Bark, Mayor

License # _____
Wallet # _____
Sticker # _____
Receipt # _____
Issued _____
Expires _____

CITY OF MUSCATINE

**APPLICATION FOR USE OF ANY STREET, SIDEWALK, ROADWAY, ALLEY,
PARK, PUBLIC WAY, PROPERTY OR FACILITY**

1. Name and address of applicant and sponsoring organization, if any:

Greg Harper, Melon City Bike Club, inc.

Address: 619 Sunrise Circle, Muscatine, IA 52761

Telephone Number: 563-260-5393

E-mail Address: gharper59@gmail.com

2. Type of event that is planned:

46th Melon City Criterium

3. Proposed location:

Weed City Park

4. Date(s)/Time(s): Sunday, May 24, 2026

5. Expected length of use: 6am-6pm

6. Expected size of group: 1500

7. Names of any person or persons in charge of the proposed use at the specified location:

Greg Harper & Melon City Bike Club members

Address(es): 619 Sunrise Circle, Muscatine, IA 52761

Telephone Number(s): 563-260-5393

E-mail Address(es): gharper59@gmail.com

8. Names and addresses of any persons to be featured as entertainers or speakers:

Local and national individual bike racers from various states.

9. List mechanical or electronic equipment to be used:

Professional finishline stage with photo finish camera and announcer.

10. Number and type of any motor vehicles or other forms of transportation to be used, including bicycles, boats, carriages and golf carts:

one pace vehicle, two official motorcycle referees,

11. Number and types of animals to be used:

NA

12. A description of any sound amplification to be used:

Professional finishline stage for announcer.

13. Proposed monitoring of the group and/or activity including the number of people who will direct traffic, set up, clean up and maintain order, if necessary:

Melon City Bike Club members setup/ take down barricades at entrance to Weed park. City employees set out barricades near streets, park benches and trash cans moved to approved locations.

14. All plans for the provision of security:

Communicate with police via cell phone.

15. Beer or wine consumption? Yes _____ No X

16. Describe any items to be sold or distributed:

Local food trucks located with in Weed Park for spectators and competitors, with approved licenses.

17. Is water connection requested: Yes _____ No X

18. Is electricity requested: Yes X No _____

19. Have you provided a layout site plan for your proposed activity or event? Yes X No _____

If yes, please attach.

If no, please explain:

Same as 2025

20. Do you understand that you will be financially responsible for all site restoration needed to restore the side to pre-event status? Yes X No _____

The applicant agrees to indemnify, defend and save harmless the City of Muscatine, together with its agents, officers and employees, from any and all claims, lawsuits, damages, losses and expenses, of whatever nature, which may result from or arise from the activity or event covered by the permit, including but not limited to the use of public ways, irrespective of whether said claims are frivolous or meritorious.

Greg Harper

Authorized Representative

1/12/2026

Date

EVENT: Melon City Criterium

TO BE COMPLETED BY CITY DEPARTMENTS:

I have reviewed the attached application with the following recommendations:

Recommend
Approval

Comments:

YES NO

[Richard Klimes](#) Jan 19, 2026
Richard Klimes (Jan 19, 2026 16:56:46 CST)
Parks & Recreation Date

Approval subject to attendance at pre-event mtg

YES NO

[Brian Stineman](#) Jan 16, 2026
Brian Stineman (Jan 16, 2026 14:38:31 CST)
Community Development Date

YES NO

[Brian Stineman](#) Jan 19, 2026
Brian Stineman (Jan 19, 2026 10:23:16 CST)
Public Works Date

YES NO

[A.R. Kies](#) Jan 19, 2026
A.R. Kies (Jan 19, 2026 13:29:27 CST)
Police Chief Date

YES NO

[Michael A Hartman](#) Jan 19, 2026
Michael A Hartman (Jan 19, 2026 13:43:34 CST)
Fire Chief Date

FINAL APPROVAL:

YES NO

[Matthew T Mardesen](#) Jan 19, 2026
Matthew T Mardesen (Jan 19, 2026 17:15:58 CST)
City Administrator Date

Approval subject to attendance at pre-event mtg

✓ Lois Moss 563 264 1550

| | |
|-----------|-------|
| License # | _____ |
| Wallet # | _____ |
| Sticker # | _____ |
| Receipt # | _____ |
| Issued | _____ |
| Expires | _____ |

CITY OF MUSCATINE

**APPLICATION FOR USE OF ANY STREET, SIDEWALK, ROADWAY, ALLEY,
PARK, PUBLIC WAY, PROPERTY OR FACILITY**

1. Name and address of applicant and sponsoring organization, if any:

Skinnys Barbeque
 Address: 208 W 2nd Street
 Telephone Number: 563 261 7445
 E-mail Address: Skinnysbarbeque@gmail.com

2. Type of event that is planned:

Street Music fest. Community involvement.
Exposure of newly expanded Skinnys Barbeque.

3. Proposed location:

2nd Street.
Pine → Chestnut St.

4. Date(s)/Time(s): June 20th / 12pm - 11pm

5. Expected length of use: 19th & 20th (Set up) 8am

6. Expected size of group: ~~200~~ 500 + 1000 +

7. Names of any person or persons in charge of the proposed use at the specified location:

Cord Klust.
Chance Klust

Address(es): 208 W 2nd Street

Telephone Number(s): 563 261 7445

E-mail Address(es): skinnysbarbeque@gmail.com

8. Names and addresses of any persons to be featured as entertainers or speakers:

TBD.

9. List mechanical or electronic equipment to be used:

Stage Platform, ^{Sound} System

10. Number and type of any motor vehicles or other forms of transportation to be used, including bicycles, boats, carriages and golf carts:

N/A

11. Number and types of animals to be used:

N/A

12. A description of any sound amplification to be used:

PA System. Bands w/ Amps.
Directional speakers facing Chestnut St.
Sound engineer mix monitoring.

13. Proposed monitoring of the group and/or activity including the number of people who will direct traffic, set up, clean up and maintain order, if necessary:

~~Volunteer~~
Volunteer Committee, HS Football Team (10-15 people.)
Clean up, set up, & maintain plans ~~as per~~

14. All plans for the provision of security:

Hired Police Officers during evening hours (7 PM - 11 PM)
Hired Security on hand during day.

15. Beer or wine consumption? Yes No

16. Describe any items to be sold or distributed:

Beer, wine, crafts (vendors) food trucks.

17. Is water connection requested: Yes No

18. Is electricity requested: Yes No

19. Have you provided a layout site plan for your proposed activity or event? Yes No

If yes, please attach.

If no, please explain:

Stage & directional speakers near Pine St facing Chestnut St w/ the rest of the street for pedestrians to lounge & vendors to set up in the parking lot near Pine St. Roof Social will be selling alcohol to people ~~inside~~ inside & outside in face area?

20. Do you understand that you will be financially responsible for all site restoration needed to restore the site to pre-event status? Yes No

The applicant agrees to indemnify, defend and save harmless the City of Muscatine, together with its agents, officers and employees, from any and all claims, lawsuits, damages, losses and expenses, of whatever nature, which may result from or arise from the activity or event covered by the permit, including but not limited to the use of public ways, irrespective of whether said claims are frivolous or meritorious.

Authorized Representative

1/20/24
Date

EVENT: Skinny's BBQ Music Event

TO BE COMPLETED BY CITY DEPARTMENTS:

I have reviewed the attached application with the following recommendations:

Recommend
Approval

h YES NO

Richard Kilmes
Richard Kilmes (Jan 19, 2026 08:24:57 CST)
Parks & Recreation Date

Jan 19, 2026

Comments:

The form needs to be signed
Approval subject to attendance
at the pre-event mtg. *AK*

YES NO

[Signature]
[Signature] (Jan 15, 2026 18:02:07 CST)
Community Development Date

Jan 15, 2026

YES NO

Brian Steneman
Brian Steneman (Jan 16, 2026 08:22:55 CST)
Public Works Date

Jan 16, 2026

YES NO

A.R. Kies
A.R. Kies (Jan 16, 2026 13:27:12 CST)
Police Chief Date

Jan 16, 2026

YES NO

Michael A Hartman
Michael A Hartman (Jan 16, 2026 13:41:13 CST)
Fire Chief Date

Jan 16, 2026

FINAL APPROVAL:

YES NO

[Signature]
City Administrator Date

1-22-26



City of Muscatine

ITEM NUMBER 2026-0037

AGENDA ITEM SUMMARY

DATE: 2/3/2026

STAFF

Brian Stineman, Public Works Director

SUBJECT

Request to Approve Street Closure on Leroy Street from Mulberry to Orange for Tree Trimming

EXECUTIVE SUMMARY

Advantage Tree Service requests permission to close Leroy Street from Mulberry Avenue to Orange Street for tree trimming.

STAFF RECOMMENDATION

Staff recommends approval.

BACKGROUND/DISCUSSION

Advantage Tree Service plans to trim trees on Leroy Street from Mulberry Ave to Orange Street on February 12, 2026 from 8:30 a.m. to 3:00 pm and again on February 13, 2026 from 8:30 am to 3:00 pm. Bi-State Barricade will be responsible for traffic control and a detour will be in place on Orange Street and Woodlawn Avenue.

CITY FINANCIAL IMPACT

N/A

ATTACHMENTS

1. SCity of Mu26012308200



Request for Closure

1. Location of closure: Le Roy St
 - a. Road closed from: Mulberry Ave to Orange St
2. Contractor: Advantage Tree Service
3. Dates and duration of closure: 2/12/2026, 8:30 am - 3 pm
through 2/13/2026, 8:30 am - 3 pm
4. Company responsible for detour and signage: bistate barricade
5. Reason closure is needed: tree work (trimming)

Date submitted: 1/16/2026

Applicant: Hudson Bezotte

1919 Mulberry Ave

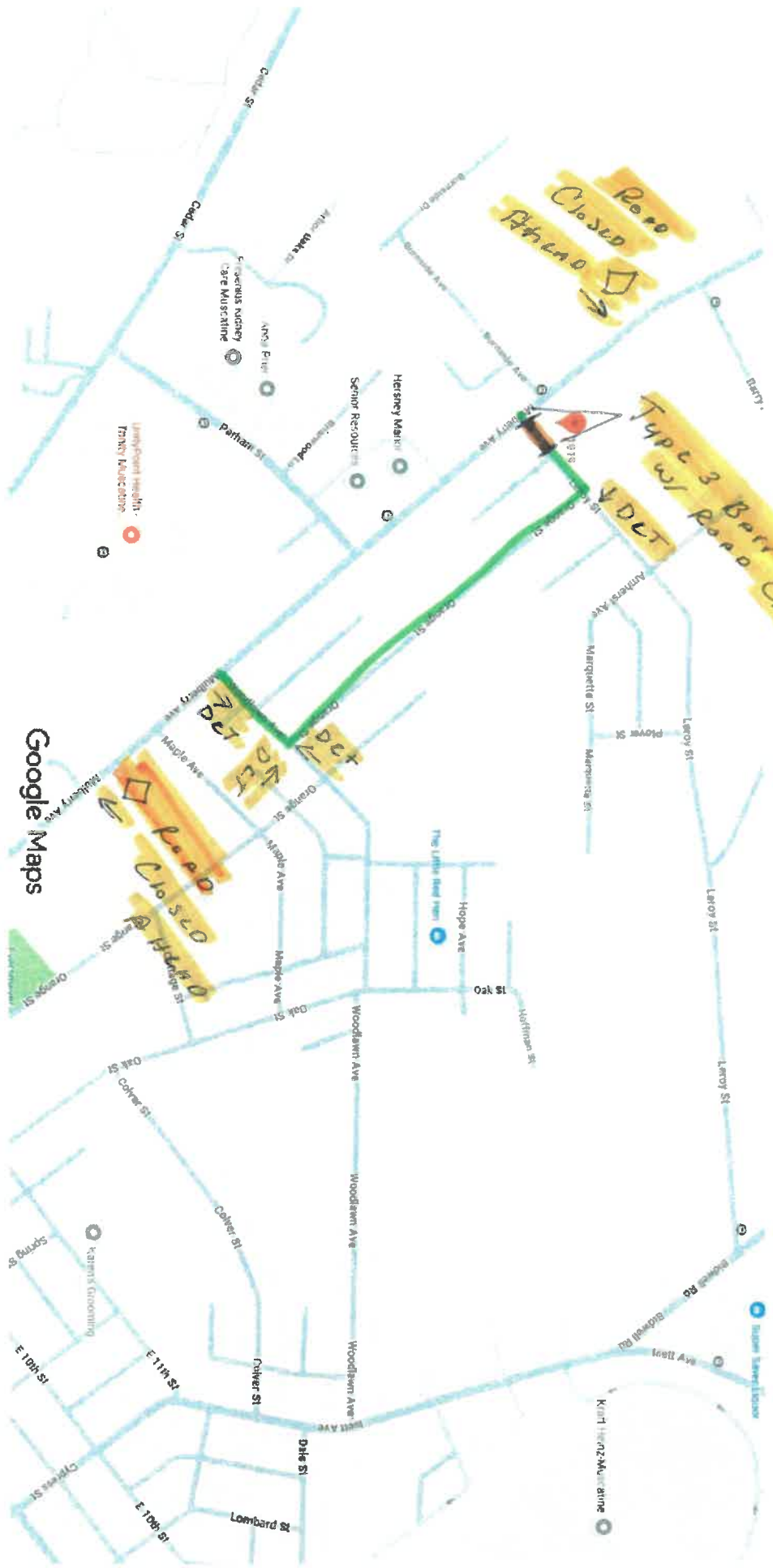

█ Detour Route
█ Work Zone

Muscatine County Board of Supervisors
Monday, January 12, 2026

The Muscatine County Board of Supervisors met in regular session at 9:00 A.M. with Chick, Kirchner, Sorensen and Sauer present. Mather was absent. Chairperson Chick presiding.

On a motion by Sorensen, second by Sauer, the agenda was approved as presented. Ayes: All.

County Sheriff Quinn Riess reviewed a request to purchase a 2024 Police Package Dodge Durango with funds in his current budget.

On a motion by Sorensen, second by Kirchner, the Board approved the purchase of a 2024 Police Package Dodge Durango in the amount of \$55,000.00. Ayes: All.

On a motion by Sorensen, second by Sauer, the Board approved the County Recorder's Report of Fee's collected for the quarter ending December 31, 2025, in the amount of \$59,828.83. Ayes: All.

On a motion by Sorensen, second by Kirchner, the Board approved the Muscatine County Sheriff's Office – Civil Department's Report of Fees Collected for the quarter ending December 31, 2025, in the amount of \$34,352.94. Ayes: All.

On a motion by Sauer, second by Sorensen, the Board approved the County Auditor's Report of Fee's collected for the quarter ending December 31, 2025, in the amount of \$18,926.77. Ayes: All.

On a motion by Kirchner, second by Sorensen, the Board approved the County Treasurer's Quarterly Report of Fee's collected for the quarter ending December 31, 2025, in the amount of \$678,294.55. Ayes: All.

Oa motion by Sorensen, second by Sauer, the Board approved the minutes of the January 5, 2026, regular meeting. Ayes: All.

Correspondence:

Sauer received a call from a resident with a road culvert issue. Sauer will contact County Engineer, Bryan Horesowsky.

Committee & Meeting Reports:

Chick and Sorensen attended the MUSCO Sports Center ribbon cutting ceremony on January 8, 2026. Sorensen stated Mather spoke at the ceremony.

Kirchner announced the Muscatine County Blue Ribbon Fundraiser is scheduled for January 17, 2026 at the new Kent Center Event Space. Tickets are available from Fair Board members and the Fair Board office.

Sorensen attended an Emergency Management meeting on January 7, 2026.

On a motion by Sorensen, second by Kirchner the Board tabled possible action authorizing the Chair to sign an Indemnity Agreement with Rock Valley Physical Therapy. Ayes: All.

GIS Manager Mark Yerington reviewed the FY26/27 MAGIC budget request stating conversion and upgrades were done in 2025. The projected upgrades for the upcoming fiscal year are for MAGIC control network to a new coordinate system and to convert the parcel fabric to Arc GIS Pro system. The other areas of the budget have no significant changes.

Medical Examiner, Tom Summitt reviewed the FY26/27 budget requests stating no significant changes. Summitt noted a budget request for a 3% increase for Medical Examiners Investigators.

County Auditor Tibe Vander Linden stated the FY26/27 budget has no significant changes. The upcoming fiscal year will have only one known election, the General Gubernatorial Election to be held November 3, 2026.

County Treasurer Amy Zybarth reviewed the FY26/27 budget requests stating an increase in postage and mailing due to rising postage rates. Zybarth reviewed the predicted revenue increase for Motor Vehicle Use Tax due to recent legislative changes.

County Recorder Sarah Heart stated the FY26/27 budget has no significant changes

County Conservation Director Katie Hammond reviewed the FY26/27 budget requests for the Deep Lakes Park custodial supplies, electricity, water sampling and water conditioning items. Sorensen recommended tracking the annual cost and revenue associated with the Deep Lakes Park and campground going forward. Hammond stated there will be no staff changes. Hammond reviewed the REAP budget stating they are receiving quotes for new restroom facilities at Salisbury Park boat landing campground and another at the Chicken Creek area. Hammond stated the REAP salary increase is for half of two salary items for the intern naturalist and for Dave Shuyler's animal care salary (half from General Basic budget and half from REAP). Hammond reviewed the Conservation Reserve account stating the Capital Project amount will remain the same and the Deep Lakes Park maintenance building project line item remains the same as last year, with additional funds for the project from the county's Capital Project funds. Hammond stated the Equipment Reserve item is for a proposed side by side vehicle with a blade for snow removal at Deep Lakes Park. Hammond stated an increase in revenue for camping fees, firewood sales, program fees, canoe rentals, shelter and lodge fees.

Community Services Director Jessica Bopes reviewed the FY26/27 General Assistance/Veteran's Affairs budget. Bopes stated the Professional Fees for the Mental Health Advocate is a place holder amount as the ASO is providing the advocate but if the ASO does not pay, the county is responsible. Bopes requested a replacement vehicle as they currently have a 2014 Chevy Malibu and stated a SUV would be more suitable in size. The Board held discussion on the current fleet of vehicles and stated a review of the fleet to see if departments could share a vehicle is in order. Bopes reviewed the increase in rent payment assistance and stated the MCSA Rent Payment shows a large increase, however this is just a reallocated amount of moving the MCSA Shelter Case Coordinator amount to this line item. Bopes stated an increase for software as the CSN System (previously paid for by the Region) has been set up which will allow all information in one place. Information Services Director Bill Riley reviewed the FY26/27. Riley reviewed the telephone

service, metro area network and service agreements. Riley stated the additional staff member has been a positive addition.

County Engineer Bryan Horesowsky reviewed the FY26/27 budget requests for secondary roads revenue, road use taxes and local option sales tax. Horesowsky reviewed construction expenses, noting a decrease due to Stewart Road project no longer being part of the budget. Horesowsky stated there is an increase in engineering services due to stream bed credits when replacing bridges and box culverts. The Board held discussion to investigate a consultanting service regarding stream bed credits. Bridge inspections have decreased due to a smaller number of inspections this year. Horesowsky reviewed the roads and roadside maintenance budgets. The Board questioned if the Safety Action Plan should be reviewed. Horesowsky stated the Plan and DOT safety concerns (where the systems meet) will be reviewed with Sheriff Quinn Riess as he has records of possible unsafe intersections. Chick questioned if flashing stop signs were approved or needs reviewed. Sorensen stated a review can be conducted during the Safety Action Plan review. Horesowsky reviewed the Capital Expenditure requests with some equipment items being carryover items from this fiscal year. Horesowsky stated that corrugated pipe cost has an increase due to low inventory and increased material cost and noted the real estate item for the engineering and zoning building is a carryover budget item with a 1% increase.

The meeting adjourned at 11:13 A.M.

ATTEST:

Tibe Vander Linden
County Auditor

Danny Chick, Chairperson
Board of Supervisors

Muscatine County Board of Supervisors
Monday, January 13, 2026

The Muscatine County Board of Supervisors met in regular session at 9:00 A.M. with Chick, Kirchner, Mather, Sorensen and Sauer present. Chairperson Chick presiding.

On a motion by Sorensen, second by Mather, the agenda was approved as presented. Ayes: All.

Unity Public Health Director Jen Craft reviewed the FY26/27 budget request presenting a slide show of the past year's services the department provided. Craft provided a budget request justification report showing a county cost per citizen for essential services of \$7.45.

County Attorney Korie Talkington reviewed the FY26/27 budget stating she has not worked with the budget previously and is only eight days into the appointment as County Attorney.

Talkington stated a MOU was signed with the City of Muscatine for the City Prosecutor Reimbursement to increase the amount from \$40,000 (this rate has been held for approximately 10 years) to \$50,000. Talkington stated the Fine Collection program runs well. Talkington stated the budget (per former County Attorney Jim Barry) requests another Assistant County Attorney. Talkington stated it appears another Assistant is needed, however a recent meeting with two judges has led to discussing the possibility of changing court schedules, which may help the office manage their time more efficiently. Talkington recommended a change to forfeitures to no longer wave the county portion of the fees.

County Sheriff Quinn Riess reviewed the FY26/27 Patrol budget stating a decrease to the fuel and motor vehicles. Riess stated the new equipment budget is increased as tasers are due for replacement. Other increases include education and training, maintenance agreement (generator), guns/ammo and motor vehicle set up. Riess reviewed the Jail budget stating there are decreases for fuel and telephone interpreters and increases for postage/ mailing, professional fees-training (real time updates), utilities and vehicle maintenance. Riess reviewed the medical contract for the nursing staff. Riess stated the kitchen food and provisions increase is due to federal guideline changes. Riess stated a possible increase to the jail per diem is under review with Jail Administrator Matt McCleary.

County Development Director Eric Furnas reviewed the FY26/27 Zoning and Environmental Services budget. Furnas stated the increase for salaries is due to a potential grade and step increase for an employee taking the test for E2 Electrical Inspector license required for commercial inspections. Furnas reviewed increases in equipment (GPS update) and ordinance revisions due to state code minimum revisions.

Furnas reviewed the FY26/27 General Services budget stating an increase for education and training for lock system training for one employee to attend. Furnas stated the Community Services building heat pump replacement (two pumps) are budgeted for.

Budget & Administrative Services Director Kala Naber reviewed FY26/27 Board/Administration budget stating a decrease in salaries due to change in staff and an increase in televised fees due to the new contract. The Board held discussion on adding additional funding for televised meetings for public hearings and special meetings. Naber stated an additional \$4,000 can be included in the budget to allow for the additional televised meeting costs.

Naber reviewed the FY67/27 Court Services budget stating there is an increase in juvenile detention due to the contract with Scott County to hold one bed for detainees.

Naber reviewed the FY26/27 DHS budget with no change in expenditures and revenues.

Naber reviewed the FY26/27 Non-Departmental budget stating an increase for MUSCOM, Emergency Management and liability insurance. Naber reviewed the ARPA Recovery Funds, LG Abatement (Opioid Settlement Administration) budget and Debt Service payments.

The Board recessed at 12:01 P.M. and reconvened at 1:00 P.M.

On a motion by Sorensen, second by Mather, the Board approved the revised class specifications and grade assignments, due to AFSCME union decertification, effective July 1, 2026. Ayes: All.

The Board held discussion with Budget & Administrative Services Director Kala Naber, Sheriff Quinn Riess and Jail Administrator Matt McCleary regarding revised class specifications and grade assignments for AFSCME. Riess recommended step changes for a food service worker, jail receptionist and jail records clerk. The Board consensus was to accept the recommendations as presented and to act on the revisions for grade assignments and steps.

On a motion by Sauer, second by Sorensen, the Board approved placement of current employees into the revised grade assignments and steps with changes, due to the decertification of the AFSCME union, effective July 1, 2026. Ayes: All.

- Administrative Assistant – Jail (Grade 10)
Tara Hogan – Step 16
- Commissary Manager (Grade 9)
Tracie Williams – Step 5
- Commissary/Food Service Worker (Grade 6)
(LeAnne Daufeldt – Step 1)
- Food Service Worker (Grade 6)
(Sara Carmichael – Step 3) (Tracy Frymoyer – Step 12) (Stephanie Honts – Step 3)
- Food Service Worker II (Grade 7)
(Michelle Leopard – Step 12)
- Jail Medical Records Clerk (Grade 8)
(Part Time Position – Vacant with no intention to fill at this time)

- Jail Receptionist (Grade 8)
(Sonya Sturms – Step 8)
- Jail Records Clerk (Grade 8)
(Brenda Eagle – Step 8)

Riess requested a salary change for a current Lieutenant to be changed from Grade 14, Step 2 to Grade 14, Step 9, due to the salary study changes creating the salary for a current Sargeant at Grade 12, Step 18, who is now paid a higher salary than the Lieutenant (at Grade 14, Step 2). The Board consensus was to add this recommendation to the agenda for Monday, January 19, 2026, for discussion and possible action.

Naber held discussion with the Board regarding placement of current employees into the revised class specifications listed below, with no change to current grade assignments or steps, effective today. The proposed change will not alter current salaries or grade/step assignments. The job descriptions have been updated to the current positions listed.

On a motion by Sorensen, second by Mather, the Board approved placement of current employees into the revised class specifications listed below, with no change to current grade assignments or steps, effective today January 13, 2026. Ayes: All.

- Administration & Finance Director (Grade 18)
(Kala Naber – Step 6)
- County Development Director (Grade 18)
(Eric Furnas – Step 19)

Naber held discussion with the Board regarding the Levee Projects remaining funds. The Board consensus was to repurpose the funds towards other capital projects.

Furnas reviewed the Capital Project Plan.

Naber reviewed the ARPA Recovery funds with a possible overage that can be repurposed with no restrictions. Naber reviewed the FY26/27 valuation increase and levy estimates.

The meeting adjourned at 2:56 P.M.

ATTEST:

Tibe Vander Linden
County Auditor

Danny Chick, Chairperson
Board of Supervisors



City of Muscatine

LIBRARY BOARD OF TRUSTEES

Wednesday, November 19, 2025

The Library Board of Trustees meets on the 3rd Wednesday of each month at 4:30 p.m. in the Library Conference Room

AGENDA

1. CALL TO ORDER
2. APPROVAL OF AGENDA
3. APPROVAL OF MINUTES
4. RATIFY BILLS FOR PAYMENT
5. RECEIVE COMMUNICATION
6. COMMUNICATIONS - CITIZENS
7. STAFF LIAISON
8. FRIENDS' REPORT
9. DIRECTORS' REPORT

10. **BOARD TRAINING**

11. **OLD BUSINESS**

12. **NEW BUSINESS**

- A. Request to Approve Cancellation of December 2025 Board Meeting
- B. Request to Approve Travel, Lodging, and Registration Costs for PLA for Molly Garrett and Emerson Taylor in the Amount of \$3,911.12

13. **ADJOURNMENT**

14. **NEXT MEETING**

- A. January 21, 2026

Muscatine County Board of Supervisors
Monday, January 19, 2026

The Muscatine County Board of Supervisors met in regular session at 9:00 A.M. with Chick, Kirchner, Sauer and Sorensen present. Mather was absent. Chairperson Chick presiding.

On a motion by Sorensen, second by Sauer, the agenda was approved as presented. Ayes: All.

On a motion by Sauer, second by Sorensen, the Board approved claims dated January 19, 2026, in the amount of \$578,925.98. Ayes: All.

County Development Director Eric Furnas reviewed a Special Use Permit for a Rural Residence granted by the Muscatine County Board of Adjustment on January 9, 2026. Case #25-01-01 was a Reconsider Case with an application filed by K & R LLC, Record Owner, to allow the construction of a rural residence on the parcel. The affected property is in Sweetland Township, in parts of the SW ¼ of Section 4-T77N-R1W, Parcel #09-04-300-006, containing approximately 6.84 acres and is zoned A-1 Agricultural District. The Board of Adjustment acknowledged that the CSR2 of the ag land was considerably higher than what they would normally consider, but that the relatively small parcel size already limited the farmland value. They also acknowledged the proposed dwelling would be less than 750 feet from the closest dwelling but noted that there is already significant residential development across Sweetland Road that gave the area a residential feel. The Board of Adjustment approved the Special Use Permit 4-1. Sauer questioned that the parcel was reconsidered due to the high CSR and asked what the highest CSR rating number is when considering a special use permit application. Furnas stated the ordinance states anything over a rating of 55 should not be allowed. Sauer asked what the rating is for the parcel. Furnas stated it is rated at 82 or 83. Sauer asked if the rating was actually over 50% higher than allowed. Furnas stated that is correct. Sauer questioned the value of the farmland statement, the 750 feet separation and the significant residential development across Sweetland Road. Sauer stated there are only two houses across Sweetland Road that have been there for 100 years. Sauer stated that if they are speaking of 170th Street where Sweetland Acres is (where the sale barn used to be), there is significant residential development on 170th Street. Sauer stated he doesn't understand the logic with this special use permit. Sorensen stated this is the second time this corner has come up for discussion in the past several years. Sorensen stated when Sweetland Mill area was looking at making some changes they had significant conflicts that did not allow them to continue their operations due to the residential area behind them. Sorensen stated that issuing special use permits can become a concern when a property is transferred to a new owner in the future. Sauer stated this approval goes against all the guidelines that have been set forth.

On a motion by Sorensen, second by Kirchner, the Board approved Resolution #01-19-26-01 Approval of the Combined Preliminary and Final Plat of Phillips Acres Subdivision. Roll call vote: Ayes: Sorensen, Kirchner, Chick. Sauer abstained from voting. Motion passed 3-0.

On a motion by Sorensen, second by Kirchner, the Board approved the minutes of

January 12, 2026, regular meeting and the minutes of January 13, 2026, special meeting.

Ayes: All

Correspondence.

No correspondence was reported.

Committee Reports.

Sorensen attended a meeting with local leaders on January 15, 2026, regarding a 15 bed MCSA facility is located at the corner of 5th Street and Orange Street. The facility is scheduled to open in February or March 2026.

Kirchner attended the Muscatine County Fair Blue Ribbon Fundraiser at the new Kent Event Center on January 17, 2026.

Kirchner attended the Muscatine County Fair Board meeting on January 15, 2026.

Sauer attended the Muscatine County Board of Health meeting on January 14, 2026.

On a motion by Sorensen, second by Kirchner, the Board approved placement of Corrections Lieutenant Tye Hardman into Grade 14 Step 9, effective January 24, 2026.

Ayes: All.

Conservation Director Katie Hammond stated the Deep Lakes Campground Ribbon Cutting Ceremony date will be set at tonight's Conservation Board Public Hearing. The proposed date is February 2, 2026, at 11:00 A.M. The on-line reservation for the campground is scheduled to go live after the ribbon cutting.

County Engineer Bryan Horesowsky stated the F70 Mosquito Creek bridge contract documents have been received and are in order. Horesowsky stated he will be meeting with the contractor.

County Development Director Eric Furnas spoke with Terry Martin, Trustee for Drainage District #13 regarding a proposed project at Whiskey Creek/Whiskey Hollow for a sediment basin. Furnas will draft a general support letter with the proposed project concept for the Board. Sorensen recommended Drainage District #13 reach out to Bi-State Regional Planning Commission for grant opportunities.

The meeting was adjourned at 9:16 A.M.

ATTEST:

Tibe Vander Linden
County Auditor

Danny Chick, Chairperson
Board of Supervisors

Muscatine County Board of Supervisors
Tuesday, January 20, 2026

The Muscatine County Board of Supervisors met in special session at 9:00 A.M. with Chick, Kirchner, Mather, Sauer and Sorensen present. Chairperson Chick presiding.

On a motion by Sorensen, second by Sauer, the agenda was approved as presented. Ayes: All.

The Board reviewed FY26/27 funding requests from outside agencies as follows:

| | | |
|---|--|-----------------------------|
| West Liberty Library – Allie Paarsmith | | |
| FY25/26 Allocation \$17,000 | | FY26/27 Request \$39,260.58 |
| Musser Public Library – Robert Fiedler | | |
| FY25/26 Allocation \$134,112 | | FY26/27 Request \$138,135 |
| Muscatine Legal Services –Daniel Hartin and Cindy Sorenson | | |
| FY25/26 Allocation \$45,000 | | FY26/27 Request \$55,000 |
| Wilton Library – Kristi Hager | | |
| FY25/26 Allocation \$17,000 | | FY26/27 Request \$25,000 |
| River Bend Transit – Sherli Childers | | |
| FY25/26 Allocation \$7,000 | | FY26/27 Request \$7,000 |
| Greater Muscatine Chamber of Commerce and Industry – Brad Bark | | |
| FY25/26 Allocation \$15,000 | | FY26/27 Request \$15,000 |
| Grow Quad Cities (QC Chamber) –Julie Forsythe | | |
| FY25/26 Allocation \$5,000 | | FY26/27 Request \$5,000 |
| Wilton Chamber & Development Alliance – Becky Allgood, Rhonda Brown and Catherine Brown | | |
| FY25/26 Allocation \$10,000 | | FY26/27 Request \$10,000 |
| WELEAD (West Liberty Economic Area Development) – Philip Wiese | | |
| FY25/26 Allocation \$10,000 | | FY26/27 Request \$10,000 |
| Muscatine County Fair Board – Kelsey Meyers | | |
| FY25/26 Allocation \$30,000 | | FY26/27 Request \$40,000 |
| Community Foundation – Grant Writer – Erin Gruban and Charla Schafer | | |
| FY25/26 Allocation \$27,500 | | FY26/27 Request \$28,500 |
| Lower Cedar Watershed Management Authority – Eric Furnas | | |
| FY25/26 Allocation -N/A | | FY26/27 Request \$25,000 |

The Board reviewed the FY26/27 budget requests from outside agencies that were presented at today's meeting.

The Board canvassed the Drainage District #1 Election held on January 17, 2026. Results were as follows: For the office of Trustee for the three-year term beginning January 24, 2026 – 5 votes were cast. Travis Parry received 5 votes. Travis Parry was elected.

The Board canvassed the Drainage District #4 Election held on January 17, 2026. Results were as follows: For the office of Trustee for the three-year term beginning January 24, 2026 – 3 votes were cast. Russ Vanacker received 3 votes. Russ Vanacker was elected.

The Board canvassed the Drainage District #5 Election held on January 17, 2026. Results were as follows: For the office of Trustee for the three-year term beginning January 24, 2026 – 3 votes were cast. Mike Meyers received 3 votes. Mike Meyers was elected.

The Board canvassed the Drainage District #9 Election held on January 17, 2026. Results were as follows: For the office of Trustee for the three-year term beginning January 24, 2026 – 3 votes were cast. Don Feldman received 3 votes. Don Feldman was elected.

The Board canvassed the Drainage District #10 Election held on January 17, 2026. Results were as follows: For the office of Trustee for the three-year term beginning January 24, 2026 – 6 votes were cast. Gary Hepker received 6 votes. Gary Hepker was elected.

The Board canvassed the Muscatine-Louisa Drainage District #13 Third District Election held on January 17, 2026. Results were as follows: For the office of Trustee for the three-year term beginning January 24, 2026 – 3799 votes were cast. Terry Martin received 3799 votes. Terry Martin was elected.

The Board canvassed the Muscatine-Louisa Drainage District #17 Third District Election held on January 17, 2026. Results were as follows: For the office of Trustee for the three-year term beginning January 24, 2026 – 3 votes were cast. Louis Broders received 3 votes. Louis Broders was elected.

The Board canvassed the Muscatine-Louisa Island Levee - First District Election held on January 17, 2026. Results were as follows: For the office of Trustee for the three-year term beginning January 24, 2026 – 8 votes were cast. Keith Bartenhagen received 8 votes. Keith Bartenhagen was elected.

The meeting was adjourned at 1:00 P.M.

ATTEST:

Tibe Vander Linden
County Auditor

Danny Chick, Chairperson
Board of Supervisors

City of Muscatine
Summary of Fund Transactions
Fiscal Year to Date through November, 2025

| | <u>Beginning Balance 7/1/2025</u> | <u>Revenues</u> | <u>Expenditures</u> | <u>Ending Balance 11/30/2025</u> | <u>Reserve for Encumbrances</u> | <u>Unobligated Ending Balance 11/30/2025</u> |
|--|---|------------------------|------------------------|--|-------------------------------------|--|
| General Fund | \$ 5,541,179.72 | \$ 10,233,891.82 | \$ 11,005,674.31 | \$ 4,769,397.23 | \$ 818,898.17 | \$ 3,950,499.06 |
| Debt Service Fund | | | | | | |
| General Obligation | \$ 105,477.52 | \$ 1,302,489.28 | \$ 270,287.50 | \$ 1,137,679.30 | \$ - | \$ 1,137,679.30 |
| Trust and Agency | | | | | | |
| Park Trusts: | | | | | | |
| J Donald McPike Trust - Weed Park Rose Garden | \$ 348,305.62 | \$ - | \$ - | \$ 348,305.62 | \$ - | \$ 348,305.62 |
| J Donald McPike Trust - Cemetery / Other Parks | 87,076.40 | - | - | 87,076.40 | - | 87,076.40 |
| Jerry Lange Trust - Community Holiday Decorations | 30,104.89 | - | - | 30,104.89 | - | 30,104.89 |
| Cemetery Trust: | | | | | | |
| Perpetual Care | 927,606.06 | 2,470.00 | - | 930,076.06 | - | 930,076.06 |
| Perpetual Care Interest | - | 1,981.93 | 1,981.93 | - | - | - |
| Robert Jackson Trust | 6,636.73 | - | - | 6,636.73 | - | 6,636.73 |
| Anna Strohmeier Trust | 1,169.75 | - | - | 1,169.75 | - | 1,169.75 |
| Esther Rieke Trust | 1,366.34 | - | - | 1,366.34 | - | 1,366.34 |
| Ethel Fulliam Trust | 3,267.79 | - | - | 3,267.79 | - | 3,267.79 |
| Minnie Beyer Trust | 10,269.52 | - | - | 10,269.52 | - | 10,269.52 |
| Laura Musser Atkins Flower Trust | 4,805.68 | - | - | 4,805.68 | - | 4,805.68 |
| Bert Benham Trust | 2,096.12 | - | - | 2,096.12 | - | 2,096.12 |
| Henry Friedli Trust | 17,180.66 | - | - | 17,180.66 | - | 17,180.66 |
| Kathryn M. Huttig Trust | 7,499.14 | - | - | 7,499.14 | - | 7,499.14 |
| Kathryn M. Huttig Mausoleum Trust | 1,091.34 | - | - | 1,091.34 | - | 1,091.34 |
| Harvey Long Trust | 1,484.85 | - | - | 1,484.85 | - | 1,484.85 |
| Linda Musser Special Flower Trust | 717.44 | - | - | 717.44 | - | 717.44 |
| George Titus Trust | 55.81 | - | - | 55.81 | - | 55.81 |
| Library Trust: | | | | | | |
| Gift and Memorial Trust | 169,386.93 | 12,420.93 | 9,123.78 | 172,684.08 | - | 172,684.08 |
| Art Center Trusts: | | | | | | |
| General Donations Trust | 51,507.31 | 1,487.11 | 2,389.11 | 50,605.31 | - | 50,605.31 |
| Brad Burns Trust | 143,830.75 | - | - | 143,830.75 | - | 143,830.75 |
| McWhirter-Gilmore Trust | 119,883.65 | - | - | 119,883.65 | - | 119,883.65 |
| Alice Schaeffer Trust | 53,766.74 | - | - | 53,766.74 | - | 53,766.74 |
| Fund Total | \$ 1,989,109.52 | \$ 18,359.97 | \$ 13,494.82 | \$ 1,993,974.67 | \$ - | \$ 1,993,974.67 |
| Capital Projects Funds | \$ 5,198,752.58 | \$ 641,413.48 | \$ 3,320,084.94 | \$ 2,520,081.12 | \$ - | \$ 2,520,081.12 |
| Enterprise Funds: | | | | | | |
| Transit: | | | | | | |
| Operations | \$ 535,651.82 | \$ 238,403.27 | \$ 892,682.06 | \$ (118,626.97) | \$ 226,250.46 | \$ (344,877.43) |
| Transit Vehicle Wash Bay | 50,175.18 | - | 29,237.36 | 20,937.82 | - | 20,937.82 |
| Subtotal | <u>\$ 585,827.00</u> | <u>\$ 238,403.27</u> | <u>\$ 921,919.42</u> | <u>\$ (97,689.15)</u> | <u>\$ 226,250.46</u> | <u>\$ (323,939.61)</u> |
| Parking System | 97,625.97 | 86,453.58 | 95,646.78 | 88,432.77 | 9,488.50 | 78,944.27 |
| Golf Course | 429,500.59 | 555,330.10 | 480,816.40 | 504,014.29 | 16,037.15 | 487,977.14 |
| Boat Harbor Operations | 0.00 | 1,422.00 | 10,460.59 | (9,038.59) | - | (9,038.59) |
| Marina Operations | (4,331.18) | 4,235.99 | 2,454.93 | (2,550.12) | - | (2,550.12) |
| Solid Waste Management: | | | | | | |
| Refuse Collection | \$ 291,708.29 | \$ 890,440.64 | \$ 900,301.02 | \$ 281,847.91 | \$ 4,005.22 | \$ 277,842.69 |
| Landfill Operations | 2,703,488.96 | 480,278.45 | 307,230.55 | 2,876,536.86 | 5,155.80 | 2,871,381.06 |
| Landfill Surcharge - Part I | - | - | - | - | - | - |
| Landfill Surcharge - Part II | - | - | - | - | - | - |
| Landfill Closure Reserve | 2,118,379.00 | - | - | 2,118,379.00 | - | 2,118,379.00 |
| Landfill Post-Closure Reserve | 1,368,138.00 | - | - | 1,368,138.00 | - | 1,368,138.00 |
| Transfer Station Operations | 251,590.78 | 891,959.22 | 877,444.99 | 266,105.01 | 2,610.99 | 263,494.02 |
| Transfer Station Fire Suppression/Floor/Other Projects | 163,924.09 | - | - | 163,924.09 | - | 163,924.09 |
| Transfer Station Closure Reserve | 33,825.00 | - | - | 33,825.00 | - | 33,825.00 |
| Subtotal | <u>\$ 6,931,054.12</u> | <u>\$ 2,262,678.31</u> | <u>\$ 2,084,976.56</u> | <u>\$ 7,108,755.87</u> | <u>\$ 11,772.01</u> | <u>\$ 7,096,983.86</u> |

City of Muscatine
Summary of Fund Transactions
Fiscal Year to Date through November, 2025

| | Beginning | | Ending | | Unobligated | |
|--|-------------------------|-------------------------|-------------------------|-------------------------|------------------------|-------------------------|
| Water Pollution Control: | | | | | | |
| Operations | \$ 2,258,472.83 | \$ 1,846,413.56 | \$ 2,706,980.96 | \$ 1,397,905.43 | \$ 295,449.65 | \$ 1,102,455.78 |
| Collection and Drainage (Inc. Storm Water) | 1,105,456.37 | 728,941.89 | 763,631.49 | 1,070,766.77 | 593,019.88 | 477,746.89 |
| Sewer Systems Extension & Improvement Reserve | 2,429,818.04 | 145,833.35 | - | 2,575,651.39 | - | 2,575,651.39 |
| Water Pollution Control Replacement Reserve | 2,388,386.40 | 166,666.65 | - | 2,555,053.05 | - | 2,555,053.05 |
| Sewer Revenue Bond Sinking Fund | 200,484.52 | 408,697.90 | - | 609,182.42 | - | 609,182.42 |
| West Hill Sewer Separation Reserve | 6,442,748.12 | 166,666.70 | - | 6,609,414.82 | - | 6,609,414.82 |
| Project Funds: | | | | | | |
| WPCP/Lift Station Electric Upgrade Project | (523,052.43) | - | 112,494.76 | (635,547.19) | - | (635,547.19) |
| WPCP Houser Lift Station Upgrades | - | - | 197,822.00 | (197,822.00) | - | (197,822.00) |
| WPCP Lift Station HVACProject | - | - | - | - | - | - |
| West Hill Sewer - Papoose Pump Station Project | - | - | 69,189.71 | (69,189.71) | - | (69,189.71) |
| West Hill Sewer Separation | (852,710.99) | 3,142,778.39 | 3,745,344.95 | (1,455,277.55) | - | (1,455,277.55) |
| Papoose Sewer Redundant Line | - | - | - | - | - | - |
| Subtotal | \$ 13,449,602.86 | \$ 6,605,998.44 | \$ 7,595,463.87 | \$ 12,460,137.43 | \$ 888,469.53 | \$ 11,571,667.90 |
| Airport: | | | | | | |
| Operations | \$ (0.00) | \$ 78,661.88 | \$ 56,805.25 | \$ 21,856.63 | \$ - | \$ 21,856.63 |
| Airport Fuel System Upgrade | 10,213.09 | - | 191,050.94 | (180,837.85) | - | (180,837.85) |
| Airport Snow Removal Equipment | (2,180.91) | 4,759.50 | 5,444.50 | (2,865.91) | - | (2,865.91) |
| Airport Lighting Improvements (PAPI, REIL) | 33,880.10 | 342,251.75 | 392,358.32 | (16,226.47) | - | (16,226.47) |
| Airport Taxilane Project | (13.68) | - | 241,652.22 | (241,665.90) | - | (241,665.90) |
| Subtotal | \$ 41,898.60 | \$ 425,673.13 | \$ 887,311.23 | \$ (419,739.50) | \$ - | \$ (419,739.50) |
| Ambulance: | | | | | | |
| Operations | \$ 466,228.57 | \$ 138,043.91 | \$ 673,087.07 | \$ (68,814.59) | \$ 10,853.84 | \$ (79,668.43) |
| Equipment Purchases (Bond Funded) | 295,143.89 | - | 281,594.00 | 13,549.89 | - | 13,549.89 |
| Subtotal | \$ 761,372.46 | \$ 138,043.91 | \$ 954,681.07 | \$ (55,264.70) | \$ 10,853.84 | \$ (66,118.54) |
| Convention and Visitors Bureau | \$ - | \$ - | \$ 67,500.00 | \$ (67,500.00) | \$ - | \$ (67,500.00) |
| Soccer Event Fund | \$ - | \$ - | \$ - | \$ - | \$ - | \$ - |
| Fund Total | \$ 22,292,550.42 | \$ 10,318,238.73 | \$ 13,101,230.85 | \$ 19,509,558.30 | \$ 1,162,871.49 | \$ 18,346,686.81 |
| Internal Service Funds | | | | | | |
| Equipment Services Operations | \$ (248,307.54) | \$ 519,830.66 | \$ 433,561.52 | \$ (162,038.40) | \$ 78,485.04 | \$ (240,523.44) |
| Central Office Supplies | (2,418.58) | 749.29 | 287.70 | (1,956.99) | - | (1,956.99) |
| Health Insurance Fund | 3,767,177.93 | 1,928,989.43 | 1,627,104.50 | 4,069,062.86 | - | 4,069,062.86 |
| Dental Insurance Fund | 119,891.05 | 72,306.25 | 38,268.21 | 153,929.09 | - | 153,929.09 |
| Payroll Clearing Fund | - | 33,669.05 | 34,530.73 | (861.68) | - | (861.68) |
| Miscellaneous Clearing Fund | (0.00) | 106,120.69 | 1,022,279.76 | (916,159.07) | - | (916,159.07) |
| Interest Clearing - General Investments | - | 353,676.95 | - | 353,676.95 | - | 353,676.95 |
| Housing Revolving Fund | (0.00) | 267,863.91 | 329,398.86 | (61,534.95) | - | (61,534.95) |
| Fund Total | \$ 3,636,342.86 | \$ 3,283,206.23 | \$ 3,485,431.28 | \$ 3,434,117.81 | \$ 78,485.04 | \$ 3,355,632.77 |

City of Muscatine
Summary of Fund Transactions
Fiscal Year to Date through November, 2025

| | Beginning | | | Ending | | | Unobligated |
|---|-------------------------|-------------------------|-------------------------|-------------------------|------------------------|-------------------------|-------------|
| Special Revenue Funds | | | | | | | |
| Community Block Grant Fund (Prior Year Grants) | \$ 35,094.71 | \$ - | \$ - | \$ 35,094.71 | \$ - | \$ 35,094.71 | |
| CDBG - Neighborhood Grant (6th & Mulberry) (8142) | (136,212.89) | 142,617.00 | 285,902.43 | (279,498.32) | 252.00 | (279,750.32) | |
| IEDA - Downtown Housing | (80,000.00) | 80,000.00 | - | - | - | - | |
| CDBG - Downtown Revitalization Grant (8144) | (137,243.10) | 111,118.00 | 34,988.26 | (61,113.36) | - | (61,113.36) | |
| Downtown Historic Revitalization Grant (8146) | (3,525.92) | - | 29,956.14 | (33,482.06) | - | (33,482.06) | |
| Nuisance & Abandoned Property Grant (8147) | (98,509.00) | - | 5,000.00 | (103,509.00) | - | (103,509.00) | |
| Lead Hazard Reduction Grant (8148) | - | 24,867.49 | 66,586.91 | (41,719.42) | 120.00 | (41,839.42) | |
| CDBG - CV Grant (MCSA) (8149) | - | - | 11,470.57 | (11,470.57) | - | (11,470.57) | |
| Home Ownership Program | 29,840.25 | 21,592.52 | 47,827.43 | 3,605.34 | - | 3,605.34 | |
| Sunset Park Children's Education Program | 7,779.42 | - | - | 7,779.42 | - | 7,779.42 | |
| Public Housing Legal Settlement | 152,213.69 | - | - | 152,213.69 | - | 152,213.69 | |
| Road Use Tax Fund | 1,884,029.61 | 915,181.91 | 1,340,472.11 | 1,458,739.41 | - | 1,458,739.41 | |
| Employee Benefit Fund | 211,300.25 | 2,802,831.67 | 2,169,921.84 | 844,210.08 | - | 844,210.08 | |
| Emergency Tax Levy/Emergency Fund | 729,658.53 | - | - | 729,658.53 | - | 729,658.53 | |
| American Rescue Plan Act Fund | 98,394.69 | - | 76,197.04 | 22,197.65 | - | 22,197.65 | |
| Equipment Replacement Fund | 130,133.77 | 3,000.00 | 293,445.43 | (160,311.66) | 109,962.00 | (270,273.66) | |
| Computer Replacement Fund | 104,275.96 | 12,500.00 | 1,778.57 | 114,997.39 | 3,640.02 | 111,357.37 | |
| Library Computer Replacement Sub-Fund | 45,969.00 | - | 7,979.54 | 37,989.46 | 3,009.30 | 34,980.16 | |
| Local Option Sales Tax Fund | 4,653,943.61 | 997,477.27 | - | 5,651,420.88 | - | 5,651,420.88 | |
| Local Option Pavement Management Subfund | 662,383.11 | - | - | 662,383.11 | - | 662,383.11 | |
| Downtown Tax Increment Fund | 18,371.27 | 133,655.61 | - | 152,026.88 | - | 152,026.88 | |
| Southend Tax Increment Fund | 426,324.03 | 809,270.91 | 186,080.38 | 1,049,514.56 | - | 1,049,514.56 | |
| Cedar Development Tax Increment Fund | 74,591.99 | - | - | 74,591.99 | - | 74,591.99 | |
| Highway 38 Northeast Tax Increment Fund | 29,442.22 | 5,101.14 | 5,106.97 | 29,436.39 | - | 29,436.39 | |
| Fridley Tax Increment Fund | 75,558.72 | 34,293.72 | 23,700.88 | 86,151.56 | - | 86,151.56 | |
| Riverview Hotel Tax Increment | 37,626.91 | 202,212.98 | 189,961.89 | 49,878.00 | - | 49,878.00 | |
| North University Tax Increment | 29,074.75 | 54,074.65 | 52,688.03 | 30,461.37 | - | 30,461.37 | |
| Northeast Area Tax Increment (WDS) | 27,800.89 | 40,811.25 | 37,230.69 | 31,381.45 | - | 31,381.45 | |
| Arbor Commons Tax Increment | 8,906.60 | 24,423.40 | 13,663.09 | 19,666.91 | - | 19,666.91 | |
| Hershey Building Tax Increment | 7,929.88 | - | - | 7,929.88 | - | 7,929.88 | |
| Oak Park Tax Increment | 12,945.39 | 19,895.76 | 12,951.22 | 19,889.93 | - | 19,889.93 | |
| Steamboat Tax Increment | 5,229.60 | - | 4,671.29 | 558.31 | - | 558.31 | |
| Colorado Lofts Tax Increment | - | 13,004.34 | 13,004.34 | - | - | - | |
| LMI Setaside Fund | 22,653.15 | - | - | 22,653.15 | - | 22,653.15 | |
| Riverview Reinvestment District | - | - | - | - | - | - | |
| Small Business Forgivable Loan Program | 602.78 | - | 123,400.00 | (122,797.22) | - | (122,797.22) | |
| Small Business Forgivable Loan - Code Compliance | - | - | - | - | - | - | |
| Small Business Forgivable Loan - 2nd Street Facades | 27,020.32 | - | - | 27,020.32 | - | 27,020.32 | |
| Fund Total | \$ 9,093,604.19 | \$ 6,447,929.62 | \$ 5,033,985.05 | \$ 10,507,548.76 | \$ 116,983.32 | \$ 10,390,565.44 | |
| Total | \$ 47,857,016.81 | \$ 32,245,529.13 | \$ 36,230,188.75 | \$ 43,872,357.19 | \$ 2,177,238.02 | \$ 41,695,119.17 | |

**City of Muscatine
Operating Departments
Summary of Expenditures
For the Month of November, 2025**

| | Budget | Year-To-Date Expenditures | Encumbrances | Total Expenditures and Encumbrances | Remaining Balance After Encumbrances | Percentage Expended an Encumbranc |
|-----------------------------------|-------------------------|--------------------------------------|---------------------|--|---|--|
| General Government | | | | | | |
| Mayor and Council | \$ 90,300.00 | \$ 68,640.39 | \$ - | \$ 68,640.39 | \$ 21,659.61 | 76.01% |
| Legal Service | 152,500.00 | 23,635.60 | - | 23,635.60 | 128,864.40 | 15.50% |
| City Administrator | 565,700.00 | 250,414.65 | - | 250,414.65 | 315,285.35 | 44.27% |
| Human Resources | 221,600.00 | 104,969.81 | 3,500.00 | 108,469.81 | 113,130.19 | 48.95% |
| Wellness Program | 70,500.00 | 19,456.70 | 1,200.00 | 20,656.70 | 49,843.30 | 29.30% |
| Finance and Records | 916,400.00 | 594,642.88 | 4,430.30 | 599,073.18 | 317,326.82 | 65.37% |
| Computer Operations | 517,700.00 | 249,589.33 | - | 249,589.33 | 268,110.67 | 48.21% |
| Risk Management | 584,000.00 | 59,838.76 | - | 59,838.76 | 524,161.24 | 10.25% |
| Building and Grounds | 810,500.00 | 293,497.79 | 17,718.88 | 311,216.67 | 499,283.33 | 38.40% |
| | | | | - | | |
| Subtotal | <u>\$ 3,929,200.00</u> | <u>\$ 1,664,685.91</u> | <u>\$ 26,849.18</u> | <u>\$ 1,691,535.09</u> | <u>\$ 2,237,664.91</u> | 43.05% |
| Public Safety | | | | | | |
| Police Operations | \$ 6,233,700.00 | \$ 2,719,910.66 | \$ 36,620.73 | \$ 2,756,531.39 | \$ 3,477,168.61 | 44.22% |
| Animal Control | 158,200.00 | 49,083.59 | 369.18 | 49,452.77 | 108,747.23 | 31.26% |
| Fire Operations | 6,174,700.00 | 2,746,268.79 | 13,928.14 | 2,760,196.93 | 3,414,503.07 | 44.70% |
| Subtotal | <u>\$ 12,566,600.00</u> | <u>\$ 5,515,263.04</u> | <u>\$ 50,918.05</u> | <u>\$ 5,566,181.09</u> | <u>\$ 7,000,418.91</u> | 44.29% |
| Culture and Recreation | | | | | | |
| Library | \$ 1,351,900.00 | \$ 518,930.32 | \$ 2,111.82 | \$ 521,042.14 | \$ 830,857.86 | 38.54% |
| Cable Television Operations | - | 2,500.00 | 2,343.82 | 4,843.82 | (4,843.82) | |
| Art Center | 554,900.00 | 252,939.00 | - | 252,939.00 | 301,961.00 | 45.58% |
| Park Administration | 291,300.00 | 126,990.09 | 180.00 | 127,170.09 | 164,129.91 | 43.66% |
| Park Maintenance | 1,006,600.00 | 435,573.59 | 4,448.63 | 440,022.22 | 566,577.78 | 43.71% |
| Kent Stein Park Operations | 287,200.00 | 110,714.66 | 32,485.53 | 143,200.19 | 143,999.81 | 49.86% |
| Soccer Complex Operations | 280,600.00 | 112,216.88 | 15,587.88 | 127,804.76 | 152,795.24 | 45.55% |
| Recreation | 133,500.00 | 53,353.44 | 262.88 | 53,616.32 | 79,883.68 | 40.16% |
| Aquatic Center | 220,100.00 | 108,883.76 | - | 108,883.76 | 111,216.24 | 49.47% |
| Indoor Sports Dome | 409,300.00 | 75,191.53 | 2,821.59 | 78,013.12 | 331,286.88 | 19.06% |
| Cemetery | 232,600.00 | 115,777.74 | 4,684.26 | 120,462.00 | 112,138.00 | 51.79% |
| Subtotal | <u>\$ 4,768,000.00</u> | <u>\$ 1,913,071.01</u> | <u>\$ 64,926.41</u> | <u>\$ 1,977,997.42</u> | <u>\$ 2,790,002.58</u> | 41.48% |
| Health and Social Services | | | | | | |
| Economic Well-Being | \$ 60,000.00 | \$ 30,000.00 | \$ - | \$ 30,000.00 | \$ 30,000.00 | 50.00% |
| Subtotal | <u>\$ 60,000.00</u> | <u>\$ 30,000.00</u> | <u>\$ -</u> | <u>\$ 30,000.00</u> | <u>\$ 30,000.00</u> | 50.00% |

**City of Muscatine
Operating Departments
Summary of Expenditures
For the Month of November, 2025**

| | <u>Budget</u> | <u>Year-To-Date Expenditures</u> | <u>Encumbrances</u> | <u>Total Expenditures and Encumbrances</u> | <u>Remaining Balance After Encumbrances</u> | <u>Percentage Expended an Encumbranc</u> |
|---|-------------------------|--------------------------------------|----------------------|--|---|--|
| Community and Economic Development | | | | | | |
| Community Development | \$ 1,182,800.00 | \$ 454,984.51 | \$ 8,115.77 | \$ 463,100.28 | \$ 719,699.72 | 39.15% |
| Economic Development | 195,000.00 | 26,244.52 | - | 26,244.52 | 168,755.48 | 13.46% |
| Subtotal | <u>\$ 1,377,800.00</u> | <u>\$ 481,229.03</u> | <u>\$ 8,115.77</u> | <u>\$ 489,344.80</u> | <u>\$ 888,455.20</u> | 35.52% |
| Public Works | | | | | | |
| Public Works Administration | \$ 274,400.00 | \$ 104,419.21 | \$ - | \$ 104,419.21 | \$ 169,980.79 | 38.05% |
| Roadway Maintenance | 2,053,000.00 | 812,029.89 | 232,064.05 | 1,044,093.94 | 1,008,906.06 | 50.86% |
| Snow and Ice Control | 653,900.00 | 21,516.67 | 307,148.00 | 328,664.67 | 325,235.33 | 50.26% |
| Street Cleaning | 380,300.00 | 105,538.05 | 125,619.00 | 231,157.05 | 149,142.95 | 60.78% |
| Traffic Control Operations | 215,300.00 | 125,710.38 | 982.80 | 126,693.18 | 88,606.82 | 58.84% |
| Engineering | 459,100.00 | 175,368.82 | 250.00 | 175,618.82 | 283,481.18 | 38.25% |
| Subtotal | <u>\$ 4,036,000.00</u> | <u>\$ 1,344,583.02</u> | <u>\$ 666,063.85</u> | <u>\$ 2,010,646.87</u> | <u>\$ 2,025,353.13</u> | 49.82% |
| Transfers | | | | | | |
| Transit System Subsidy | \$ 78,143.00 | \$ 40,240.46 | \$ - | \$ 40,240.46 | \$ 37,902.54 | 51.50% |
| Equipment Replacement Funding | - | - | - | - | - | #DIV/0! |
| Airport Operations Subsidy | 62,000.00 | - | - | - | 62,000.00 | 0.00% |
| Subtotal | <u>\$ 140,143.00</u> | <u>\$ 40,240.46</u> | <u>\$ -</u> | <u>\$ 40,240.46</u> | <u>\$ 99,902.54</u> | 28.71% |
| Fund Total | <u>\$ 26,877,743.00</u> | <u>\$ 10,989,072.47</u> | <u>\$ 816,873.26</u> | <u>\$ 11,805,945.73</u> | <u>\$ 15,071,797.27</u> | 43.92% |
| Enterprise Funds | | | | | | |
| Transit System | \$ 1,616,300.00 | \$ 499,500.06 | \$ 3,356.46 | \$ 502,856.52 | \$ 1,113,443.48 | 31.11% |
| Parking Operations | 208,900.00 | 95,646.78 | 6,399.50 | 102,046.28 | 106,853.72 | 48.85% |
| Golf Course | 1,168,600.00 | 480,120.40 | 13,478.15 | 493,598.55 | 675,001.45 | 42.24% |
| Boat Harbor Operations | 25,600.00 | 10,460.59 | - | 10,460.59 | 15,139.41 | 40.86% |
| Marina Operations | 10,800.00 | 2,454.93 | - | 2,454.93 | 8,345.07 | 22.73% |
| Airport Operations | 159,900.00 | 56,805.25 | - | 56,805.25 | 103,094.75 | 35.53% |
| Ambulance Operations | 2,639,200.00 | 673,087.07 | 10,853.84 | 683,940.91 | 1,955,259.09 | 25.91% |
| Convention & Visitors Bureau | - | 67,500.00 | - | 67,500.00 | (67,500.00) | #DIV/0! |

**City of Muscatine
Operating Departments
Summary of Expenditures
For the Month of November, 2025**

| | Budget | Year-To-Date Expenditures | Encumbrances | Total Expenditures and Encumbrances | Remaining Balance After Encumbrances | Percentage Expended an Encumbranc |
|-------------------------------------|--------------------------------|--------------------------------------|-------------------------------|--|---|--|
| Solid Waste Management | | | | | | |
| Refuse Collection | \$ 2,504,300.00 | \$ 900,301.02 | \$ 4,005.22 | \$ 904,306.24 | \$ 1,599,993.76 | 36.11% |
| Landfill Operations | 1,372,600.00 | 306,320.53 | 5,155.80 | 311,476.33 | 1,061,123.67 | 22.69% |
| Landfill Surcharge Reserve-Part I | 20,000.00 | - | - | - | 20,000.00 | 0.00% |
| Landfill Surcharge Reserve-Part II | 42,000.00 | - | - | - | 42,000.00 | 0.00% |
| Transfer Station Operations | 2,273,600.00 | 877,444.99 | 2,610.99 | 880,055.98 | 1,393,544.02 | 38.71% |
| Subtotal | <u>\$ 6,212,500.00</u> | <u>\$ 2,084,066.54</u> | <u>\$ 11,772.01</u> | <u>\$ 2,095,838.55</u> | <u>\$ 4,116,661.45</u> | 33.74% |
| Water Pollution Control | | | | | | |
| Administration | \$ 2,627,925.00 | \$ 917,830.61 | \$ 423.14 | \$ 918,253.75 | \$ 1,709,671.25 | 34.94% |
| Plant Operations | 2,017,500.00 | 827,476.73 | 181,058.75 | 1,008,535.48 | 1,008,964.52 | 49.99% |
| Pumping Stations | 573,700.00 | 294,738.54 | 23,931.51 | 318,670.05 | 255,029.95 | 55.55% |
| Laboratory Operations | 589,600.00 | 237,810.41 | 5,254.38 | 243,064.79 | 346,535.21 | 41.23% |
| Biosolids Operations | 490,800.00 | 234,038.20 | 1,562.11 | 235,600.31 | 255,199.69 | 48.00% |
| High Strength Waste Operatons | 375,000.00 | 191,724.47 | 35,903.92 | 227,628.39 | 147,371.61 | 60.70% |
| Subtotal | <u>\$ 6,674,525.00</u> | <u>\$ 2,703,618.96</u> | <u>\$ 248,133.81</u> | <u>\$ 2,951,752.77</u> | <u>\$ 3,722,772.23</u> | 44.22% |
| Collection and Drainage | 2,235,500.00 | 729,637.97 | 593,019.88 | 1,322,657.85 | 912,842.15 | 59.17% |
| Stormwater Operations | 115,300.00 | 33,993.52 | - | 33,993.52 | 81,306.48 | 29.48% |
| Fund Total | <u>\$ 21,067,125.00</u> | <u>\$ 7,436,892.07</u> | <u>\$ 887,013.65</u> | <u>\$ 8,323,905.72</u> | <u>\$ 12,743,219.28</u> | 39.51% |
| Internal Service/Other Funds | | | | | | |
| Equipment Services Operations | \$ 1,555,400.00 | \$ 433,561.52 | \$ - | \$ 433,561.52 | \$ 1,121,838.48 | 27.87% |
| Equipment Replacement Fund | - | 293,445.43 | 109,962.00 | 403,407.43 | (403,407.43) | #DIV/0! |
| Fund Total | <u>\$ 1,555,400.00</u> | <u>\$ 727,006.95</u> | <u>\$ 109,962.00</u> | <u>\$ 836,968.95</u> | <u>\$ 718,431.05</u> | 53.81% |
| Total | <u><u>\$ 49,500,268.00</u></u> | <u><u>\$ 19,152,971.49</u></u> | <u><u>\$ 1,813,848.91</u></u> | <u><u>\$ 20,966,820.40</u></u> | <u><u>\$ 28,533,447.60</u></u> | 42.36% |

**City of Muscatine
General Fund
Revenue Summary
For Fiscal Year 2025/2026 through November, 2025**

| | Budget | July through November Revenues | Year-To-Date Revenues | Variance over (under) Budget | Percentage |
|--|-------------------------|--------------------------------------|--------------------------|------------------------------------|------------|
| Direct and Indirect | | | | | |
| Property Tax Revenues | | | | | |
| General Property Taxes | \$ 8,700,009.00 | \$ 4,466,222.37 | \$ 4,466,222.37 | \$ (4,233,786.63) | 51.34% |
| Ag Land Taxes | 5,038.00 | 3,586.79 | 3,586.79 | (1,451.21) | 71.19% |
| Tort Liability Levy | 511,673.00 | 263,236.15 | 263,236.15 | (248,436.85) | 51.45% |
| Transit Tax Levy | 74,737.00 | 38,449.26 | 38,449.26 | (36,287.74) | 51.45% |
| Mobile Home Tax | 21,400.00 | 9,602.55 | 9,602.55 | (11,797.45) | 44.87% |
| Special Revenues : | | | | | |
| Police Retirement | 818,814.00 | 319,824.22 | 319,824.22 | (498,989.78) | 39.06% |
| Fire Retirement | 809,702.00 | 316,979.68 | 316,979.68 | (492,722.32) | 39.15% |
| Police and Fire Medical Insurance | 60,637.00 | - | - | (60,637.00) | 0.00% |
| Police and Fire Retiree Medical Costs | 60,000.00 | 7,703.56 | 7,703.56 | (52,296.44) | 12.84% |
| Long-Term Disability Insurance | 16,140.00 | 6,589.91 | 6,589.91 | (9,550.09) | 40.83% |
| Workers Compensation Insurance | 22,997.00 | 27,945.00 | 27,945.00 | 4,948.00 | 121.52% |
| Unemployment Insurance | 6,625.00 | 1,070.25 | 1,070.25 | (5,554.75) | 16.15% |
| Health Insurance | 2,674,075.00 | 1,066,075.26 | 1,066,075.26 | (1,607,999.74) | 39.87% |
| Life Insurance | 15,392.00 | 6,357.18 | 6,357.18 | (9,034.82) | 41.30% |
| Dental Insurance | 52,496.00 | 19,945.07 | 19,945.07 | (32,550.93) | 37.99% |
| Deferred Compensation | 104,637.00 | 2,328.43 | 2,328.43 | (102,308.57) | 2.23% |
| Post Employment Health Plan | 5,738.00 | - | - | (5,738.00) | 0.00% |
| FICA/IPERS | 968,089.00 | 395,103.28 | 395,103.28 | (572,985.72) | 40.81% |
| Employee Benefit Levy Reduction | - | - | - | - | |
| Subtotal | <u>\$ 14,928,199.00</u> | <u>\$ 6,951,018.96</u> | <u>\$ 6,951,018.96</u> | <u>\$ (7,977,180.04)</u> | 46.56% |
| Non-Property Tax Revenues | | | | | |
| Hotel/Motel Taxes | \$ 595,000.00 | \$ 143,413.09 | \$ 143,413.09 | \$ (451,586.91) | 24.10% |
| Cable Franchise Tax | 100,000.00 | - | - | (100,000.00) | 0.00% |
| Utility Franchise Fee | 500,000.00 | 39,117.02 | 39,117.02 | (460,882.98) | 7.82% |
| Utility Tax Replacement Excise Taxes: | | | | | |
| General | 31,098.00 | 13,880.20 | 13,880.20 | (17,217.80) | 44.63% |
| Tort Liability | 1,827.00 | 816.33 | 816.33 | (1,010.67) | 44.68% |
| Transit | 263.00 | 119.23 | 119.23 | (143.77) | 45.33% |
| Commercial/Industrial State Reimbursement: | | | | | |
| General | 159,934.00 | 79,966.23 | 79,966.23 | (79,967.77) | 50.00% |
| Tort Liability | 9,406.00 | 4,703.04 | 4,703.04 | (4,702.96) | 50.00% |
| Transit | 1,374.00 | 686.94 | 686.94 | (687.06) | 50.00% |
| Other State Contributions - Moneys & Credits | 5,500.00 | 6,479.78 | 6,479.78 | 979.78 | 117.81% |
| Business Property Tax Credit Reimbursement: | | | | | |
| General | 205,625.00 | 114,666.57 | 114,666.57 | (90,958.43) | 55.76% |
| Tort Liability | 12,093.00 | 6,743.87 | 6,743.87 | (5,349.13) | 55.77% |
| Transit | 1,766.00 | 985.03 | 985.03 | (780.97) | 55.78% |
| Subtotal | <u>\$ 1,623,886.00</u> | <u>\$ 411,577.33</u> | <u>\$ 411,577.33</u> | <u>\$ (1,212,308.67)</u> | 25.35% |

**City of Muscatine
General Fund
Revenue Summary
For Fiscal Year 2025/2026 through November, 2025**

| | Budget | July through November Revenues | Year-To-Date Revenues | Variance over (under) Budget | Percentage |
|-------------------------------------|-----------------|--------------------------------------|--------------------------|------------------------------------|------------|
| Intergovernmental Revenues | | | | | |
| Road Use Tax | \$ 3,784,200.00 | \$ 1,340,472.11 | \$ 1,340,472.11 | \$ (2,443,727.89) | 35.42% |
| Subtotal | \$ 3,784,200.00 | \$ 1,340,472.11 | \$ 1,340,472.11 | \$ (2,443,727.89) | 35.42% |
| Licenses and Permits | | | | | |
| Beer, Liquor and Cigarettes | \$ 40,000.00 | \$ 15,756.26 | \$ 15,756.26 | \$ (24,243.74) | 39.39% |
| Animal | 5,000.00 | - | - | (5,000.00) | 0.00% |
| Miscellaneous | 6,800.00 | 5,400.00 | 5,400.00 | (1,400.00) | 79.41% |
| Subtotal | \$ 51,800.00 | \$ 21,156.26 | \$ 21,156.26 | \$ (30,643.74) | 40.84% |
| Community Development | | | | | |
| Housing Inspection Fees | \$ 75,000.00 | \$ 30,737.48 | \$ 30,737.48 | \$ (44,262.52) | 40.98% |
| Section 8 Housing Inspection Fees | 8,200.00 | 3,435.00 | 3,435.00 | (4,765.00) | 41.89% |
| Construction Permits | 350,000.00 | 118,224.00 | 118,224.00 | (231,776.00) | 33.78% |
| Zoning Fees | 1,000.00 | 50.00 | 50.00 | (950.00) | 5.00% |
| Board of Adjustment Fees | 1,000.00 | 500.00 | 500.00 | (500.00) | 50.00% |
| Site Plan Review fees | 500.00 | 600.00 | 600.00 | 100.00 | 120.00% |
| Sale of Property | - | - | - | - | |
| Municipal Infractions Penalties | - | - | - | - | #DIV/0! |
| Nuisance Reimbursements | 145,000.00 | 53,660.33 | 53,660.33 | (91,339.67) | 37.01% |
| Donations - National Night Out | - | - | - | - | |
| Other | 500.00 | 139.00 | 139.00 | (361.00) | 27.80% |
| Historic Preservation Grant | - | 20,000.00 | 20,000.00 | 20,000.00 | |
| Subtotal | \$ 581,200.00 | \$ 227,345.81 | \$ 227,345.81 | \$ (353,854.19) | 39.12% |
| Police Revenues | | | | | |
| Police Grant | \$ 341,500.00 | \$ 59,053.77 | \$ 59,053.77 | \$ (282,446.23) | 17.29% |
| Court Fines | 160,000.00 | 57,717.25 | 57,717.25 | (102,282.75) | 36.07% |
| Parking Violations | 21,000.00 | 4,285.00 | 4,285.00 | (16,715.00) | 20.40% |
| Automatic Traffic Enforcement Fines | 250,000.00 | 122,829.60 | 122,829.60 | (127,170.40) | 49.13% |
| Tobacco Violations | 2,000.00 | 3,000.00 | 3,000.00 | 1,000.00 | 150.00% |
| Alarm System Charges | 3,000.00 | 1,600.00 | 1,600.00 | (1,400.00) | 53.33% |
| Alarm Permits | 600.00 | 225.00 | 225.00 | (375.00) | 37.50% |
| False Alarm Charges | 3,000.00 | 500.00 | 500.00 | (2,500.00) | 16.67% |
| Police Services Agreement | 63,800.00 | 32,081.50 | 32,081.50 | (31,718.50) | 50.28% |
| Printing Charges | 4,000.00 | 1,741.25 | 1,741.25 | (2,258.75) | 43.53% |
| Lease-Public Safety Cell Tower | 31,000.00 | 13,686.30 | 13,686.30 | (17,313.70) | 44.15% |
| Other Contribution | 3,000.00 | - | - | (3,000.00) | |
| Contribution for MSORT | - | - | - | 0.00 | |
| Animal Ordinance Fees and Fines | 4,500.00 | 3,495.00 | 3,495.00 | (1,005.00) | 77.67% |
| Other | 25,000.00 | 13,192.99 | 13,192.99 | (11,807.01) | 52.77% |
| Subtotal | \$ 912,400.00 | \$ 313,407.66 | \$ 313,407.66 | \$ (598,992.34) | 34.35% |

**City of Muscatine
General Fund
Revenue Summary
For Fiscal Year 2025/2026 through November, 2025**

| | Budget | July through November Revenues | Year-To-Date Revenues | Variance over (under) Budget | Percentage |
|--------------------------------------|----------------------|--------------------------------------|--------------------------|------------------------------------|---------------|
| Fire Revenues | | | | | |
| Fire Hazmat Agreements | \$ 26,800.00 | \$ - | \$ - | \$ (26,800.00) | 0.00% |
| Fire Protection Contracts | 24,400.00 | - | - | (24,400.00) | 0.00% |
| Open Burn Permits | 1,000.00 | 275.00 | 275.00 | (725.00) | 27.50% |
| Fire Inspection Fees | 12,000.00 | 2,265.00 | 2,265.00 | (9,735.00) | 18.88% |
| Confined Space Fees | 32,700.00 | 4,500.00 | 4,500.00 | (28,200.00) | 13.76% |
| Printing Charges | 100.00 | 30.00 | 30.00 | (70.00) | 30.00% |
| Fire Plan Review | 4,000.00 | 490.00 | 490.00 | (3,510.00) | 12.25% |
| Fire Alarm Permits | 1,800.00 | 150.00 | 150.00 | (1,650.00) | 8.33% |
| Donations | - | - | - | 0.00 | |
| Firework Fees | 2,600.00 | 200.00 | 200.00 | (2,400.00) | 7.69% |
| Insurance Reimbursements | - | 2,474.05 | 2,474.05 | 2,474.05 | #DIV/0! |
| FEMA - Equipment Reimbursement | - | 2,259.54 | 2,259.54 | 2,259.54 | |
| Other | 8,000.00 | 23,935.34 | 23,935.34 | 15,935.34 | 299.19% |
| Subtotal | \$ 113,400.00 | \$ 36,578.93 | \$ 36,578.93 | \$ (76,821.07) | 32.26% |
| Cemetery Fees | | | | | |
| Lot and Niche Sales | \$ 33,200.00 | \$ 9,410.00 | \$ 9,410.00 | \$ (23,790.00) | 28.34% |
| Lease of Property | 26,600.00 | 12,100.63 | 12,100.63 | (14,499.37) | 45.49% |
| Burial Fees | 37,300.00 | 12,045.00 | 12,045.00 | (25,255.00) | 32.29% |
| Miscellaneous Charges | 19,000.00 | 6,880.00 | 6,880.00 | (12,120.00) | 36.21% |
| Commissions | 25,000.00 | 1,750.00 | 1,750.00 | (23,250.00) | 7.00% |
| Perpetual Care Interest | 40,000.00 | 1,981.93 | 1,981.93 | (38,018.07) | 4.95% |
| Maintenance Fees (Cemetery Steps) | 400.00 | - | - | (400.00) | 0.00% |
| Other - Donation for Steps Sign | - | 852.00 | 852.00 | 852.00 | |
| Subtotal | \$ 181,500.00 | \$ 45,019.56 | \$ 45,019.56 | \$ (136,480.44) | 24.80% |
| Parks and Recreation Revenues | | | | | |
| Parks - General | | | | | |
| Shelters | \$ 12,400.00 | \$ 2,535.00 | \$ 2,535.00 | \$ (9,865.00) | 20.44% |
| Pearl City Station Rentals | 13,400.00 | 4,725.00 | 4,725.00 | (8,675.00) | 35.26% |
| Riverview Center Rentals | 32,400.00 | 18,500.00 | 18,500.00 | (13,900.00) | 57.10% |
| Maintenance Fees | 600.00 | 620.00 | 620.00 | 20.00 | 103.33% |
| Concession Commission | 200.00 | - | - | (200.00) | 0.00% |
| Dog Park Permits | 2,500.00 | - | - | (2,500.00) | 0.00% |
| Donations | 2,000.00 | 6,000.00 | 6,000.00 | 4,000.00 | 300.00% |
| Donations - Trees | - | - | - | - | |
| Other | - | 6,336.91 | 6,336.91 | 6,336.91 | |
| Transfers In: | | | | | |
| Administrative Fees | 13,700.00 | 3,425.00 | 3,425.00 | (10,275.00) | 25.00% |
| Subtotal | \$ 77,200.00 | \$ 42,141.91 | \$ 42,141.91 | \$ (35,058.09) | 54.59% |

**City of Muscatine
General Fund
Revenue Summary
For Fiscal Year 2025/2026 through November, 2025**

| | Budget | July through November Revenues | Year-To-Date Revenues | Variance over (under) Budget | Percentage |
|----------------------------------|----------------------|--------------------------------------|--------------------------|------------------------------------|------------|
| Kent Stein Park | | | | | |
| Maintenance Fees (Inc. Bruner) | \$ 27,500.00 | \$ 15,865.00 | \$ 15,865.00 | \$ (11,635.00) | 57.69% |
| Commission on Concessions | 5,500.00 | 1,088.48 | 1,088.48 | (4,411.52) | 19.79% |
| Mowing Reimbursement-Housing | 7,700.00 | - | - | (7,700.00) | 0.00% |
| Storage Building Rental | 1,200.00 | - | - | (1,200.00) | 0.00% |
| Other | - | - | - | - | |
| Subtotal | <u>\$ 41,900.00</u> | <u>\$ 16,953.48</u> | <u>\$ 16,953.48</u> | <u>\$ (24,946.52)</u> | 40.46% |
| Soccer Complex Operations | | | | | |
| Maintenance Fees | \$ 52,400.00 | \$ 9,880.00 | \$ 9,880.00 | \$ (42,520.00) | 18.85% |
| Commission on Concessions | 5,800.00 | 2,586.41 | 2,586.41 | (3,213.59) | 44.59% |
| Subtotal | <u>\$ 58,200.00</u> | <u>\$ 12,466.41</u> | <u>\$ 12,466.41</u> | <u>\$ (45,733.59)</u> | 21.42% |
| Recreation | | | | | |
| Entry Fees/Admissions | \$ 1,500.00 | \$ - | \$ - | \$ (1,500.00) | 0.00% |
| Lessons | 25,300.00 | 9,875.00 | 9,875.00 | (15,425.00) | 39.03% |
| League and Tournament Fees | 5,000.00 | 4,050.00 | 4,050.00 | (950.00) | 81.00% |
| Sales Tax | 400.00 | - | - | (400.00) | 0.00% |
| Donations | 1,700.00 | - | - | (1,700.00) | 0.00% |
| Other | - | - | - | 0.00 | |
| Subtotal | <u>\$ 33,900.00</u> | <u>\$ 13,925.00</u> | <u>\$ 13,925.00</u> | <u>\$ (19,975.00)</u> | 41.08% |
| Aquatic Center | | | | | |
| Admissions | \$ 108,600.00 | \$ 48,077.45 | \$ 48,077.45 | \$ (60,522.55) | 44.27% |
| Season Passes | 12,000.00 | 455.00 | 455.00 | (11,545.00) | 3.79% |
| Lessons | 13,600.00 | - | - | (13,600.00) | 0.00% |
| Group Sales | 20,000.00 | 1,800.00 | 1,800.00 | (18,200.00) | 9.00% |
| Room Rentals | 900.00 | 790.00 | 790.00 | (110.00) | 87.78% |
| Locker Rental | 300.00 | 201.75 | 201.75 | (98.25) | 67.25% |
| Commission on Concessions | 6,000.00 | 4,786.63 | 4,786.63 | (1,213.37) | 79.78% |
| Miscellaneous Sales | 300.00 | - | - | (300.00) | 0.00% |
| Other | - | 55.00 | 55.00 | 55.00 | |
| Subtotal | <u>\$ 161,700.00</u> | <u>\$ 56,165.83</u> | <u>\$ 56,165.83</u> | <u>\$ (105,534.17)</u> | 34.73% |
| Indoor Sports Dome | | | | | |
| Facility Usage Charges | \$ 250,000.00 | \$ 15,595.00 | \$ 15,595.00 | \$ (234,405.00) | 6.24% |
| Sponsorships | 10,000.00 | - | - | (10,000.00) | |
| Commission on Concessions | 20,000.00 | - | - | (20,000.00) | |
| Entry Fees | - | 515.00 | 515.00 | 515.00 | |
| Court Fees | - | 400.03 | 400.03 | 400.03 | |
| Sales Tax | - | 64.05 | 64.05 | 64.05 | |
| Other | - | 0.06 | 0.06 | 0.06 | |
| Subtotal | <u>\$ 280,000.00</u> | <u>\$ 16,574.14</u> | <u>\$ 16,574.14</u> | <u>\$ (263,425.86)</u> | 5.92% |
| Subtotal - Parks and Recreation | <u>\$ 652,900.00</u> | <u>\$ 158,226.77</u> | <u>\$ 158,226.77</u> | <u>\$ (494,673.23)</u> | 24.23% |

**City of Muscatine
General Fund
Revenue Summary
For Fiscal Year 2025/2026 through November, 2025**

| | Budget | July through November Revenues | Year-To-Date Revenues | Variance over (under) Budget | Percentage |
|--|----------------------|--------------------------------------|--------------------------|------------------------------------|------------|
| Library Revenues | | | | | |
| County Contributions | \$ 138,000.00 | \$ 67,056.00 | \$ 67,056.00 | \$ (70,944.00) | 48.59% |
| Illinois Contracts | 10,600.00 | 10,883.55 | 10,883.55 | 283.55 | 102.68% |
| Printing Charges | 4,000.00 | 1,864.50 | 1,864.50 | (2,135.50) | 46.61% |
| Other | - | 271.17 | 271.17 | 271.17 | |
| | | - | - | | |
| Subtotal | <u>\$ 152,600.00</u> | <u>\$ 80,075.22</u> | <u>\$ 80,075.22</u> | <u>\$ (72,524.78)</u> | 52.47% |
| Art Center Revenues | | | | | |
| Building Rentals | \$ 200.00 | \$ 130.00 | \$ 130.00 | \$ (70.00) | 65.00% |
| Class Fees | 4,500.00 | 2,344.50 | 2,344.50 | (2,155.50) | 52.10% |
| State Grant | 15,000.00 | - | - | (15,000.00) | 0.00% |
| Friends of the Art Center Contribution | 31,900.00 | - | - | (31,900.00) | 0.00% |
| Support Foundation Contribution | 28,700.00 | - | - | (28,700.00) | 0.00% |
| Other Contributions (American Queen) | 6,500.00 | 5,500.00 | 5,500.00 | (1,000.00) | 84.62% |
| Other Contributions (Carver Trust) | 11,700.00 | 11,710.00 | 11,710.00 | 10.00 | 100.09% |
| Other | 300.00 | 162.00 | 162.00 | (138.00) | 54.00% |
| | | - | - | | |
| Subtotal | <u>\$ 98,800.00</u> | <u>\$ 19,846.50</u> | <u>\$ 19,846.50</u> | <u>\$ (78,953.50)</u> | 20.09% |
| Public Works Services | | | | | |
| Repair and Maintenance Services | \$ 17,500.00 | \$ - | \$ - | \$ (17,500.00) | 0.00% |
| Rental of Equipment | 300.00 | - | - | (300.00) | 0.00% |
| Sales of Equipment | 1,000.00 | 2,109.43 | 2,109.43 | 1,109.43 | 0.00% |
| Miscellaneous Sales | 2,500.00 | - | - | (2,500.00) | 0.00% |
| Reimbursement for Salt | 5,000.00 | - | - | (5,000.00) | 0.00% |
| Reimbursement of Expenses | - | 320.82 | 320.82 | 320.82 | |
| Reimbursement of Damages | - | - | - | - | |
| Other | - | - | - | - | |
| Transfers In: | | - | - | | |
| Engineering Services | 180,000.00 | - | - | (180,000.00) | 0.00% |
| Administrative Fees | 83,800.00 | 20,950.00 | 20,950.00 | (62,850.00) | 25.00% |
| Subtotal | <u>\$ 290,100.00</u> | <u>\$ 23,380.25</u> | <u>\$ 23,380.25</u> | <u>\$ (266,719.75)</u> | 8.06% |

**City of Muscatine
General Fund
Revenue Summary
For Fiscal Year 2025/2026 through November, 2025**

| | Budget | July through November Revenues | Year-To-Date Revenues | Variance over (under) Budget | Percentage |
|---|--------------------------------|--------------------------------------|--------------------------------|------------------------------------|------------|
| Other General Revenues | | | | | |
| Interest Income | 250,000.00 | - | - | (250,000.00) | 0.00% |
| Payment in Lieu of Taxes | 39,000.00 | - | - | (39,000.00) | 0.00% |
| Housing Accounting Fees | 77,000.00 | - | - | (77,000.00) | 0.00% |
| Other Charges | 20,000.00 | 4,371.84 | 4,371.84 | (15,628.16) | 21.86% |
| ICAP Refund | - | - | - | 0.00 | |
| Transfers In : | | | | | |
| Administrative Fees | 442,700.00 | 110,675.00 | 110,675.00 | (332,025.00) | 25.00% |
| Health Insurance Fund | 70,500.00 | 11,014.62 | 11,014.62 | (59,485.38) | 15.62% |
| Health Insurance Admin Fee | 3,000.00 | - | - | (3,000.00) | 0.00% |
| Computer Operations Admin Fee | 52,100.00 | 11,100.00 | 11,100.00 | (41,000.00) | 21.31% |
| Communications Admin Fe (Exc TIF portion) | 80,000.00 | - | - | (80,000.00) | 0.00% |
| Ambulance Enterprise Fund-Admin | 1,630,300.00 | 407,575.00 | 407,575.00 | (1,222,725.00) | 25.00% |
| Ambulance Enterprise Fund-Add'l GEMT | 244,200.00 | 61,050.00 | 61,050.00 | (183,150.00) | 25.00% |
| Tax Increment Economic Development | 210,400.00 | - | - | (210,400.00) | 0.00% |
| Tax Increment Administrative Fees | 43,000.00 | - | - | (43,000.00) | 0.00% |
| Emergency Fund - State COVID Relief | 350,000.00 | - | - | (350,000.00) | 0.00% |
| Subtotal | <u>\$ 3,512,200.00</u> | <u>\$ 605,786.46</u> | <u>\$ 605,786.46</u> | <u>\$ (2,906,413.54)</u> | 17.25% |
| Total | <u><u>\$ 26,883,185.00</u></u> | <u><u>\$ 10,233,891.82</u></u> | <u><u>\$ 10,233,891.82</u></u> | <u><u>\$ (16,649,293.18)</u></u> | 38.07% |

Muscatine Power and Water
Electric Utility
Financial Operating Statements & Balance Sheets
December 2025

**Muscatine Power and Water
Electric Utility
Table of Contents**

| | |
|--|---------------|
| Classification of Electric Energy Distribution | 1 |
| Statements of Revenues, Expenses, and Changes in Net Position | 2 - 3 |
| Statements of Net Position | 4 - 5 |
| Statements of Cash Flows | 6 |
| Summary of Expenses | 7 - 12 |
| Rates | 13 |
| Statistical Data | 14 |
| Wholesale Margins Analysis | 15 |
| Wind Margins Analysis | 16 |

Muscatine Power and Water - Electric Utility
Classification of Electric Energy Sales
Current Month - December 2025

| kWh | Results | | | Variance | | | | Average Use Per Customer | |
|--|-------------------|-------------------|-------------------|--------------------|--------------|--------------------|--------------|--------------------------|-------------------|
| | Actual | Budget | Prior Year | Vs Budget | % | Vs Prior Yr | % | | |
| kWh Generated and Sold | | | | | | | | | |
| Gross Generation | 94,586,844 | 69,871,878 | 81,964,854 | 24,714,966 | 35.4% | 12,621,990 | 15.4% | | |
| less: Plant Use | 8,560,545 | 7,709,283 | 7,867,839 | 851,262 | 11.0% | 692,706 | 8.8% | | |
| Net Generation/Wholesale Sales | 86,026,299 | 62,162,596 | 74,097,015 | 23,863,703 | 38.4% | 11,929,284 | 16.1% | | |
| Wholesale Sales - Wind | 5,419,400 | 4,662,443 | 4,209,400 | 756,957 | 16.2% | 1,210,000 | 28.7% | | |
| Total Wholesale Sales | 91,445,699 | 66,825,039 | 78,306,415 | 24,620,660 | 36.8% | 13,139,284 | 16.8% | | |
| Net Capacity Factors | | | | | | | | | |
| Unit 9 | 72.6% | 56.1% | 62.8% | 16.5% | | 9.8% | | | |
| Unit 8 | 0.0% | 0.0% | 0.0% | 0.0% | | 0.0% | | | |
| Unit 7 | 0.0% | 0.0% | 0.0% | 0.0% | | 0.0% | | | |
| Total Plant | 45.6% | 35.0% | 39.1% | 10.7% | | 6.5% | | | |
| SF Wind | 56.0% | 48.2% | 43.5% | | | | | | |
| kWh Distributed | | | | | | | | Actual | Prior Year |
| Residential ^{fm1} | 7,356,148 | 7,553,360 | 7,829,136 | (197,212) | -2.6% | (472,988) | -6.0% | 728 | 773 |
| Commercial I ^{fm2} | 2,153,274 | 2,114,912 | 2,404,604 | 38,362 | 1.8% | (251,330) | -10.5% | 1,559 | 1,756 |
| Commercial II | 8,225,435 | 7,200,662 | 7,208,729 | 1,024,774 | 14.2% | 1,016,706 | 14.1% | 50,155 | 46,210 |
| Industrial I | 9,396,160 | 12,016,970 | 9,860,320 | (2,620,810) | -21.8% | (464,160) | -4.7% | 671,154 | 704,309 |
| Industrial II | 41,396,828 | 42,346,067 | 43,173,996 | (949,239) | -2.2% | (1,777,168) | -4.1% | 20,698,414 | 21,586,998 |
| City Enterprise Funds | 475,149 | 488,902 | 512,224 | (13,753) | -2.8% | (37,075) | -7.2% | 18,275 | 19,701 |
| Inter-Utility | 1,205,346 | 1,530,620 | 1,338,837 | (325,274) | -21.3% | (133,491) | -10.0% | 34,438 | 39,378 |
| Retail Sales | 70,208,340 | 73,251,492 | 72,327,846 | (3,043,152) | -4.2% | (2,119,506) | -2.9% | 5,987 | 6,169 |
| City Lighting | 120,682 | 92,120 | 119,096 | 28,562 | 31.0% | 1,586 | 1.3% | | |
| City Buildings | 626,481 | 581,976 | 571,141 | 44,505 | 7.6% | 55,340 | 9.7% | | |
| Offline Power Plant Usage | 480,245 | 348,936 | 503,502 | 131,309 | 37.6% | (23,258) | -4.6% | | |
| Losses & Cycle Billing | 4,251,682 | 3,783,364 | 2,841,645 | 468,317 | 12.4% | 1,410,037 | 49.6% | | |
| Total Retail kWh Distributed | 75,687,430 | 78,057,889 | 76,363,230 | (2,370,460) | -3.0% | (675,801) | -0.9% | | |
| Wind kWh Purchases | 5,419,400 | 4,662,443 | 4,209,400 | 756,957 | 16.2% | 1,210,000 | 28.7% | | |
| Total Purchased Electricity kWh | 81,106,830 | 82,720,332 | 80,572,630 | (1,613,503) | -2.0% | 534,199 | 0.7% | | |

^{fm1} Includes an adjustment for unbilled kWh of (165,520) for 2025 and 38,889 for 2024

^{fm2} Includes an adjustment for unbilled kWh of (48,703) for 2025 and (54,264) for 2024

| kWh | Results | | | Variance | | | | Average Use Per Customer | |
|--|--------------------|--------------------|--------------------|---------------------|--------------|--------------------|--------------|--------------------------|-------------------|
| | Actual | Budget | Prior Year | Vs Budget | % | Vs Prior Yr | % | | |
| kWh Generated and Sold | | | | | | | | | |
| Gross Generation | 839,204,092 | 701,271,910 | 625,981,203 | 137,932,182 | 19.7% | 213,222,889 | 34.1% | | |
| less: Plant Use | 84,466,844 | 77,467,891 | 65,344,870 | 6,998,953 | 9.0% | 19,121,974 | 29.3% | | |
| Net Generation/Wholesale Sales | 754,737,248 | 623,804,019 | 560,636,333 | 130,933,229 | 21.0% | 194,100,915 | 34.6% | | |
| Wholesale Sales - Wind | 54,467,900 | 50,451,504 | 52,318,990 | 4,016,396 | 8.0% | 2,148,910 | 4.1% | | |
| Total Wholesale Sales | 809,205,148 | 674,255,523 | 612,955,323 | 134,949,625 | 20.0% | 196,249,825 | 32.0% | | |
| Net Capacity Factors | | | | | | | | | |
| Unit 9 | 50.0% | 44.0% | 37.3% | 5.9% | | 12.6% | | | |
| Unit 8 | 6.6% | 6.2% | 4.8% | 0.4% | | 2% | | | |
| Unit 7 | 8.4% | 6.2% | 4.7% | 2.2% | | 3.7% | | | |
| Total Plant | 34.0% | 29.8% | 25.1% | 4.2% | | 8.9% | | | |
| SF Wind | 47.8% | 44.3% | 45.8% | | | | | | |
| kWh Distributed | | | | | | | | Actual | Prior Year |
| Residential ^{fm1} | 101,039,446 | 100,216,728 | 98,118,522 | 822,718 | 0.8% | 2,920,924 | 3.0% | 9,999 | 9,693 |
| Commercial I ^{fm2} | 28,906,072 | 28,043,398 | 28,781,954 | 862,674 | 3.1% | 124,118 | 0.4% | 20,931 | 21,024 |
| Commercial II | 93,251,461 | 90,976,739 | 87,543,638 | 2,274,722 | 2.5% | 5,707,823 | 6.5% | 568,606 | 561,177 |
| Industrial I | 135,383,760 | 151,201,015 | 144,210,100 | (15,817,255) | -10.5% | (8,826,340) | -6.1% | 9,670,269 | 10,300,721 |
| Industrial II | 493,772,843 | 498,417,615 | 493,560,790 | (4,644,772) | -0.9% | 212,053 | 0.0% | 246,886,422 | 246,780,395 |
| City Enterprise Funds | 5,404,549 | 5,664,751 | 5,700,637 | (260,202) | -4.6% | (296,088) | -5.2% | 207,867 | 219,255 |
| Inter-Utility | 15,920,019 | 18,546,898 | 16,727,272 | (2,626,879) | -14.2% | (807,253) | -4.8% | 454,858 | 491,979 |
| Retail Sales | 873,678,150 | 893,067,144 | 874,642,913 | (19,388,994) | -2.2% | (964,763) | -0.1% | 74,501 | 74,603 |
| City Lighting | 1,450,466 | 1,336,472 | 1,390,033 | 113,994 | 8.5% | 60,433 | 4.3% | | |
| City Buildings | 6,522,001 | 6,637,547 | 6,267,074 | (115,546) | -1.7% | 254,927 | 4.1% | | |
| Offline Power Plant Usage | 6,539,837 | 6,873,144 | 8,813,506 | (333,307) | -4.8% | (2,273,669) | -25.8% | | |
| Losses & Cycle Billing | 25,950,089 | 26,586,994 | 25,282,656 | (636,906) | -2.4% | 667,432 | 2.6% | | |
| Total Retail kWh Distributed | 914,140,543 | 934,501,301 | 916,396,182 | (20,360,759) | -2.2% | (2,255,640) | -0.2% | | |
| Wind kWh Purchases | 54,467,900 | 50,451,504 | 52,318,990 | 4,016,396 | 8.0% | 2,148,910 | 4.1% | | |
| Total Purchased Electricity kWh | 968,608,443 | 984,952,805 | 968,715,172 | (16,344,362) | -1.7% | (106,730) | 0.0% | | |

^{fm1} Includes an adjustment for unbilled kWh of (165,520) for 2025 and 38,889 for 2024

^{fm2} Includes an adjustment for unbilled kWh of (48,703) for 2025 and (54,264) for 2024

Muscatine Power and Water - Electric Utility
Statements of Revenues, Expenses, and Changes in Net Position
Current Month - December 2025

| Income Statement | Results | | | Variance | | | |
|---|-----------------------|-----------------------|-----------------------|---------------------|---------------|-----------------------|---------------|
| | Actual | Budget | Prior Year | Vs Budget \$ | % | Vs Prior Yr \$ | % |
| Sales of Electricity | | | | | | | |
| Residential ^{m1} | \$ 982,945 | \$ 1,030,617 | \$ 1,000,750 | \$ (47,672) | -4.6% | \$ (17,805) | -1.8% |
| Commercial I ^{m2} | 264,259 | 273,944 | 292,182 | (9,684) | -3.5% | (27,923) | -9.6% |
| Commercial II | 755,679 | 639,102 | 672,638 | 116,576 | 18.2% | 83,041 | 12.3% |
| Industrial I | 716,267 | 930,704 | 764,922 | (214,437) | -23.0% | (48,655) | -6.4% |
| Industrial II | 2,526,259 | 2,695,012 | 2,641,025 | (168,753) | -6.3% | (114,766) | -4.3% |
| City Enterprise Funds | 43,457 | 41,512 | 44,412 | 1,945 | 4.7% | (955) | -2.2% |
| Inter-Utility | 97,889 | 121,041 | 99,021 | (23,152) | -19.1% | (1,132) | -1.1% |
| Security Lights | 23,609 | 22,833 | 23,441 | 775 | 3.4% | 167 | 0.7% |
| Retail Sales Total | 5,410,364 | 5,754,765 | 5,538,392 | (344,401) | -6.0% | (128,027) | -2.3% |
| Wholesale Sales - Energy | 4,023,409 | 2,377,110 | 2,767,955 | 1,646,299 | 69.3% | 1,255,454 | 45.4% |
| Wholesale Sales - Capacity | 329,571 | 34,410 | 3,571 | 295,161 | 857.8% | 326,000 | NM |
| Total Sales of Electricity | 9,763,345 | 8,166,286 | 8,309,918 | 1,597,059 | 19.6% | 1,453,427 | 17.5% |
| Byproduct Revenue | 105,401 | 90,722 | 102,261 | 14,679 | 16.2% | 3,139 | 3.1% |
| Inter-Utility Rent Revenue | 19,594 | 19,594 | 19,023 | - | 0.0% | 571 | 3.0% |
| Miscellaneous Revenue | 108,875 | 88,148 | 142,565 | 20,726 | 23.5% | (33,690) | -23.6% |
| Other Revenue | 233,869 | 198,464 | 263,849 | 35,405 | 17.8% | (29,980) | -11.4% |
| Total Operating Revenue | 9,997,214 | 8,364,749 | 8,573,767 | 1,632,464 | 19.5% | 1,423,447 | 16.6% |
| Operating Expense | | | | | | | |
| Purchased Electricity - Energy | 3,303,149 | 2,536,176 | 2,650,747 | (766,973) | -30.2% | (652,402) | -24.6% |
| Purchased Electricity - Demand | 203,195 | 23,618 | 3,571 | (179,577) | -760.3% | (199,624) | NM |
| Production Fuel | 2,350,773 | 1,801,965 | 2,263,181 | (548,808) | -30.5% | (87,592) | -3.9% |
| Operation | 536,666 | 922,506 | 624,398 | 385,839 | 41.8% | 87,732 | 14.1% |
| Maintenance | 972,410 | 637,476 | 513,081 | (334,934) | -52.5% | (459,328) | -89.5% |
| Generation Labor | 675,274 | 621,498 | 626,663 | (53,776) | -8.7% | (48,612) | -7.8% |
| T&D Labor | 477,163 | 415,704 | 404,879 | (61,459) | -14.8% | (72,284) | -17.9% |
| A&G Labor | 471,658 | 403,405 | 434,342 | (68,253) | -16.9% | (37,316) | -8.6% |
| A&G | 1,174,956 | 1,138,328 | 345,953 | (36,629) | -3.2% | (829,004) | -239.6% |
| Total Operating Expense | 10,165,245 | 8,500,675 | 7,866,815 | (1,664,570) | -19.6% | (2,298,430) | -29.2% |
| Operating Margin | (168,031) | (135,925) | 706,952 | (32,106) | -23.6% | (874,983) | NM |
| Depreciation & Amortization | 651,222 | 626,407 | 632,509 | (24,815) | -4.0% | (18,713) | -3.0% |
| Depreciation - Plant Decommissioning | 681,931 | 132,796 | 132,796 | (549,135) | -413.5% | (549,135) | -413.5% |
| Operating Income/(Loss) | (1,501,183) | (895,128) | (58,353) | (606,055) | -67.7% | (1,442,831) | NM |
| Nonoperating Income/(Expense) | | | | | | | |
| Interest Income | 257,946 | 524,494 | 243,160 | (266,548) | -50.8% | 14,786 | 6.1% |
| Interest During Construction | 27,279 | 57,131 | 60,280 | (29,852) | -52.3% | (33,001) | -54.7% |
| Interest Expense | (7,636) | (818,185) | 1,787 | 810,548 | 99.1% | (9,423) | NM |
| Gain/(Loss) on Disposal of Assets | 6,581 | - | 8,101 | 6,581 | NM | (1,519) | -18.8% |
| Net Nonoperating Income/(Expense) | 284,170 | (236,560) | 313,328 | 520,730 | NM | (29,158) | -9.3% |
| Net Income/(Loss) Before Capital Contributions | (1,217,013) | (1,131,688) | 254,975 | (85,325) | -7.5% | (1,471,988) | NM |
| Capital Contributions | 16,990 | - | 241,165 | 16,990 | NM | (224,175) | -93.0% |
| Net Income | \$ (1,200,023) | \$ (1,131,688) | \$ 496,140 | \$ (68,335) | -6.0% | \$ (1,696,163) | NM |
| Beginning Net Position | 131,359,214 | 129,269,619 | 127,265,582 | 2,089,595 | 1.6% | 4,093,632 | 3.2% |
| Change in Net Position | (1,200,023) | (1,131,688) | 496,140 | (68,335) | -6.0% | (1,696,163) | NM |
| ENDING NET POSITION | \$ 130,159,191 | \$ 128,137,931 | \$ 127,761,722 | \$ 2,021,260 | 1.6% | \$ 2,397,469 | 1.9% |

Muscatine Power and Water - Electric Utility
Statements of Revenues, Expenses, and Changes in Net Position
Year To Date - December 2025

| Income Statement | Results | | | Variance | | | |
|---|-----------------------|-----------------------|-----------------------|---------------------|---------------|---------------------|---------------|
| | Actual | Budget | Prior Year | Vs Budget \$ | % | Vs Prior Yr \$ | % |
| Sales of Electricity | | | | | | | |
| Residential ^{m1} | \$ 13,027,343 | \$ 13,092,085 | \$ 12,394,204 | \$ (64,741) | -0.5% | \$ 633,139 | 5.1% |
| Commercial I ^{m2} | 3,551,372 | 3,507,485 | 3,462,441 | 43,887 | 1.3% | 88,931 | 2.6% |
| Commercial II | 8,748,525 | 7,978,621 | 8,119,054 | 769,903 | 9.6% | 629,471 | 7.8% |
| Industrial I | 10,082,463 | 11,508,973 | 10,553,265 | (1,426,510) | -12.4% | (470,802) | -4.5% |
| Industrial II | 30,772,516 | 31,464,061 | 30,180,615 | (691,545) | -2.2% | 591,900 | 2.0% |
| City Enterprise Funds | 512,297 | 475,505 | 505,645 | 36,792 | 7.7% | 6,652 | 1.3% |
| Inter-Utility | 1,205,051 | 1,442,057 | 1,226,909 | (237,006) | -16.4% | (21,857) | -1.8% |
| Security Lights | 286,077 | 274,000 | 278,872 | 12,077 | 4.4% | 7,205 | 2.6% |
| Retail Sales Total | 68,185,645 | 69,742,788 | 66,721,006 | (1,557,143) | -2.2% | 1,464,639 | 2.2% |
| Wholesale Sales - Energy | 37,676,520 | 26,220,079 | 20,528,557 | 11,456,441 | 43.7% | 17,147,963 | 83.5% |
| Wholesale Sales - Capacity | 11,981,100 | 4,696,590 | 1,162,345 | 7,284,509 | 155.1% | 10,818,755 | 930.8% |
| Total Sales of Electricity | 117,843,265 | 100,659,457 | 88,411,908 | 17,183,808 | 17.1% | 29,431,357 | 33.3% |
| Byproduct Revenue | 1,078,950 | 838,999 | 872,222 | 239,951 | 28.6% | 206,728 | 23.7% |
| Inter-Utility Rent Revenue | 235,123 | 235,123 | 228,275 | - | 0.0% | 6,848 | 3.0% |
| Miscellaneous Revenue | 1,984,227 | 1,057,779 | 1,486,703 | 926,448 | 87.6% | 497,524 | 33.5% |
| Other Revenue | 3,298,300 | 2,131,901 | 2,587,199 | 1,166,399 | 54.7% | 711,101 | 27.5% |
| Total Operating Revenue | 121,141,566 | 102,791,358 | 90,999,107 | 18,350,207 | 17.9% | 30,142,458 | 33.1% |
| Operating Expense | | | | | | | |
| Purchased Electricity - Energy | 37,029,648 | 32,455,271 | 27,041,018 | (4,574,377) | -14.1% | (9,988,630) | -36.9% |
| Purchased Electricity - Demand | 8,185,711 | 3,119,494 | 790,763 | (5,066,216) | -162.4% | (7,394,947) | -935.2% |
| Production Fuel | 21,045,635 | 18,027,817 | 15,907,886 | (3,017,817) | -16.7% | (5,137,749) | -32.3% |
| Operation | 6,875,680 | 6,995,071 | 6,259,919 | 119,391 | 1.7% | (615,762) | -9.8% |
| Maintenance | 7,258,247 | 6,398,588 | 8,635,155 | (859,659) | -13.4% | 1,376,908 | 15.9% |
| Generation Labor | 8,726,948 | 7,809,651 | 8,226,701 | (917,297) | -11.7% | (500,247) | -6.1% |
| T&D Labor | 5,292,750 | 4,922,396 | 4,736,453 | (370,354) | -7.5% | (556,297) | -11.7% |
| A&G Labor | 4,980,140 | 4,747,703 | 4,865,525 | (232,437) | -4.9% | (114,615) | -2.4% |
| A&G | 9,867,492 | 10,865,798 | 10,200,142 | 998,306 | 9.2% | 332,650 | 3.3% |
| Total Operating Expense | 109,262,251 | 95,341,790 | 86,663,561 | (13,920,461) | -14.6% | (22,598,689) | -26.1% |
| Operating Margin | 11,879,315 | 7,449,569 | 4,335,546 | 4,429,746 | 59.5% | 7,543,769 | 174.0% |
| Depreciation & Amortization | 7,540,096 | 7,516,847 | 7,086,591 | (23,249) | -0.3% | (453,505) | -6.4% |
| Depreciation - Plant Decommissioning | 4,888,358 | 1,593,548 | 1,593,548 | (3,294,810) | -206.8% | (3,294,810) | -206.8% |
| Operating Income/(Loss) | (549,139) | (1,660,826) | (4,344,592) | 1,111,687 | 66.9% | 3,795,454 | 87.4% |
| Nonoperating Income/(Expense) | | | | | | | |
| Interest Income | 2,721,263 | 3,806,016 | 3,267,497 | (1,084,754) | -28.5% | (546,234) | -16.7% |
| Interest During Construction | 268,193 | 685,573 | 60,280 | (417,380) | -60.9% | 207,913 | NM |
| Interest Expense | (112,253) | (2,454,554) | (71,120) | 2,342,302 | 95.4% | (41,133) | -57.8% |
| Gain/(Loss) on Disposal of Assets | 43,905 | - | 1,890 | 43,905 | NM | 42,015 | NM |
| Net Nonoperating Income/(Expense) | 2,921,108 | 2,037,035 | 3,258,547 | 884,073 | 43.4% | (337,439) | -10.4% |
| Net Income/(Loss) Before Capital Contributions | 2,371,969 | 376,209 | (1,086,046) | 1,995,760 | 530.5% | 3,458,015 | NM |
| Capital Contributions | 25,500 | - | 316,664 | 25,500 | NM | (291,164) | -91.9% |
| Net Income | \$ 2,397,469 | \$ 376,209 | \$ (769,382) | \$ 2,021,260 | 537.3% | \$ 3,166,851 | NM |
| Beginning Net Position | 127,761,722 | 127,761,722 | 128,531,104 | - | 0.0% | (769,382) | -0.6% |
| Change in Net Position | 2,397,469 | 376,209 | (769,382) | 2,021,260 | 537.3% | 3,166,851 | NM |
| ENDING NET POSITION | \$ 130,159,191 | \$ 128,137,931 | \$ 127,761,722 | \$ 2,021,260 | 1.6% | \$ 2,397,469 | 1.9% |

Muscatine Power and Water - Electric Utility
Statement of Net Position
December 2025

| ASSETS | | | |
|---|-----------------------|-----------------------|-----------------------|
| | 2025 | Prior Month | Prior Year |
| Current Assets: | | | |
| Cash - Interest Bearing | \$ 20,503,432 | \$ 9,711,973 | \$ 12,595,621 |
| Cash - Refundable Deposit | 270,000 | 270,000 | 270,000 |
| Investments - Securities | 44,287,687 | 48,287,687 | 44,378,872 |
| Investments - Plant Decommissioning | 8,075,453 | 7,393,522 | 3,187,095 |
| Receivables: | | | |
| Consumer Accounts | 7,508,642 | 9,041,889 | 7,609,421 |
| Refined Coal | - | - | - |
| Wholesale | 575,520 | 819,852 | 208,421 |
| Steam Sales | - | - | - |
| Interest | 893,895 | 944,355 | 844,909 |
| Inventories | 4,842,460 | 4,765,743 | 5,051,439 |
| Fuel | 10,211,403 | 12,445,453 | 17,062,543 |
| Prepaid Expenses | 1,146,768 | 1,384,958 | 888,910 |
| Total Current Assets | 98,315,262 | 95,065,433 | 92,097,232 |
| Non-Current Assets: | | | |
| Capital Assets: | | | |
| Property, Plant & Equipment | 452,166,895 | 451,338,948 | 446,293,048 |
| Subscription-Based IT Assets | 1,989,086 | 1,989,086 | 1,431,536 |
| Construction Work in Progress | 13,624,165 | 13,500,948 | 7,487,983 |
| Less: Accumulated Depreciation & Amortization | (385,502,032) | (384,891,208) | (378,082,427) |
| Total Capital Assets | 82,278,113 | 81,937,774 | 77,130,140 |
| Other Assets: | | | |
| Note Receivable from Comm Utility | - | 2,609,637 | 2,609,637 |
| Note Receivable from Water Utility | - | 1,356,044 | 1,490,629 |
| Joint Venture Rights | 160,931 | 171,501 | 153,040 |
| Net Pension Asset | - | - | - |
| Total Other Assets | 160,931 | 4,137,182 | 4,253,307 |
| Total Non-Current Assets | 82,439,044 | 86,074,956 | 81,383,447 |
| Deferred Outflows of Resources: | | | |
| Pension | 4,032,258 | 10,240,730 | 7,633,070 |
| OPEB | 437,266 | 134,348 | 163,079 |
| IPERS | 54,069 | 54,069 | 54,069 |
| Plant Decommissioning | 48,547,126 | 49,229,057 | 8,824,905 |
| Total Deferred Outflows of Resources | 53,070,719 | 59,658,203 | 16,675,123 |
| TOTAL ASSETS | \$ 233,825,024 | \$ 240,798,592 | \$ 190,155,802 |

Muscatine Power and Water - Electric Utility
Statement of Net Position
December 2025

| LIABILITIES AND NET POSITION | | | |
|--|-----------------------|-----------------------|-----------------------|
| | 2025 | Prior Month | Prior Year |
| Current Liabilities: | | | |
| Accounts Payable | \$ 1,803,428 | \$ 1,722,617 | \$ 1,891,908 |
| Health & Dental Insurance Provision | 163,610 | 223,364 | 223,364 |
| Accrued Payroll | 598,648 | 310,946 | 381,717 |
| Accrued Compensated Absences | 1,777,594 | 1,804,081 | 1,846,450 |
| Accrued Emission Allowance Expense | 1,433,110 | 1,433,109 | 1,060,358 |
| Accrued Property Taxes | 135,991 | 124,659 | 85,490 |
| Miscellaneous Accrued Expenses | 632,746 | 639,612 | 565,415 |
| Consumers' Deposits | 987,494 | 997,630 | 977,254 |
| Non-Consumers' Deposits | 270,000 | 270,000 | 270,000 |
| Unearned Revenue | 633,525 | 712,538 | 6,688 |
| Total Current Liabilities | 8,436,148 | 8,238,556 | 7,308,644 |
| Non-Current Liabilities: | | | |
| Health & Dental Insurance Provision | 132,651 | 148,912 | 40,680 |
| Post-Employment Health Benefit Provision | 1,178,825 | 861,443 | 843,413 |
| Landfill Closure and Postclosure Liability | 1,518,755 | 1,475,608 | 1,475,608 |
| Plant Decommissioning | 56,622,579 | 56,622,579 | 12,012,000 |
| Subscription Based IT Arrangements | 1,117,072 | 1,123,842 | 959,058 |
| Net Pension Liability | 3,364,004 | 9,534,547 | 8,299,852 |
| Total Non-Current Liabilities | 63,933,886 | 69,766,931 | 23,630,612 |
| Deferred Inflows of Resources: | | | |
| Extraordinary O&M | 28,032,866 | 28,032,866 | 28,032,866 |
| Pension | 3,163,631 | 3,341,477 | 3,341,477 |
| OPEB | 74,093 | 34,341 | 55,273 |
| IPERS | 25,209 | 25,209 | 25,209 |
| Total Deferred Inflows of Resources | 31,295,799 | 31,433,892 | 31,454,825 |
| Net Position: | | | |
| Net Investment in Capital Assets | 82,278,113 | 81,937,774 | 77,130,140 |
| Unrestricted | 47,881,078 | 49,421,440 | 50,631,582 |
| Total Net Position | 130,159,191 | 131,359,214 | 127,761,722 |
| TOTAL LIABILITIES AND NET POSITION | \$ 233,825,024 | \$ 240,798,592 | \$ 190,155,802 |

Muscatine Power and Water - Electric Utility
Statements of Cash Flows
December 2025

| | <u>Month</u> | <u>Year To Date</u> |
|---|----------------------|----------------------|
| Cash Flows from Operating Activities: | | |
| Operating Margin | \$ (168,031) | \$ 11,879,315 |
| Noncash Items in Operating Margin: | | |
| Amortization of Joint Venture Rights | 10,570 | 85,401 |
| Change in Deferred Inflows of Resources | (138,093) | (159,026) |
| Change in Deferred Outflows of Resources | 5,905,554 | 3,326,625 |
| Changes in Assets and Liabilities: | | |
| Customer Accounts Receivable | 1,550,236 | 126,279 |
| Refined Coal | - | - |
| Wholesale Receivable | 244,332 | (367,099) |
| Steam Sales Receivable | - | - |
| Inventories | (76,717) | 208,978 |
| Fuel | 2,234,050 | 6,851,140 |
| Prepaid Expenses | 238,190 | (257,858) |
| Accounts Payable | 80,811 | (88,480) |
| Net Pension Liability | (6,170,543) | (4,935,848) |
| Landfill Closure And Post Closure Liability | 43,147 | 43,147 |
| Health & Dental Insurance Provision | (76,015) | 32,217 |
| Other Post-Employment Benefit Provision | 317,382 | 335,412 |
| Accrued Payroll | 287,702 | 216,931 |
| Accrued Compensated Absences | (26,487) | (68,856) |
| Accrued Emission Allowance Expense | 1 | 372,752 |
| Consumers' Deposits | (10,136) | 10,241 |
| Accrued Property Taxes | 11,332 | 50,501 |
| Unearned Revenue | (79,013) | 626,838 |
| Special Non-Consumers' Deposits | - | - |
| Miscellaneous Accrued Expenses | (14,502) | (44,922) |
| Net Cash Flows from Operating Activities | 4,163,772 | 18,243,689 |
| Cash Flows From Noncapital Financing Activities: | | |
| Principal Activity With Water Utility | 1,356,044 | 1,490,629 |
| Interest Activity with Water Utility | 30,511 | 64,050 |
| Principal Activity With Comm Utility | 2,609,637 | 2,609,637 |
| Interest Activity With Comm Utility | 6,524 | 13,048 |
| Net Cash Flows From Noncapital Financing Activities: | 4,002,716 | 4,177,365 |
| Cash Flows from Capital & Financing Activities: | | |
| Capital Expenditures | (971,051) | (12,261,862) |
| Gain/(Loss) on Disposal of Assets | 6,581 | 43,905 |
| Net Cash Flows from Capital & Financing Activities | (964,470) | (12,217,957) |
| Cash Flows from Investing Activities: | | |
| Purchase of Joint Venture Rights | - | (93,292) |
| Interest Received on Investments | 271,371 | 2,595,179 |
| Net Cash Flows from Investing Activities | 271,371 | 2,501,887 |
| Net Increase/(Decrease) | 7,473,390 | 12,704,984 |
| Cash and Investments at Beginning of Period | 65,663,183 | 60,431,589 |
| Cash and Investments at End of Period | \$ 73,136,573 | \$ 73,136,573 |

Muscatine Power and Water - Electric Utility
Summary of Expenses
Current Month - December 2025

| Summary of Expenses | Results | | | Variance | | | |
|---|---------------------|---------------------|---------------------|---------------------|---------------|---------------------|---------------|
| | Actual | Budget | Prior Year | Vs Budget \$ | % | Vs Prior Yr \$ | % |
| Purchased Electricity (555) | | | | | | | |
| Purchased Electricity - Energy | \$ 3,303,149 | \$ 2,536,176 | \$ 2,650,747 | (766,973) | -30.2% | (652,402) | -24.6% |
| Purchased Electricity - Demand | 203,195 | 23,618 | 3,571 | (179,577) | -760.3% | (199,624) | NM |
| Total Purchased Electricity | \$ 3,506,344 | \$ 2,559,794 | \$ 2,654,318 | \$ (946,550) | -37.0% | \$ (852,026) | -32.1% |
| <i>% of Operating Revenue</i> | 35.1% | 30.6% | 31.0% | | | | |
| Generation | | | | | | | |
| Fuel: (501) | | | | | | | |
| Coal | 2,241,480 | 1,679,180 | 1,979,146 | (562,300) | -33.5% | (262,334) | -13.3% |
| Fuel Oil | 535 | 250 | 2,928 | (285) | -113.8% | 2,394 | 81.7% |
| Gas | 3,594 | - | 3,718 | (3,594) | -100.0% | 124 | 3.3% |
| Coal Handling Expense (501-003) | 23,373 | 15,088 | 17,874 | (8,284) | -54.9% | (5,498) | -30.8% |
| Landfill Operation Expense (501-925) | 81,791 | 107,446 | 259,513 | 25,655 | 23.9% | 177,722 | 68.5% |
| Emissions Allowance Expense (509) | 1 | - | (895) | (1) | -100.0% | (896) | NM |
| Steam Expense: | | | | | | | |
| Boiler (502-004) | 74,577 | 64,059 | 58,084 | (10,518) | -16.4% | (16,492) | -28.4% |
| Pollution Control (502-005) | 20,644 | 13,128 | 38,145 | (7,516) | -57.3% | 17,501 | 45.9% |
| Electric Expense (505) | 34,074 | 237,818 | 35,338 | 203,743 | 85.7% | 1,263 | 3.6% |
| Miscellaneous Steam Power Expense (506) | 107,248 | 145,234 | 197,054 | 37,987 | 26.2% | 89,806 | 45.6% |
| Maintenance: | | | | | | | |
| Structures (511) | 86,529 | 29,117 | 57,979 | (57,412) | -197.2% | (28,550) | -49.2% |
| Boiler Plant: | | | | | | | |
| Boiler (512-006) | 266,546 | 162,593 | 194,372 | (103,953) | -63.9% | (72,174) | -37.1% |
| Pollution Control (512-007) | 30,817 | 40,436 | 43,876 | 9,618 | 23.8% | 13,058 | 29.8% |
| Electric Plant (513-008) | 32,648 | 125,491 | 18,547 | 92,843 | 74.0% | (14,100) | -76.0% |
| System Control (513-009) | - | 2,000 | 176 | 2,000 | 100.0% | 176 | 100.0% |
| Miscellaneous Steam Plant (514) | 31,705 | 62,594 | 69,710 | 30,889 | 49.3% | 38,006 | 54.5% |
| Coal Handling Equipment (516) | 475,314 | 171,319 | 33,253 | (303,995) | -177.4% | (442,061) | NM |
| System Control and Load Dispatch (556) | 34,555 | 16,130 | 21,025 | (18,425) | -114.2% | (13,530) | -64.3% |
| Generation Labor | 675,274 | 621,498 | 626,663 | (53,776) | -8.7% | (48,612) | -7.8% |
| Total Generation Expense | \$ 4,220,704 | \$ 3,493,381 | \$ 3,656,508 | \$ (727,323) | -20.8% | \$ (564,196) | -15.4% |
| <i>% of Operating Revenue</i> | 42.2% | 41.8% | 42.6% | | | | |

Muscatine Power and Water - Electric Utility
Summary of Expenses
Current Month - December 2025

| Summary of Expenses | Results | | | Variance | | | |
|---|-------------------|-------------------|-------------------|--------------------|---------------|--------------------|---------------|
| | Actual | Budget | Prior Year | Vs Budget \$ | % | Vs Prior Yr \$ | % |
| Transmission | | | | | | | |
| Load Dispatching (561) | \$ 42,150 | \$ 19,176 | \$ 59,221 | \$ (22,974) | -119.8% | \$ 17,070 | 28.8% |
| Station Expense (562) | 1,803 | 608 | 1,342 | (1,194) | -196.4% | (461) | -34.4% |
| Overhead Line Expense (563) | 711 | - | - | (711) | -100.0% | (711) | -100.0% |
| Transmission of Electricity by Others (565) | 138,518 | 149,997 | 137,387 | 11,479 | 7.7% | (1,131) | -0.8% |
| Miscellaneous Transmission Expense (566) | 6,593 | 213,870 | 10,229 | 207,277 | 96.9% | 3,636 | 35.5% |
| Maintenance: | | | | | | | |
| Structures (569) | - | - | - | - | NM | - | NM |
| Station Equipment (570) | 7,508 | 9,935 | 7,315 | 2,427 | 24.4% | (193) | -2.6% |
| Overhead Lines (571) | (18,927) | 1,000 | 43,434 | 19,927 | NM | 62,361 | NM |
| Tax on Rural Property (577) | 8,157 | 11,614 | 5,085 | 3,457 | 29.8% | (3,072) | -60.4% |
| Transmission Labor | 122,502 | 100,034 | 101,820 | (22,467) | -22.5% | (20,682) | -20.3% |
| Total Transmission Expense | 309,014 | 506,235 | 365,832 | 197,220 | 39.0% | 56,817 | 15.5% |
| <i>% of Operating Revenue</i> | 3.1% | 6.1% | 4.3% | | | | |
| Distribution | | | | | | | |
| Load Dispatching (581) | 4,201 | 3,803 | 4,201 | (397) | -10.4% | - | 0.0% |
| Station Expense (582) | 6,346 | 3,629 | 7,950 | (2,717) | -74.9% | 1,603 | 20.2% |
| Overhead Line Expense (583) | 1,786 | 2,767 | 740 | 981 | 35.5% | (1,046) | -141.2% |
| Vehicle Expense (589) | 3,588 | 14,191 | 7,091 | 10,603 | 74.7% | 3,503 | 49.4% |
| Underground Line Expense (584) | 332 | 725 | 901 | 393 | 54.2% | 570 | 63.2% |
| Street Lighting (585-418) | 24 | 250 | (108) | 226 | 90.5% | (131) | NM |
| Signal Expense (585-419) | 2,281 | 150 | 2,997 | (2,131) | NM | 715 | 23.9% |
| Meter Expense (586) | 3,239 | 1,550 | 5,177 | (1,689) | -108.9% | 1,939 | 37.4% |
| Consumer Installation Expense (587) | - | - | - | - | NM | - | NM |
| Miscellaneous Distribution Expense (588) | 43,205 | 21,762 | 31,915 | (21,443) | -98.5% | (11,290) | -35.4% |
| Maintenance: | | | | | | | |
| Structures (591) | - | 1,265 | - | 1,265 | 100.0% | - | NM |
| Station Equipment (592) | 3,154 | 9,129 | 7,193 | 5,975 | 65.4% | 4,038 | 56.1% |
| Overhead Lines (593) | 36,826 | 13,443 | 9,781 | (23,383) | -173.9% | (27,045) | -276.5% |
| Underground Lines (594) | 10,260 | 25 | 20,915 | (10,235) | NM | 10,655 | 50.9% |
| Line Transformers (595) | - | 25 | - | 25 | 100.0% | - | NM |
| Street Lighting (596-418) | 3,883 | 1,500 | (1,413) | (2,383) | -158.9% | (5,296) | NM |
| Signal System (596-419) | - | 1,667 | 648 | 1,667 | 100.0% | 648 | 100.0% |
| Meters (597) | - | 50 | - | 50 | 100.0% | - | NM |
| Miscellaneous Distribution Plant (598) | 6,147 | 5,888 | 7,296 | (260) | -4.4% | 1,149 | 15.7% |
| Tax on Rural Property (579) | 2,635 | 2,044 | 1,519 | (591) | -28.9% | (1,116) | -73.5% |
| Distribution Labor | 354,661 | 315,670 | 303,059 | (38,992) | -12.4% | (51,602) | -17.0% |
| Total Distribution Expense | \$ 482,568 | \$ 399,532 | \$ 409,862 | \$ (83,035) | -20.8% | \$ (72,706) | -17.7% |
| <i>% of Operating Revenue</i> | 4.8% | 4.8% | 4.8% | | | | |

Muscatine Power and Water - Electric Utility
Summary of Expenses
Current Month - December 2025

| Summary of Expenses | Results | | | Variance | | | |
|---|----------------------|---------------------|---------------------|-----------------------|---------------|-----------------------|----------------|
| | Actual | Budget | Prior Year | Vs Budget \$ | % | Vs Prior Yr \$ | % |
| Customer Service Expense | | | | | | | |
| Customer Information Expense (909) | \$ 5,520 | \$ 7,040 | \$ 1,529 | \$ 1,520 | 21.6% | \$ (3,991) | -261.0% |
| Energy Efficiency Rebates (912) | 350 | 5,858 | 1,220 | 5,508 | 94.0% | 870 | 71.3% |
| Electric Ranges/Dryers Maintenance (910) | (1) | - | (2) | 1 | NM | (1) | -47.3% |
| Electric Water Heaters Maintenance (911) | - | - | - | - | NM | - | NM |
| Total Customer Service Expense | 5,868 | 12,898 | 2,746 | 7,030 | 54.5% | (3,122) | -113.7% |
| <i>% of Operating Revenue</i> | <i>0.1%</i> | <i>0.2%</i> | <i>0.0%</i> | | | | |
| Consumer Accounts | | | | | | | |
| Meter Reading Expense (902) | 249 | 480 | 377 | 230 | 48.1% | 128 | 34.0% |
| Consumer Records and Collection (901/903) | 20,061 | 13,611 | 11,255 | (6,451) | -47.4% | (8,806) | -78.2% |
| Uncollectible Accounts Expense (904) | (14,464) | 5,331 | 21,154 | 19,795 | NM | 35,617 | NM |
| Total Consumer Accounts Expense | 5,847 | 19,421 | 32,786 | 13,575 | 69.9% | 26,939 | 82.2% |
| <i>% of Operating Revenue</i> | <i>0.1%</i> | <i>0.2%</i> | <i>0.4%</i> | | | | |
| Administrative and General | | | | | | | |
| Office Supplies and Expenses (921) | 62,177 | 22,931 | (1,841) | (39,246) | -171.2% | (64,018) | NM |
| Outside Services Employed (923) | 91,050 | 294,677 | 111,802 | 203,627 | 69.1% | 20,751 | 18.6% |
| Property Insurance (924) | 123,341 | 123,813 | 120,181 | 472 | 0.4% | (3,160) | -2.6% |
| Casualty Ins, Injuries & Damages (925) | 47,056 | 69,192 | 83,867 | 22,136 | 32.0% | 36,811 | 43.9% |
| Employee Benefits (926) | 449,448 | 394,131 | (285,257) | (55,317) | -14.0% | (734,705) | NM |
| Employee Pensions (926-PEN) | 97,144 | 180,200 | 122,156 | 83,056 | 46.1% | 25,012 | 20.5% |
| Fringe Benefits Charged to Constr. (927) | (25,093) | (35,417) | (22,615) | (10,324) | -29.1% | 2,478 | 11.0% |
| Regulatory Commission (928) | 22,426 | 8,782 | 3,133 | (13,644) | -155.4% | (19,293) | -615.8% |
| Miscellaneous General Expense (930) | 78,226 | 64,219 | 38,683 | (14,008) | -21.8% | (39,543) | -102.2% |
| A&G Adder (930-AGA) | 75,607 | (160,802) | (5,489) | (236,409) | NM | (81,096) | NM |
| Maintenance of General Plant (932) | 87,867 | 122,033 | 100,164 | 34,166 | 28.0% | 12,297 | 12.3% |
| Maintenance of A/O Center (934) | 53,991 | 22,250 | 45,637 | (31,741) | -142.7% | (8,355) | -18.3% |
| Administrative and General Labor | 471,658 | 403,405 | 434,342 | (68,253) | -16.9% | (37,316) | -8.6% |
| Total Administrative and General | 1,634,899 | 1,509,414 | 744,763 | (125,486) | -8.3% | (890,137) | -119.5% |
| <i>% of Operating Revenue</i> | <i>16.4%</i> | <i>18.0%</i> | <i>8.7%</i> | | | | |
| TOTAL OPERATING EXPENSES | \$ 10,165,245 | \$ 8,500,675 | \$ 7,866,815 | \$ (1,664,570) | -19.6% | \$ (2,298,430) | -29.2% |
| <i>% of Operating Revenue</i> | <i>101.7%</i> | <i>101.6%</i> | <i>91.8%</i> | | | | |
| Depreciation | | | | | | | |
| Generation Depreciation (558) | 358,846 | 401,865 | 380,812 | 43,019 | 10.7% | 21,966 | 5.8% |
| Plant Decommissioning Depreciation (407) | 681,931 | 132,796 | 132,796 | (549,135) | -413.5% | (549,135) | -413.5% |
| Transmission Depreciation (576) | 86,798 | 85,190 | 84,279 | (1,608) | -1.9% | (2,519) | -3.0% |
| Distribution Depreciation (578) | 89,136 | 72,725 | 75,439 | (16,412) | -22.6% | (13,697) | -18.2% |
| A&G Depreciation (933) | 79,646 | 54,205 | 66,638 | (25,442) | -46.9% | (13,008) | -19.5% |
| Subscription-Based IT Arrangements (428) | 36,794 | 12,422 | 25,341 | (24,372) | -196.2% | (11,454) | -45.2% |
| Total Depreciation | \$ 1,333,152 | \$ 759,203 | \$ 765,305 | \$ (573,950) | -75.6% | \$ (567,848) | -74.2% |
| <i>% of Operating Revenue</i> | <i>13.3%</i> | <i>9.1%</i> | <i>8.9%</i> | | | | |

Muscatine Power and Water - Electric Utility
Summary of Expenses
Year To Date - December 2025

| Summary of Expenses | Results | | | Variance | | | |
|---|----------------------|----------------------|----------------------|-----------------------|---------------|------------------------|---------------|
| | Actual | Budget | Prior Year | Vs Budget \$ | % | Vs Prior Yr \$ | % |
| Purchased Electricity (555) | | | | | | | |
| Purchased Electricity - Energy | \$ 37,029,648 | \$ 32,455,271 | \$ 27,041,018 | (4,574,377) | -14.1% | (9,988,630) | -36.9% |
| Purchased Electricity - Demand | 8,185,711 | 3,119,494 | 790,763 | (5,066,216) | -162.4% | (7,394,947) | -935.2% |
| Total Purchased Electricity | \$ 45,215,359 | \$ 35,574,765 | \$ 27,831,781 | \$ (9,640,594) | -27.1% | \$ (17,383,578) | -62.5% |
| % of Operating Revenue | 37.3% | 34.6% | 30.6% | | | | |
| Generation | | | | | | | |
| Fuel: (501) | | | | | | | |
| Coal | 20,374,026 | 17,031,210 | 15,219,179 | (3,342,816) | -19.6% | (5,154,847) | -33.9% |
| Fuel Oil | 182,406 | 253,000 | 88,281 | 70,594 | 27.9% | (94,125) | -106.6% |
| Gas | 110,993 | 120,000 | 89,571 | 9,007 | 7.5% | (21,422) | -23.9% |
| Coal Handling Expense (501-003) | 198,696 | 181,440 | 192,328 | (17,256) | -9.5% | (6,368) | -3.3% |
| Landfill Operation Expense (501-925) | 179,515 | 442,167 | 318,528 | 262,652 | 59.4% | 139,012 | 43.6% |
| Emissions Allowance Expense (509) | 372,752 | - | 407,809 | (372,752) | -100.0% | 35,057 | 8.6% |
| Steam Expense: | | | | | | | |
| Boiler (502-004) | 495,317 | 531,900 | 465,648 | 36,583 | 6.9% | (29,669) | -6.4% |
| Pollution Control (502-005) | 317,780 | 277,400 | 272,376 | (40,379) | -14.6% | (45,403) | -16.7% |
| Electric Expense (505) | 448,187 | 412,740 | 404,487 | (35,448) | -8.6% | (43,700) | -10.8% |
| Miscellaneous Steam Power Expense (506) | 1,547,602 | 1,927,039 | 1,476,779 | 379,437 | 19.7% | (70,823) | -4.8% |
| Maintenance: | | | | | | | |
| Structures (511) | 589,231 | 392,810 | 1,084,102 | (196,420) | -50.0% | 494,872 | 45.6% |
| Boiler Plant: | | | | | | | |
| Boiler (512-006) | 2,404,012 | 2,269,081 | 3,871,951 | (134,930) | -5.9% | 1,467,940 | 37.9% |
| Pollution Control (512-007) | 687,929 | 618,480 | 861,757 | (69,449) | -11.2% | 173,828 | 20.2% |
| Electric Plant (513-008) | 837,060 | 836,502 | 614,811 | (558) | -0.1% | (222,249) | -36.1% |
| System Control (513-009) | 358 | 2,000 | 176 | 1,642 | 82.1% | (182) | -103.2% |
| Miscellaneous Steam Plant (514) | 613,132 | 753,680 | 814,918 | 140,548 | 18.6% | 201,786 | 24.8% |
| Coal Handling Equipment (516) | 1,210,433 | 763,381 | 451,654 | (447,052) | -58.6% | (758,779) | -168.0% |
| System Control and Load Dispatch (556) | 225,046 | 190,077 | 194,150 | (34,969) | -18.4% | (30,896) | -15.9% |
| Generation Labor | 8,726,948 | 7,809,651 | 8,226,701 | (917,297) | -11.7% | (500,247) | -6.1% |
| Total Generation Expense | \$ 39,521,421 | \$ 34,812,558 | \$ 35,055,207 | \$ (4,708,862) | -13.5% | \$ (4,466,214) | -12.7% |
| % of Operating Revenue | 32.6% | 33.9% | 38.5% | | | | |

Muscatine Power and Water - Electric Utility
Summary of Expenses
Year To Date - December 2025

| Summary of Expenses | Results | | | Variance | | | |
|---|---------------------|---------------------|---------------------|---------------------|--------------|---------------------|---------------|
| | Actual | Budget | Prior Year | Vs Budget \$ | % | Vs Prior Yr \$ | % |
| Transmission | | | | | | | |
| Load Dispatching (561) | \$ 549,054 | \$ 327,912 | \$ 528,182 | \$ (221,141) | -67.4% | \$ (20,872) | -4.0% |
| Station Expense (562) | 32,091 | 19,560 | 29,698 | (12,531) | -64.1% | (2,393) | -8.1% |
| Overhead Line Expense (563) | 711 | - | 260 | - | -100.0% | (451) | -173.4% |
| Transmission of Electricity by Others (565) | 1,932,578 | 1,799,962 | 1,717,089 | (132,616) | -7.4% | (215,489) | -12.5% |
| Miscellaneous Transmission Expense (566) | 133,895 | 614,582 | 33,038 | 480,687 | 78.2% | (100,856) | -305.3% |
| Maintenance: | | | | | | | |
| Structures (569) | - | - | - | - | NM | - | NM |
| Station Equipment (570) | 45,667 | 119,739 | 99,696 | 74,072 | 61.9% | 54,029 | 54.2% |
| Overhead Lines (571) | 33,798 | 84,000 | 60,153 | 50,202 | 59.8% | 26,355 | 43.8% |
| Tax on Rural Property (577) | 116,564 | 139,364 | 60,289 | 22,800 | 16.4% | (56,275) | -93.3% |
| Transmission Labor | 1,420,745 | 1,184,192 | 1,215,400 | (236,553) | -20.0% | (205,345) | -16.9% |
| Total Transmission Expense | 4,265,102 | 4,289,310 | 3,743,805 | 24,209 | 0.6% | (521,297) | -13.9% |
| % of Operating Revenue | 3.5% | 4.2% | 4.1% | | | | |
| Distribution | | | | | | | |
| Load Dispatching (581) | 50,822 | 45,641 | 49,725 | (5,182) | -11.4% | (1,098) | -2.2% |
| Station Expense (582) | 68,932 | 51,337 | 85,136 | (17,595) | -34.3% | 16,205 | 19.0% |
| Overhead Line Expense (583) | 34,142 | 33,204 | 26,261 | (938) | -2.8% | (7,881) | -30.0% |
| Vehicle Expense (589) | 82,042 | 152,264 | 89,894 | 70,222 | 46.1% | 7,852 | 8.7% |
| Underground Line Expense (584) | 10,683 | 20,700 | 15,187 | 10,017 | 48.4% | 4,504 | 29.7% |
| Street Lighting (585-418) | 6,562 | 3,000 | 3,331 | (3,562) | -118.7% | (3,232) | -97.0% |
| Signal Expense (585-419) | 8,059 | 3,753 | 4,768 | (4,306) | -114.7% | (3,291) | -69.0% |
| Meter Expense (586) | 32,446 | 27,406 | 30,130 | (5,040) | -18.4% | (2,316) | -7.7% |
| Consumer Installation Expense (587) | - | - | 1,023 | - | NM | 1,023 | 100.0% |
| Miscellaneous Distribution Expense (588) | 372,026 | 392,703 | 346,649 | 20,677 | 5.3% | (25,376) | -7.3% |
| Maintenance: | | | | | | | |
| Structures (591) | - | 5,790 | - | 5,790 | 100.0% | - | NM |
| Station Equipment (592) | 29,221 | 110,059 | 72,961 | 80,838 | 73.4% | 43,740 | 59.9% |
| Overhead Lines (593) | 347,678 | 196,316 | 290,475 | (151,362) | -77.1% | (57,203) | -19.7% |
| Underground Lines (594) | 186,791 | 75,300 | 196,916 | (111,491) | -148.1% | 10,125 | 5.1% |
| Line Transformers (595) | 105,839 | 35,300 | 2,398 | (70,539) | -199.8% | (103,441) | NM |
| Street Lighting (596-418) | 56,230 | 47,000 | 60,456 | (9,230) | -19.6% | 4,226 | 7.0% |
| Signal System (596-419) | 33,506 | 20,000 | 33,618 | (13,506) | -67.5% | 111 | 0.3% |
| Meters (597) | 2,244 | 1,600 | 2,777 | (644) | -40.3% | 533 | 19.2% |
| Miscellaneous Distribution Plant (598) | 75,119 | 67,550 | 116,335 | (7,569) | -11.2% | 41,216 | 35.4% |
| Tax on Rural Property (579) | 38,391 | 24,528 | 18,009 | (13,863) | -56.5% | (20,382) | -113.2% |
| Distribution Labor | 3,872,005 | 3,738,204 | 3,521,053 | (133,801) | -3.6% | (350,952) | -10.0% |
| Total Distribution Expense | \$ 5,412,737 | \$ 5,051,654 | \$ 4,967,101 | \$ (361,083) | -7.1% | \$ (445,636) | -9.0% |
| % of Operating Revenue | 4.5% | 4.9% | 5.5% | | | | |

Muscatine Power and Water - Electric Utility
Summary of Expenses
Year To Date - December 2025

| Summary of Expenses | Results | | | Variance | | | |
|---|-----------------------|----------------------|----------------------|------------------------|---------------|------------------------|---------------|
| | Actual | Budget | Prior Year | Vs Budget \$ | % | Vs Prior Yr \$ | % |
| Customer Service Expense | | | | | | | |
| Customer Information Expense (909) | \$ 90,203 | \$ 121,979 | \$ 52,738 | \$ 31,777 | 26.1% | \$ (37,465) | -71.0% |
| Energy Efficiency Rebates (912) | 20,530 | 72,796 | 21,812 | 52,266 | 71.8% | 1,283 | 5.9% |
| Electric Ranges/Dryers Maintenance (910) | (19) | - | 220 | 19 | NM | 239 | NM |
| Electric Water Heaters Maintenance (911) | - | - | - | - | NM | - | NM |
| Total Customer Service Expense | 110,713 | 194,775 | 74,770 | 84,062 | 43.2% | (35,943) | -48.1% |
| % of Operating Revenue | 0.1% | 0.2% | 0.1% | | | | |
| Consumer Accounts | | | | | | | |
| Meter Reading Expense (902) | 5,870 | 5,755 | 22,780 | (115) | -2.0% | 16,910 | 74.2% |
| Consumer Records and Collection (901/903) | 137,586 | 162,506 | 155,972 | 24,921 | 15.3% | 18,387 | 11.8% |
| Uncollectible Accounts Expense (904) | 100,029 | 63,973 | 90,759 | (36,056) | -56.4% | (9,270) | -10.2% |
| Total Consumer Accounts Expense | 243,485 | 232,234 | 269,511 | (11,251) | -4.8% | 26,026 | 9.7% |
| % of Operating Revenue | 0.2% | 0.2% | 0.3% | | | | |
| Administrative and General | | | | | | | |
| Office Supplies and Expenses (921) | 270,812 | 196,146 | 191,386 | (74,666) | -38.1% | (79,426) | -41.5% |
| Outside Services Employed (923) | 776,614 | 1,536,418 | 641,451 | 759,804 | 49.5% | (135,164) | -21.1% |
| Property Insurance (924) | 1,111,576 | 1,105,683 | 1,146,417 | (5,893) | -0.5% | 34,840 | 3.0% |
| Casualty Ins, Injuries & Damages (925) | 731,971 | 804,744 | 776,198 | 72,773 | 9.0% | 44,228 | 5.7% |
| Employee Benefits (926) | 4,811,284 | 4,763,416 | 3,885,121 | (47,869) | -1.0% | (926,164) | -23.8% |
| Employee Pensions (926-PEN) | 1,331,839 | 2,162,394 | 1,798,583 | 830,555 | 38.4% | 466,744 | 26.0% |
| Fringe Benefits Charged to Constr. (927) | (283,676) | (425,000) | (332,351) | (141,324) | -33.3% | (48,676) | -14.6% |
| Regulatory Commission (928) | 138,020 | 105,388 | 116,016 | (32,632) | -31.0% | (22,004) | -19.0% |
| Miscellaneous General Expense (930) | 635,743 | 749,848 | 550,524 | 114,104 | 15.2% | (85,219) | -15.5% |
| A&G Adder (930-AGA) | (1,394,265) | (1,929,628) | (209,147) | (535,362) | -27.7% | 1,185,118 | 566.6% |
| Maintenance of General Plant (932) | 777,301 | 984,365 | 795,060 | 207,063 | 21.0% | 17,759 | 2.2% |
| Maintenance of A/O Center (934) | 606,074 | 385,015 | 496,603 | (221,059) | -57.4% | (109,471) | -22.0% |
| Administrative and General Labor | 4,980,140 | 4,747,703 | 4,865,525 | (232,437) | -4.9% | (114,615) | -2.4% |
| Total Administrative and General | 14,493,434 | 15,186,491 | 14,721,386 | 693,058 | 4.6% | 227,952 | 1.5% |
| % of Operating Revenue | 12.0% | 14.8% | 16.2% | | | | |
| TOTAL OPERATING EXPENSES | \$ 109,262,251 | \$ 95,341,790 | \$ 86,663,561 | \$ (13,920,461) | -14.6% | \$ (22,598,689) | -26.1% |
| % of Operating Revenue | 90.2% | 92.8% | 95.2% | | | | |
| Depreciation | | | | | | | |
| Generation Depreciation (558) | 4,299,516 | 4,822,385 | 4,238,935 | 522,869 | 10.8% | (60,581) | -1.4% |
| Plant Decommissioning Depreciation (407) | 4,888,358 | 1,593,548 | 1,593,548 | (3,294,810) | -206.8% | (3,294,810) | -206.8% |
| Transmission Depreciation (576) | 1,036,543 | 1,022,279 | 1,011,407 | (14,264) | -1.4% | (25,136) | -2.5% |
| Distribution Depreciation (578) | 981,703 | 872,698 | 853,329 | (109,005) | -12.5% | (128,374) | -15.0% |
| A&G Depreciation (933) | 829,965 | 650,456 | 771,429 | (179,509) | -27.6% | (58,535) | -7.6% |
| Subscription-Based IT Arrangements (428) | 392,369 | 149,029 | 211,491 | (243,340) | -163.3% | (180,878) | -85.5% |
| Total Depreciation | \$ 12,428,454 | \$ 9,110,394 | \$ 8,680,139 | \$ (3,318,059) | -36.4% | \$ (3,748,315) | -43.2% |
| % of Operating Revenue | 10.3% | 8.9% | 9.5% | | | | |

**Muscatine Power and Water - Electric Utility
Rates
December 2025**

Current Month

| Retail Sales | | Results | | | Variance | | | |
|---------------------------|-------|---------|--------------|--------------|--------------|----------------|---------------|--------------|
| | UOM | Actual | Budget | Prior Year | Vs Budget ¢ | % | Vs Prior Yr ¢ | % |
| Residential | ¢/kWh | 13.362 | 13.644 | 12.782 | (0.282) | -2.1% | 0.580 | 4.5% |
| Commercial I | | 12.272 | 12.953 | 12.151 | (0.681) | -5.3% | 0.122 | 1.0% |
| Commercial II | | 9.187 | 8.876 | 9.331 | 0.311 | 3.5% | (0.144) | -1.5% |
| Industrial I | | 7.623 | 7.745 | 7.758 | (0.122) | -1.6% | (0.135) | -1.7% |
| Industrial II | | 6.103 | 6.364 | 6.117 | (0.262) | -4.1% | (0.015) | -0.2% |
| City Enterprise Funds | | 9.146 | 8.491 | 8.671 | 0.655 | 7.7% | 0.476 | 5.5% |
| Inter-Utility | | 8.121 | 7.908 | 7.396 | 0.213 | 2.7% | 0.725 | 9.8% |
| Total Retail Sales | | ¢/kWh | 7.706 | 7.856 | 7.657 | (0.150) | -1.9% | 0.049 |

Year To Date

| Retail Sales | | Results | | | Variance | | | |
|---------------------------|-------|---------|--------------|--------------|--------------|----------------|---------------|--------------|
| | UOM | Actual | Budget | Prior Year | Vs Budget ¢ | % | Vs Prior Yr ¢ | % |
| Residential | ¢/kWh | 12.893 | 13.064 | 12.632 | (0.170) | -1.3% | 0.261 | 2.1% |
| Commercial I | | 12.286 | 12.507 | 12.030 | (0.221) | -1.8% | 0.256 | 2.1% |
| Commercial II | | 9.382 | 8.770 | 9.274 | 0.612 | 7.0% | 0.107 | 1.2% |
| Industrial I | | 7.447 | 7.612 | 7.318 | (0.164) | -2.2% | 0.129 | 1.8% |
| Industrial II | | 6.232 | 6.313 | 6.115 | (0.081) | -1.3% | 0.117 | 1.9% |
| City Enterprise Funds | | 9.479 | 8.394 | 8.870 | 1.085 | 12.9% | 0.609 | 6.9% |
| Inter-Utility | | 7.569 | 7.775 | 7.335 | (0.206) | -2.6% | 0.235 | 3.2% |
| Total Retail Sales | | ¢/kWh | 7.804 | 7.809 | 7.628 | (0.005) | -0.1% | 0.176 |

Energy Adjustment Clause Rates

| | | Results | | | Variance | | | |
|---------------|-------|----------|----------|------------|-------------|----------|---------------|---------|
| | UOM | Actual | Budget | Prior Year | Vs Budget ¢ | % | Vs Prior Yr ¢ | % |
| January | ¢/kWh | 0.2409 | 0.3618 | 0.3034 | (0.121) | -33.4% | (0.062) | -20.6% |
| February | | 0.3033 | 0.4119 | 0.3049 | (0.109) | -26.4% | (0.002) | -0.5% |
| March | | 0.3333 | 0.4114 | 0.2563 | (0.078) | -19.0% | 0.077 | 30.0% |
| April | | 0.3358 | 0.3715 | 0.2836 | (0.036) | -9.6% | 0.052 | 18.4% |
| May | | 0.3438 | 0.3950 | 0.2691 | (0.051) | -13.0% | 0.075 | 27.8% |
| June | | 0.3047 | 0.2887 | 0.0990 | 0.016 | 5.6% | 0.206 | 207.9% |
| July | | - | - | 0.0959 | - | NM | (0.096) | -100.0% |
| August | | - | - | 0.0826 | - | NM | (0.083) | -100.0% |
| September | | (0.2643) | - | 0.0884 | (0.264) | NM | (0.353) | -398.9% |
| October | | (0.2438) | 0.0096 | 0.0748 | (0.253) | -2637.8% | (0.319) | -426.1% |
| November | | (0.3521) | 0.0172 | 0.1213 | (0.369) | -2149.1% | (0.473) | -390.4% |
| December | | (0.2573) | 0.1101 | 0.2157 | (0.367) | -333.8% | (0.473) | -219.3% |
| January 2026 | | (0.3176) | (0.1391) | 0.2409 | (0.179) | NM | (0.559) | -231.8% |
| February 2026 | | (0.3038) | (0.0725) | 0.3033 | (0.231) | NM | (0.607) | -200.2% |

Reflecting when rates are effective; based on rolling six-month costs from two months prior

Muscatine Power and Water - Electric Utility
Statistical Data
December 2025

Current Month

| | 2025 | Prior Year | Vs Prior Year % |
|---------------------------------------|-----------|------------|-----------------|
| Total Fuel Cost Per Million Btu | \$2.44 | \$2.76 | -11.6% |
| Coal Burn Cost Per Million Btu | \$2.30 | \$2.40 | -4.0% |
| Total Fuel Cost Per Net MWh Generated | \$27.51 | \$30.75 | -10.5% |
| Coal Burn Cost Per Net MWh Generated | \$26.03 | \$26.76 | -2.7% |
| Net Peak Monthly Demand-kW | 116,680 | 121,650 | -4.1% |
| Date of Peak | 12/4/2025 | 12/12/2024 | |
| Hour of Peak | 10:00 | 12:00 | |

| Average Month Temperature | 2025 | Prior Year |
|--|-------|------------|
| Average Temperature for Muscatine - December | 25.3° | 31.0° |

| Services | 2025 | Prior Year | Vs Prior Year % |
|-----------------------|---------------|---------------|-----------------|
| Residential | 10,105 | 10,123 | -0.2% |
| Commercial I | 1,381 | 1,369 | 0.9% |
| Commercial II | 164 | 156 | 5.1% |
| Industrial I | 14 | 14 | 0.0% |
| Industrial II | 2 | 2 | 0.0% |
| City Enterprise Funds | 26 | 26 | 0.0% |
| Inter-Utility | 35 | 34 | 2.9% |
| Total | 11,727 | 11,724 | 0.0% |

Year To Date

| | 2025 | Prior Year | Vs Prior Year % |
|---------------------------------------|-----------|------------|-----------------|
| Total Fuel Cost Per Million Btu | \$2.41 | \$2.47 | -2.4% |
| Coal Burn Cost Per Million Btu | \$2.32 | \$2.34 | -1.2% |
| Total Fuel Cost Per Net MWh Generated | \$28.03 | \$28.54 | -1.8% |
| Coal Burn Cost Per Net MWh Generated | \$26.93 | \$27.09 | -0.6% |
| Net Peak Monthly Demand-kW | 142,710 | 141,270 | 1.0% |
| Date of Peak | 6/23/2025 | 8/5/2024 | |
| Hour of Peak | 16:00 | 15:00 | |

Record

| | |
|----------------------------|---------|
| Net Peak Monthly Demand-kW | 149,900 |
| Date of Peak | 7/29/99 |
| Hour of Peak | 16:00 |

Muscatine Power and Water - Electric Utility
Wholesale Margins Analysis - Excluding Wind
December 2025

Current Month

| | Actual | \$/MWh | Budget | \$/MWh | Prior Year | \$/MWh |
|---|---------------------|-----------------|---------------------|-----------------|---------------------|-----------------|
| Wholesale MWh Sales | 86,026 | | 62,163 | | 74,097 | |
| Wholesale Sales | | | | | | |
| Wholesale Sales - Energy | \$ 3,940,492 | \$ 45.81 | \$ 2,317,996 | \$ 37.29 | \$ 2,770,462 | \$ 37.39 |
| Wholesale Sales - Capacity | 324,942 | | 32,984 | | 3,408 | |
| Total Wholesale Sales | \$ 4,265,434 | \$ 49.58 | \$ 2,350,980 | \$ 37.82 | \$ 2,773,870 | \$ 37.44 |
| Variable Costs | | | | | | |
| Fuel (Coal, Gas, Fuel Oil) | 2,242,994 | \$ 26.07 | 1,678,539 | \$ 27.00 | 1,989,553 | \$ 26.85 |
| Emissions Allow. (NO _x , SO ₂) | 1 | 0.00 | - | - | (895) | (0.01) |
| Total Variable Costs | \$ 2,242,995 | \$ 26.07 | \$ 1,678,539 | \$ 27.00 | \$ 1,988,658 | \$ 26.84 |
| Gross Margin | \$ 2,022,439 | \$ 23.51 | \$ 672,442 | \$ 10.82 | \$ 785,212 | \$ 10.60 |

| | Actual | \$/MWh | Budget | \$/MWh | Prior Year | \$/MWh |
|----------------------------------|---------------------|-----------------|---------------------|-----------------|---------------------|-----------------|
| Wholesale MWh Purchases | 75,687 | | 78,058 | | 76,363 | |
| Wholesale Purchases | | | | | | |
| Energy | \$ 3,133,156 | \$ 41.40 | \$ 2,391,897 | \$ 30.64 | \$ 2,515,639 | \$ 32.94 |
| Demand | 203,195 | | 23,618 | | 3,571 | |
| Total Wholesale Purchases | \$ 3,336,352 | \$ 44.08 | \$ 2,415,515 | \$ 30.95 | \$ 2,519,210 | \$ 32.99 |

Year To Date

| | Actual | \$/MWh | Budget | \$/MWh | Prior Year | \$/MWh |
|---|----------------------|-----------------|----------------------|-----------------|----------------------|-----------------|
| Wholesale MWh Sales | 754,737 | | 623,804 | | 560,636 | |
| Wholesale Sales | | | | | | |
| Wholesale Sales - Energy | \$ 37,039,414 | \$ 49.08 | \$ 25,670,491 | \$ 41.15 | \$ 20,434,816 | \$ 36.45 |
| Wholesale Sales - Capacity | 11,750,635 | | 4,627,196 | | 1,144,490 | |
| Total Wholesale Sales | \$ 48,790,049 | \$ 64.65 | \$ 30,297,688 | \$ 48.57 | \$ 21,579,305 | \$ 38.49 |
| Variable Costs | | | | | | |
| Fuel (Coal, Gas, Fuel Oil) | 20,616,453 | \$ 27.32 | 17,365,960 | \$ 27.84 | 15,364,235 | \$ 27.40 |
| Emissions Allow. (NO _x , SO ₂) | 372,752 | 0.49 | - | - | 407,809 | 0.73 |
| Total Variable Costs | \$ 20,989,205 | \$ 27.81 | \$ 17,365,960 | \$ 27.84 | \$ 15,772,045 | \$ 28.13 |
| Gross Margin | \$ 27,800,843 | \$ 36.84 | \$ 12,931,728 | \$ 20.73 | \$ 5,807,261 | \$ 10.36 |

| | Actual | \$/MWh | Budget | \$/MWh | Prior Year | \$/MWh |
|----------------------------------|----------------------|-----------------|----------------------|-----------------|----------------------|-----------------|
| Wholesale MWh Purchases | 914,141 | | 934,501 | | 916,396 | |
| Wholesale Purchases | | | | | | |
| Energy | \$ 35,322,634 | \$ 38.64 | \$ 30,894,049 | \$ 33.06 | \$ 25,360,857 | \$ 27.67 |
| Demand | 8,185,711 | | 3,119,494 | | 790,763 | |
| Total Wholesale Purchases | \$ 43,508,345 | \$ 47.59 | \$ 34,013,543 | \$ 36.40 | \$ 26,151,620 | \$ 28.54 |

Muscatine Power and Water - Electric Utility
Wind Margins Analysis
December 2025

Current Month

| | Actual | \$/MWh | Budget | \$/MWh | Prior Year | \$/MWh |
|-------------------------------|--------------------|-----------------|--------------------|-----------------|---------------------|------------------|
| Revenue | | | | | | |
| Wholesale Sales - MWh | 5,419 | | 4,662 | | 4,209 | |
| Wholesale Sales - Energy | \$ 82,917 | \$ 15.30 | \$ 59,114 | \$ 12.68 | \$ (2,507) | \$ (0.60) |
| Wholesale Sales - Capacity | 4,630 | | 1,426 | | 163 | |
| Total Wholesale Sales | \$ 87,547 | \$ 16.15 | \$ 60,540 | \$ 12.98 | \$ (2,344) | \$ (0.56) |
| Expense | | | | | | |
| Purchased Electricity - MWh | 5,419 | | 4,662 | | 4,209 | |
| Purchased Electricity | \$ 169,993 | 31.37 | \$ 144,279 | 30.95 | \$ 135,108 | 32.10 |
| Gross Margin/(Loss) | \$ (82,446) | (15.21) | \$ (83,739) | (17.96) | \$ (137,452) | (32.65) |
| RECs Sold | 3,028 | | - | | 4,112 | |
| REC Net Proceeds | \$ 8,448 | 2.79 | \$ 12,403 | - | \$ 11,472 | 2.79 |
| Wind Net Margin/(Loss) | \$ (73,998) | | \$ (71,336) | | \$ (125,980) | |

Year To Date

| | Actual | \$/MWh | Budget | \$/MWh | Prior Year | \$/MWh |
|-------------------------------|---------------------|-----------------|---------------------|-----------------|-----------------------|----------------|
| Revenue | | | | | | |
| Wholesale Sales - MWh | 54,468 | | 50,452 | | 52,319 | |
| Wholesale Sales - Energy | \$ 637,106 | \$ 11.70 | \$ 549,588 | \$ 10.89 | \$ 93,741 | \$ 1.79 |
| Wholesale Sales - Capacity | 230,465 | | 69,394 | | 17,856 | |
| Total Wholesale Sales | \$ 867,572 | \$ 15.93 | \$ 618,982 | \$ 12.27 | \$ 111,597 | \$ 2.13 |
| Expense | | | | | | |
| Purchased Electricity - MWh | 54,468 | | 50,452 | | 52,319 | |
| Purchased Electricity | \$ 1,707,014 | 31.34 | \$ 1,561,222 | 30.95 | \$ 1,680,161 | 32.11 |
| Gross Margin/(Loss) | \$ (839,442) | (15.41) | \$ (942,240) | (18.68) | \$ (1,568,564) | (29.98) |
| RECs Sold | 50,706 | | - | | 46,098 | |
| REC Net Proceeds | \$ 141,470 | 2.79 | \$ 148,836 | - | \$ 128,612 | 2.79 |
| Wind Net Margin/(Loss) | \$ (697,973) | | \$ (793,404) | | \$ (1,439,952) | |

| Wind Curtailment Expense | Month | Year To Date |
|---|--------------|---------------------|
| <i>(incl. in Purchased Electricity)</i> | \$ 146 | \$ 19,444 |

| | Actual |
|---------------------------|---------------|
| RECs at end of Prior Year | 3,442 |
| RECs Added This Year | 51,089 |
| RECs Sold This Year | 50,706 |
| Number of RECs on hand | 3,825 |
| Market Value per REC | \$ 2.79 |
| Value of RECs on Hand | \$ 10,672 |

Muscatine Power and Water

Water Utility

Financial Operating Statements & Balance Sheets

December 2025

**Muscatine Power and Water
Water Utility
Table of Contents**

| | Page |
|--|-------------|
| Classification of Water Distribution | 1 |
| Statements of Revenues, Expenses, and Changes in Net Position | 2-3 |
| Statements of Net Position | 4-5 |
| Statements of Cash Flows | 6 |
| Summary of Expenses | 7-10 |
| Statistical Data | 11 |

Muscatine Power and Water - Water Utility
Classification of Water Distribution
December 2025

Current Month

| Distribution | Results | | | Variance | | | | Average Use Per Customer | |
|---|----------------|----------------|----------------|------------------|---------------|-----------------|---------------|--------------------------|------------|
| | Actuals | Budget | Prior Year | Vs Budget | % | Vs Prior Year | % | Actual | Prior Year |
| Water Distribution - 1,000 Gallons | | | | | | | | | |
| Contract Customers | 621,786 | 696,230 | 688,617 | (74,444) | -10.7% | (66,831) | -9.7% | 310,893 | 344,309 |
| Power Plants | 19,810 | 25,383 | 21,562 | (5,573) | -22.0% | (1,752) | -8.1% | 9,905 | 10,781 |
| Residential ^{fn1} | 31,239 | 32,573 | 30,774 | (1,334) | -4.1% | 465 | 1.5% | 3.5 | 3.4 |
| Commercial ^{fn2} | 22,614 | 23,471 | 24,799 | (858) | -3.7% | (2,186) | -8.8% | 20 | 22 |
| Total Metered Customers | 695,449 | 777,657 | 765,752 | (82,209) | -10.6% | (70,304) | -9.2% | 69 | 77 |
| City Use | 461 | 103 | 136 | 358 | 347.6% | 325 | 239.0% | | |
| Losses, Flushing & Cycle Billing | 11,910 | 46,659 | 25,927 | (34,749) | -74.5% | (14,016) | -54.1% | | |
| TOTAL WATER PUMPED | 707,820 | 824,419 | 791,815 | (116,599) | -14.1% | (83,995) | -10.6% | | |

Year To Date

| Distribution | Results | | | Variance | | | | Average Use Per Customer | |
|---|------------------|-------------------|------------------|------------------|--------------|------------------|--------------|--------------------------|------------|
| | Actuals | Budget | Prior Year | Vs Budget | % | Vs Prior Year | % | Actual | Prior Year |
| Water Distribution - 1,000 Gallons | | | | | | | | | |
| Contract Customers | 8,071,173 | 8,648,204 | 8,542,098 | (577,031) | -6.7% | (470,925) | -5.5% | 4,035,586 | 4,276,821 |
| Power Plants | 354,902 | 343,500 | 293,376 | 11,402 | 3.3% | 61,526 | 21.0% | 177,451 | 145,894 |
| Residential ^{fn1} | 415,803 | 425,692 | 413,199 | (9,889) | -2.3% | 2,604 | 0.6% | 46.3 | 44.8 |
| Commercial ^{fn2} | 331,451 | 349,603 | 344,819 | (18,152) | -5.2% | (13,368) | -3.9% | 298 | 335 |
| Total Metered Customers | 9,173,328 | 9,766,998 | 9,593,492 | (593,670) | -6.1% | (420,163) | -4.4% | 909 | 968 |
| City Use | 24,369 | 26,753 | 21,268 | (2,384) | -8.9% | 3,101 | 14.6% | | |
| Losses, Flushing & Cycle Billing | 452,396 | 586,020 | 323,896 | (133,624) | -22.8% | 128,499 | 39.7% | | |
| TOTAL WATER PUMPED | 9,650,093 | 10,379,771 | 9,938,656 | (729,678) | -7.0% | (288,563) | -2.9% | | |

fn1 Includes an adjustment for unbilled gallons: 205K for 2025 and (392K) for 2024

fn2 Includes an adjustment for unbilled gallons: (95K) for 2025 and (86K) for 2024

Muscatine Power and Water - Water Utility
Statements of Revenues, Expenses, and Changes in Net Position
Current Month - December 2025

| Income Statement | Results | | | Variance | | | |
|---|----------------------|----------------------|----------------------|---------------------|---------------|---------------------|---------------|
| | Actual | Budget | Prior Year | Vs Budget \$ | % | Vs Prior Yr \$ | % |
| Revenue from Water Sales | | | | | | | |
| Contract Customers | \$ 387,976 | \$ 422,457 | \$ 412,491 | \$ (34,481) | -8.2% | \$ (24,515) | -5.9% |
| Power Plants | 29,216 | 31,016 | 27,890 | (1,801) | -5.8% | 1,326 | 4.8% |
| Residential ^{fn1} | 215,204 | 228,040 | 218,256 | (12,835) | -5.6% | (3,051) | -1.4% |
| Commercial ^{fn2} | 64,098 | 63,957 | 64,609 | 141 | 0.2% | (511) | -0.8% |
| Water Sales Revenue | 696,494 | 745,470 | 723,246 | (48,976) | -6.6% | (26,752) | -3.7% |
| Other Revenue | | | | | | | |
| Penalty Revenue | 1,235 | 1,212 | 1,215 | 23 | 1.9% | 20 | 1.6% |
| Merchandise & Job Sales-Net | 167 | 1,010 | 952 | (843) | -83.5% | (786) | -82.5% |
| Miscellaneous Revenue | 1,666 | 3,188 | 1,471 | (1,522) | -47.8% | 195 | 13.3% |
| Total Other Revenue | 3,067 | 5,410 | 3,638 | (2,343) | -43.3% | (571) | -15.7% |
| Operating Revenue | 699,561 | 750,880 | 726,883 | (51,319) | -6.8% | (27,323) | -3.8% |
| Operating Expense | | | | | | | |
| Purchased Electricity | 87,397 | 110,407 | 89,239 | 23,010 | 20.8% | 1,842 | 2.1% |
| Chemicals | 43,222 | 47,691 | 53,696 | 4,469 | 9.4% | 10,473 | 19.5% |
| Operations | 61,196 | 34,852 | 18,503 | (26,344) | -75.6% | (42,693) | -230.7% |
| Maintenance | 45,358 | 37,190 | 48,633 | (8,167) | -22.0% | 3,276 | 6.7% |
| Direct Labor | 136,297 | 104,404 | 114,330 | (31,893) | -30.5% | (21,967) | -19.2% |
| A&G Labor | 63,707 | 61,379 | 65,004 | (2,328) | -3.8% | 1,297 | 2.0% |
| A&G | 122,539 | 92,915 | 69,172 | (29,624) | -31.9% | (53,367) | -77.2% |
| Total Operating Expense | 559,716 | 488,838 | 458,576 | (70,878) | -14.5% | (101,140) | -22.1% |
| Operating Margin | 139,845 | 262,042 | 268,308 | (122,197) | -46.6% | (128,462) | -47.9% |
| Depreciation & Amortization | 100,652 | 97,870 | 96,411 | (2,782) | -2.8% | (4,241) | -4.4% |
| Operating Income | 39,194 | 164,172 | 171,897 | (124,978) | -76.1% | (132,703) | -77.2% |
| Nonoperating Income/(Expense) | | | | | | | |
| Interest Income | 28,074 | 15,150 | 20,736 | 12,923 | 85.3% | 7,338 | 35.4% |
| Interest Expense | (39,966) | (40,582) | (44,467) | 616 | 1.5% | 4,500 | 10.1% |
| Other Non-Operating Income | - | - | - | - | NM | - | NM |
| Gain/(Loss) on Disposal of Assets | 11,672 | - | - | 11,672 | NM | 11,672 | NM |
| Net Nonoperating Income/(Expense) | (221) | (25,432) | (23,731) | 25,211 | 99.1% | 23,510 | 99.1% |
| Net Income/(Loss) before Capital Contributions | 38,972 | 138,740 | 148,166 | (99,768) | -71.9% | (109,193) | -73.7% |
| Capital Contributions | - | - | - | - | NM | - | NM |
| Net Income/(Loss) | \$ 38,972 | \$ 138,740 | \$ 148,166 | \$ (99,768) | -71.9% | \$ (109,193) | -73.7% |
| Beginning Net Position | 31,683,255 | 24,130,315 | 22,834,832 | 7,552,940 | 31.3% | 8,848,423 | 38.7% |
| Change in Net Position | 38,972 | 138,740 | 148,166 | (99,768) | -71.9% | (109,193) | -73.7% |
| ENDING NET POSITION | \$ 31,722,227 | \$ 24,269,055 | \$ 22,982,998 | \$ 7,453,172 | 30.7% | \$ 8,739,229 | 38.0% |

fn1 Includes an adjustment to unbilled revenues of (\$1,335) for 2025 and \$1,469 for 2024

fn2 Includes an adjustment to unbilled revenues of \$352 for 2025 and \$286 for 2024

Muscatine Power and Water - Water Utility
Statements of Revenues, Expenses, and Changes in Net Position
Year To Date - December 2025

| Income Statement | Results | | | Variance | | | |
|---|----------------------|----------------------|----------------------|---------------------|---------------|---------------------|---------------|
| | Actual | Budget | Prior Year | Vs Budget \$ | % | Vs Prior Yr \$ | % |
| Revenue from Water Sales | | | | | | | |
| Contract Customers | \$ 4,814,550 | \$ 5,047,476 | \$ 4,924,226 | \$ (232,926) | -4.6% | \$ (109,675) | -2.2% |
| Power Plants | 377,187 | 371,865 | 338,365 | 5,321 | 1.4% | 38,822 | 11.5% |
| Residential ^{fn1} | 2,717,196 | 2,763,037 | 2,636,283 | (45,840) | -1.7% | 80,913 | 3.1% |
| Commercial ^{fn2} | 831,147 | 847,853 | 818,665 | (16,706) | -2.0% | 12,482 | 1.5% |
| Water Sales Revenue | 8,740,081 | 9,030,231 | 8,717,539 | (290,150) | -3.2% | 22,542 | 0.3% |
| Other Revenue | | | | | | | |
| Penalty Revenue | 12,552 | 13,130 | 10,980 | (578) | -4.4% | 1,572 | 14.3% |
| Merchandise & Job Sales-Net | 13,443 | 12,120 | 3,540 | 1,323 | 10.9% | 9,904 | 279.8% |
| Miscellaneous Revenue | 29,334 | 45,034 | 19,171 | (15,701) | -34.9% | 10,162 | 53.0% |
| Total Other Revenue | 55,329 | 70,284 | 33,691 | (14,955) | -21.3% | 21,638 | 64.2% |
| Operating Revenue | 8,795,410 | 9,100,515 | 8,751,230 | (305,106) | -3.4% | 44,180 | 0.5% |
| Operating Expense | | | | | | | |
| Purchased Electricity | 1,095,553 | 1,315,365 | 1,118,774 | 219,812 | 16.7% | 23,222 | 2.1% |
| Chemicals | 562,968 | 597,340 | 591,703 | 34,371 | 5.8% | 28,734 | 4.9% |
| Operations | 383,412 | 440,194 | 339,201 | 56,782 | 12.9% | (44,211) | -13.0% |
| Maintenance | 1,004,302 | 880,195 | 993,485 | (124,106) | -14.1% | (10,817) | -1.1% |
| Direct Labor | 1,409,622 | 1,242,904 | 1,286,515 | (166,718) | -13.4% | (123,107) | -9.6% |
| A&G Labor | 741,888 | 726,102 | 733,536 | (15,786) | -2.2% | (8,352) | -1.1% |
| A&G | 1,009,494 | 1,130,993 | 1,108,622 | 121,499 | 10.7% | 99,129 | 8.9% |
| Total Operating Expense | 6,207,238 | 6,333,093 | 6,171,837 | 125,854 | 2.0% | (35,402) | -0.6% |
| Operating Margin | 2,588,171 | 2,767,423 | 2,579,393 | (179,251) | -6.5% | 8,778 | 0.3% |
| Depreciation & Amortization | 1,189,123 | 1,176,183 | 1,140,835 | (12,940) | -1.1% | (48,289) | -4.2% |
| Operating Income | 1,399,048 | 1,591,239 | 1,438,559 | (192,191) | -12.1% | (39,511) | -2.7% |
| Nonoperating Income/(Expense) | | | | | | | |
| Interest Income | 243,103 | 181,804 | 255,265 | 61,299 | 33.7% | (12,163) | -4.8% |
| Interest Expense | (494,110) | (486,985) | (520,512) | (7,124) | -1.5% | 26,402 | 5.1% |
| Other Non-Operating Income | 7,576,302 | - | - | 7,576,302 | NM | 7,576,302 | NM |
| Gain/(Loss) on Disposal of Assets | 14,886 | - | 12,160 | 14,886 | NM | 2,726 | 22.4% |
| Net Nonoperating Income/(Expense) | 7,340,181 | (305,181) | (253,087) | 7,645,363 | NM | 7,593,268 | NM |
| Net Income/(Loss) before Capital Contributions | 8,739,229 | 1,286,058 | 1,185,472 | 7,453,172 | 579.5% | 7,553,757 | 637.2% |
| Capital Contributions | - | - | 3,500 | - | NM | (3,500) | NM |
| Net Income/(Loss) | \$ 8,739,229 | \$ 1,286,058 | \$ 1,188,972 | \$ 7,453,172 | 579.5% | \$ 7,550,257 | 635.0% |
| Beginning Net Position | 22,982,998 | 22,982,998 | 21,794,026 | - | 0.0% | 1,188,972 | 5.5% |
| Change in Net Position | 8,739,229 | 1,286,058 | 1,188,972 | 7,453,172 | 579.5% | 7,550,257 | 635.0% |
| ENDING NET POSITION | \$ 31,722,227 | \$ 24,269,055 | \$ 22,982,998 | \$ 7,453,172 | 30.7% | \$ 8,739,229 | 38.0% |

fn1 Includes an adjustment to unbilled revenues of (\$1,335) for 2025 and \$1,469 for 2024

fn2 Includes an adjustment to unbilled revenues of \$352 for 2025 and \$286 for 2024

Muscatine Power and Water - Water Utility
Statements of Net Position
December 2025

| ASSETS | | | |
|---|----------------------|----------------------|----------------------|
| | 2025 | Prior Month | Prior Year |
| Current Assets: | | | |
| Unrestricted Assets | | | |
| Cash - interest bearing | \$ 644,057 | \$ 1,581,403 | \$ 3,073,102 |
| Investments - Securities | 1,750,000 | 1,750,000 | 1,550,000 |
| PFAS - Cash & Investments | 4,363,923 | 4,363,923 | - |
| Receivables: | | | |
| Consumer Accounts | 888,440 | 1,287,507 | 1,154,851 |
| Interest | 63,904 | 46,270 | 34,759 |
| Settlement | 597,652 | 597,652 | - |
| Inventories | 655,354 | 557,863 | 580,090 |
| Prepaid Expenses | 61,356 | 78,231 | 53,552 |
| Total Unrestricted Current Assets | 9,024,685 | 10,262,849 | 6,446,355 |
| Restricted Assets | | | |
| Cash - interest bearing | 153,409 | 781,967 | 136,732 |
| Total Restricted Current Assets | 153,409 | 781,967 | 136,732 |
| Total Current Assets | 9,178,094 | 11,044,815 | 6,583,087 |
| Non-Current Assets: | | | |
| Capital Assets: | | | |
| Property, Plant & Equipment | 48,379,471 | 46,358,931 | 45,997,433 |
| Subscription-Based IT Assets | 313,000 | 313,000 | 264,817 |
| Construction Work in Progress | 411,332 | 2,497,667 | 358,107 |
| Less: Accumulated Depreciation & Amortization | (16,180,624) | (16,222,152) | (15,133,680) |
| Total Capital Assets | 32,923,180 | 32,947,446 | 31,486,677 |
| Other Assets: | | | |
| Unamortized debt insurance costs | 28,856 | 29,101 | 31,903 |
| Settlement Receivable | 2,614,727 | 2,614,727 | - |
| Net pension asset | - | - | - |
| Total Other Assets | 2,643,583 | 2,643,828 | 31,903 |
| Total Non-Current Assets | 35,566,763 | 35,591,274 | 31,518,580 |
| Deferred Outflows of Resources | | | |
| Pension | 312,293 | 793,125 | 591,165 |
| OPEB | 59,466 | 19,650 | 23,427 |
| IPERS | 120,938 | 120,938 | 120,938 |
| Total Deferred Outflows of Resources | 492,697 | 933,713 | 735,530 |
| TOTAL ASSETS | \$ 45,237,554 | \$ 47,569,802 | \$ 38,837,197 |

Muscatine Power and Water - Water Utility
Statements of Net Position
December 2025

| LIABILITIES AND NET POSITION | | | |
|---|----------------------|----------------------|----------------------|
| | 2025 | Prior Month | Prior Year |
| Current Liabilities: | | | |
| Payable from Unrestricted Assets: | | | |
| Accounts Payable | \$ 100,975 | \$ (25,433) | \$ 75,138 |
| Health & Dental Insurance Provision | 21,815 | 29,782 | 29,782 |
| Accrued Payroll | 67,724 | 42,530 | 44,597 |
| Accrued Compensated Absences | 218,601 | 222,022 | 213,039 |
| Accrued Property Taxes | 3,952 | 3,623 | 3,868 |
| Miscellaneous Accrued Expenses | 71,677 | 73,672 | 62,223 |
| Unearned Revenue | 1,200 | 1,200 | 1,200 |
| Total Payable from Unrestricted Assets | 485,944 | 347,395 | 429,847 |
| Payable from Restricted Assets | | | |
| Electric Utility Loan - Current Portion | - | 278,324 | 272,199 |
| Water Revenue Bonds | 490,000 | 470,000 | 470,000 |
| Accrued Interest | 37,996 | 265,151 | 39,954 |
| Total Payable from Restricted Assets | 527,996 | 1,013,474 | 782,153 |
| Total Current Liabilities | 1,013,940 | 1,360,870 | 1,212,000 |
| Non-Current Liabilities: | | | |
| Water Revenue Bond Series 2017 | 11,340,824 | 11,834,711 | 11,888,428 |
| Electric Utility Loan | - | 1,077,720 | 1,218,430 |
| Health & Dental Insurance Provision | 1,939 | 5,685 | 5,023 |
| Post-Employment Health Benefit Provision | 167,280 | 125,564 | 123,194 |
| Subscription Based IT Arrangements | 142,245 | 146,422 | 164,457 |
| Net Pension Liability | 536,167 | 1,014,096 | 918,436 |
| Total Non-Current Liabilities | 12,188,456 | 14,204,197 | 14,317,967 |
| Deferred Inflows of Resources | | | |
| Pension | 245,019 | 258,793 | 258,793 |
| OPEB | 11,527 | 6,302 | 9,053 |
| IPERS | 56,385 | 56,385 | 56,385 |
| Total Deferred Inflows of Resources | 312,932 | 321,481 | 324,232 |
| Net Position: | | | |
| Net Investment in Capital Assets | 21,092,355 | 19,286,691 | 17,637,620 |
| Restricted | 115,413 | 516,816 | 96,778 |
| Unrestricted | 10,514,459 | 11,879,748 | 5,248,600 |
| Total Net Position | 31,722,227 | 31,683,255 | 22,982,998 |
| TOTAL LIABILITIES AND NET POSITION | \$ 45,237,554 | \$ 47,569,802 | \$ 38,837,197 |

Muscatine Power and Water - Water Utility
Statements of Cash Flows
December 2025

| | <u>Month</u> | <u>Year To Date</u> |
|---|---------------------|---------------------|
| Cash Flows from Operating Activities | | |
| Operating Margin | \$ 139,845 | \$ 2,588,171 |
| Change in Deferred Outflows of Resources | 441,016 | 242,833 |
| Change in Deferred Inflows of Resources | (8,549) | (11,300) |
| Changes in Assets and Liabilities: | | |
| Consumer Accounts Receivable | 399,067 | 266,411 |
| Inventories | (97,490) | (75,264) |
| Prepaid and Deferred Expenses | 16,875 | (7,803) |
| Accounts Payable | 126,408 | 25,837 |
| Net Pension Liability | (477,929) | (382,269) |
| Health & Dental Insurance Provision | (11,714) | (11,051) |
| Other Post-Employment Benefit Provision | 41,716 | 44,086 |
| Accrued Payroll | 25,194 | 23,127 |
| Accrued Compensated Absences | (3,421) | 5,562 |
| Accrued Property Taxes | 329 | 84 |
| Unearned Revenue | - | - |
| Miscellaneous Accrued Expenses | (1,995) | 9,453 |
| Net Cash Flows from Operating Activities | 589,354 | 2,717,878 |
| Cash Flows from Capital and Financing Activities: | | |
| Capital Expenditures | (81,089) | (2,654,962) |
| Gain/(Loss) on Disposal of Assets | 11,672 | 14,886 |
| Settlements Received | - | 4,363,923 |
| Electric Utility Loan Interest & Principal Payments | (1,386,555) | (1,554,679) |
| Water Revenue Bond Interest & Principal Payments | (709,725) | (949,450) |
| Net Cash Flows from Capital & Financing Activities | (2,165,697) | (780,282) |
| Cash Flows from Investing Activities: | | |
| Interest Received on Investments | 10,439 | 213,958 |
| Net Cash Flows from Investing Activities | 10,439 | 213,958 |
| Net Increase/(Decrease) in Cash and Investments | (1,565,904) | 2,151,555 |
| Cash and Investments at Beginning of Period | \$ 8,477,293 | 4,759,834 |
| Cash and Investments at End of Period | \$ 6,911,389 | \$ 6,911,389 |

Muscatine Power and Water - Water Utility
Summary of Expenses
Current Month - December 2025

| Summary of Expenses | Results | | | Variance | | | |
|--|----------------|----------------|----------------|-----------------|---------------|-----------------|---------------|
| | Actual | Budget | Prior Year | Vs Budget \$ | % | Vs Prior Yr \$ | % |
| Source of Supply | | | | | | | |
| Operation Expenses (601) | \$ - | \$ 43 | \$ 9 | \$ 43 | NM | \$ 9 | NM |
| Miscellaneous Expense (603) | - | 411 | - | 411 | NM | - | NM |
| Maintenance of Wells (614) | - | - | 370 | - | NM | 370 | NM |
| Maintenance of Supply Mains (616) | - | - | - | - | NM | - | NM |
| Source of Supply Labor | 5,030 | 5,982 | 4,101 | 952 | 15.9% | (929) | -22.7% |
| Total Source of Supply Expense | 5,030 | 6,435 | 4,479 | 1,406 | 21.8% | (550) | -12.3% |
| <i>% of Operating Revenue</i> | <i>0.7%</i> | <i>0.9%</i> | <i>0.6%</i> | | | | |
| Pumping | | | | | | | |
| Purchased Electricity (623) | 87,397 | 110,407 | 89,239 | 23,010 | 20.8% | 1,842 | 2.1% |
| Pumping Expenses (624) | 58 | 242 | - | 184 | 76.0% | (58) | NM |
| Miscellaneous Expense (626) | 315 | 292 | 234 | (23) | -8.0% | (81) | -34.6% |
| Maintenance of Structures (631) | - | - | - | - | NM | - | NM |
| Maintenance of Pumping Equipment (632/633) | 6,571 | 3,583 | 2,647 | (2,987) | -83.4% | (3,924) | -148.2% |
| Pumping Labor | 6,183 | 9,677 | 5,449 | 3,494 | 36.1% | (733) | -13.5% |
| Total Pumping Expense | 100,523 | 124,200 | 97,569 | 23,677 | 19.1% | (2,954) | -3.0% |
| <i>% of Operating Revenue</i> | <i>14.4%</i> | <i>16.5%</i> | <i>13.4%</i> | | | | |
| Water Treatment | | | | | | | |
| Chemicals (641) | 43,222 | 47,691 | 53,696 | 4,469 | 9.4% | 10,473 | 19.5% |
| Operation Expenses (642) | 24,124 | 16,338 | 8,371 | (7,786) | -47.7% | (15,753) | -188.2% |
| Miscellaneous Expense (643) | 58 | 750 | 492 | 692 | 92.3% | 434 | 88.2% |
| Maintenance of Structures (651) | 523 | 400 | 2,038 | (123) | -30.9% | 1,514 | 74.3% |
| Maintenance of Purification Equip. (652) | 198 | 1,000 | 4,596 | 802 | 80.2% | 4,397 | 95.7% |
| Water Treatment Labor | 18,478 | 23,359 | 27,375 | 4,881 | 20.9% | 8,897 | 32.5% |
| Total Water Treatment Expense | 86,604 | 89,538 | 96,567 | 2,934 | 3.3% | 9,963 | 10.3% |
| <i>% of Operating Revenue</i> | <i>12.4%</i> | <i>11.9%</i> | <i>13.3%</i> | | | | |
| Distribution | | | | | | | |
| Storage Facilities Expense (661) | 28,637 | 6,465 | 5,347 | (22,172) | -343.0% | (23,290) | -435.6% |
| Trans. & Distr. Lines Expense (662) | 1,381 | 1,017 | 115 | (363) | -35.7% | (1,265) | NM |
| Meter Expense (663) | 4,313 | 566 | 56 | (3,747) | -662.0% | (4,257) | NM |
| Customer Installation Expense (664) | 75 | 1,250 | 86 | 1,175 | 94.0% | 11 | 13.1% |
| Miscellaneous Expense (665) | 216 | 536 | 297 | 319 | 59.6% | 81 | 27.3% |
| Vehicle Expense (667) | 2,020 | 6,944 | 3,495 | 4,924 | 70.9% | 1,475 | 42.2% |
| Maintenance: | | | | | | | |
| Structures (671) | 332 | 283 | 127 | (49) | -17.3% | (206) | -162.4% |
| Reservoirs and Standpipes (672) | - | 10,208 | 43 | 10,208 | NM | 43 | NM |
| Mains (673) | 30,037 | 14,167 | 32,347 | (15,871) | -112.0% | 2,310 | 7.1% |
| Valves (674) | 1,272 | 5,000 | 5,358 | 3,728 | 74.6% | 4,086 | 76.3% |
| Meters (676) | 21 | 1,050 | - | 1,029 | 98.0% | (21) | NM |
| Hydrants (677) | 5,184 | 1,000 | 45 | (4,184) | -418.4% | (5,139) | NM |
| Miscellaneous Plant (678) | 1,219 | 499 | 1,063 | (720) | -144.3% | (156) | -14.6% |
| Distribution Labor | 106,607 | 65,386 | 77,406 | (41,220) | -63.0% | (29,201) | -37.7% |
| Total Distribution Expense | 181,313 | 114,371 | 125,785 | (66,942) | -58.5% | (55,528) | -44.1% |
| <i>% of Operating Revenue</i> | <i>25.9%</i> | <i>15.2%</i> | <i>17.3%</i> | | | | |

Muscatine Power and Water - Water Utility
Summary of Expenses
Current Month - December 2025

| Summary of Expenses | Results | | | Variance | | | |
|---|-------------------|-------------------|-------------------|--------------------|---------------|---------------------|---------------|
| | Actual | Budget | Prior Year | Vs Budget \$ | % | Vs Prior Yr \$ | % |
| Customer Information Expense (909) | 1,445 | 1,573 | 3,478 | 127 | 8.1% | 2,033 | 58.4% |
| <i>% of Operating Revenue</i> | 0.2% | 0.2% | 0.5% | | | | |
| Consumer Accounts | | | | | | | |
| Meter Reading Expense (902) | 191 | 278 | 214 | 88 | 31.6% | 23 | 10.9% |
| Consumer Records and Collection (901/903) | 8,803 | 5,955 | 4,709 | (2,848) | -47.8% | (4,094) | -86.9% |
| Uncollectible Accounts Expense (904) | (1,894) | 1,400 | 5,307 | 3,295 | NM | 7,202 | NM |
| Total Consumer Accounts Expense | 7,099 | 7,633 | 10,230 | 534 | 7.0% | 3,131 | 30.6% |
| <i>% of Operating Revenue</i> | 1.0% | 1.0% | 1.4% | | | | |
| Administrative and General | | | | | | | |
| Office Supplies and Expenses (921) | 5,498 | 2,470 | (10) | (3,028) | -122.6% | (5,508) | NM |
| Outside Services Employed (923) | 2,405 | 24,192 | 5,555 | 21,787 | 90.1% | 3,150 | 56.7% |
| Property Insurance (924) | 6,631 | 8,162 | 5,495 | 1,531 | 18.8% | (1,136) | -20.7% |
| Casualty Ins, Injuries & Damages (925) | 3,616 | 6,837 | 8,159 | 3,221 | 47.1% | 4,543 | 55.7% |
| Employee Benefits (926) | 63,608 | 46,376 | 7,726 | (17,232) | -37.2% | (55,882) | -723.3% |
| Employee Pensions (926-PEN) | 7,489 | 14,129 | 9,406 | 6,640 | 47.0% | 1,916 | 20.4% |
| Fringe Benefits Charged to Constr. (927) | (1,616) | (5,833) | - | (4,218) | -72.3% | 1,616 | NM |
| Miscellaneous General Expense (930) | 9,477 | 9,632 | 5,769 | 155 | 1.6% | (3,708) | -64.3% |
| A&G Adder (930-AGA) | 2,010 | (37,520) | - | (39,530) | NM | (2,010) | NM |
| Rents (931) | 7,487 | 7,487 | 7,269 | 0 | 0.0% | (218) | -3.0% |
| Maintenance of General Plant (932) | 7,390 | 7,778 | 6,095 | 388 | 5.0% | (1,295) | -21.2% |
| A&G Labor | 63,707 | 61,379 | 65,004 | (2,328) | -3.8% | 1,297 | 2.0% |
| Total Administrative and General | 177,702 | 145,088 | 120,467 | (32,614) | -22.5% | (57,234) | -47.5% |
| <i>% of Operating Revenue</i> | 25.4% | 19.3% | 16.6% | | | | |
| TOTAL OPERATING EXPENSES | \$ 559,716 | \$ 488,838 | \$ 458,576 | \$ (70,878) | -14.5% | \$ (101,140) | -22.1% |
| <i>% of Operating Revenue</i> | 80.0% | 65.1% | 63.1% | | | | |

| Depreciation & Amortization | | | | | | | |
|--|-------------------|------------------|------------------|-------------------|--------------|-------------------|--------------|
| Source of Supply Depreciation (618) | \$ 8,866 | \$ 8,776 | \$ 8,866 | \$ (90) | -1.0% | \$ 0 | 0.0% |
| Pumping Depreciation (634) | 8,317 | 10,711 | 8,222 | 2,394 | 22.3% | (95) | -1.2% |
| Water Treatment Depreciation (654) | 4,800 | 4,732 | 4,722 | (68) | -1.4% | (78) | -1.7% |
| Distribution Depreciation (680) | 60,346 | 58,242 | 57,621 | (2,103) | -3.6% | (2,724) | -4.7% |
| A&G Depreciation (933) | 12,643 | 11,349 | 12,210 | (1,294) | -11.4% | (434) | -3.6% |
| Subscription-Based IT Arrangements (428) | 5,679 | 4,059 | 4,770 | (1,620) | -39.9% | (909) | -19.1% |
| Total Depreciation & Amortization | \$ 100,652 | \$ 97,870 | \$ 96,411 | \$ (2,782) | -2.8% | \$ (4,241) | -4.4% |
| <i>% of Operating Revenue</i> | 14.4% | 13.0% | 13.3% | | | | |

Muscatine Power and Water - Water Utility
Summary of Expenses
Year To Date - December 2025

| Summary of Expenses | Results | | | Variance | | | |
|--|------------------|------------------|------------------|------------------|---------------|------------------|---------------|
| | Actual | Budget | Prior Year | Vs Budget \$ | % | Vs Prior Yr \$ | % |
| Source of Supply | | | | | | | |
| Operation Expenses (601) | \$ 159 | \$ 514 | \$ 1,348 | \$ 355 | 69.0% | \$ 1,189 | 88.2% |
| Miscellaneous Expense (603) | 14,880 | 20,199 | 19,035 | 5,319 | 26.3% | 4,155 | 21.8% |
| Maintenance of Wells (614) | 344,382 | 326,000 | 321,716 | (18,382) | -5.6% | (22,666) | -7.0% |
| Maintenance of Supply Mains (616) | - | 3,000 | - | 3,000 | NM | - | NM |
| Source of Supply Labor | 68,380 | 71,014 | 62,427 | 2,634 | 3.7% | (5,954) | -9.5% |
| Total Source of Supply Expense | 427,801 | 420,727 | 404,526 | (7,074) | -1.7% | (23,275) | -5.8% |
| % of Operating Revenue | 4.9% | 4.6% | 55.7% | | | | |
| Pumping | | | | | | | |
| Purchased Electricity (623) | 1,095,553 | 1,315,365 | 1,118,774 | 219,812 | 16.7% | 23,222 | 2.1% |
| Pumping Expenses (624) | 5,315 | 3,000 | 1,396 | (2,315) | -77.2% | (3,920) | -280.8% |
| Miscellaneous Expense (626) | 3,676 | 3,502 | 3,989 | (174) | -5.0% | 313 | 7.8% |
| Maintenance of Structures (631) | - | - | - | - | NM | - | NM |
| Maintenance of Pumping Equipment (632/633) | 225,532 | 214,500 | 313,616 | (11,032) | -5.1% | 88,084 | 28.1% |
| Pumping Labor | 97,901 | 115,393 | 94,719 | 17,492 | 15.2% | (3,182) | -3.4% |
| Total Pumping Expense | 1,427,977 | 1,651,760 | 1,532,494 | 223,784 | 13.5% | 104,518 | 6.8% |
| % of Operating Revenue | 16.2% | 18.2% | 210.8% | | | | |
| Water Treatment | | | | | | | |
| Chemicals (641) | 562,968 | 597,340 | 591,703 | 34,371 | 5.8% | 28,734 | 4.9% |
| Operation Expenses (642) | 162,726 | 195,694 | 119,158 | 32,968 | 16.8% | (43,567) | -36.6% |
| Miscellaneous Expense (643) | 3,308 | 9,270 | 5,931 | 5,962 | 64.3% | 2,623 | 44.2% |
| Maintenance of Structures (651) | 12,604 | 7,660 | 35,309 | (4,944) | -64.5% | 22,705 | 64.3% |
| Maintenance of Purification Equip. (652) | 19,405 | 12,000 | 19,417 | (7,405) | -61.7% | 12 | 0.1% |
| Water Treatment Labor | 256,718 | 279,208 | 257,522 | 22,490 | 8.1% | 804 | 0.3% |
| Total Water Treatment Expense | 1,017,729 | 1,101,171 | 1,029,040 | 83,442 | 7.6% | 11,311 | 1.1% |
| % of Operating Revenue | 11.6% | 12.1% | 141.6% | | | | |
| Distribution | | | | | | | |
| Storage Facilities Expense (661) | 101,623 | 83,921 | 72,573 | (17,702) | -21.1% | (29,051) | -40.0% |
| Trans. & Distr. Lines Expense (662) | 18,177 | 12,206 | 23,165 | (5,971) | -48.9% | 4,988 | 21.5% |
| Meter Expense (663) | 23,198 | 10,986 | 21,936 | (12,212) | -111.2% | (1,262) | -5.8% |
| Customer Installation Expense (664) | 12,701 | 15,000 | 12,419 | 2,299 | 15.3% | (282) | -2.3% |
| Miscellaneous Expense (665) | 361 | 5,727 | 3,752 | 5,366 | 93.7% | 3,391 | 90.4% |
| Vehicle Expense (667) | 37,288 | 80,175 | 54,499 | 42,887 | 53.5% | 17,211 | 31.6% |
| Maintenance: | | | | | | | |
| Structures (671) | 2,014 | 22,000 | 2,060 | 19,986 | 90.8% | 46 | 2.2% |
| Reservoirs and Standpipes (672) | 2,564 | 36,000 | 18,113 | 33,436 | 92.9% | 15,549 | 85.8% |
| Mains (673) | 260,463 | 170,000 | 166,831 | (90,463) | -53.2% | (93,632) | -56.1% |
| Valves (674) | 34,081 | 60,000 | 34,430 | 25,919 | 43.2% | 350 | 1.0% |
| Meters (676) | 47,557 | 12,600 | 6,584 | (34,957) | -277.4% | (40,973) | -622.3% |
| Hydrants (677) | 26,778 | 12,000 | 41,768 | (14,778) | -123.1% | 14,990 | 35.9% |
| Miscellaneous Plant (678) | 28,922 | 4,435 | 33,640 | (24,487) | -552.1% | 4,718 | 14.0% |
| Distribution Labor | 986,623 | 777,289 | 871,848 | (209,334) | -26.9% | (114,776) | -13.2% |
| Total Distribution Expense | 1,582,350 | 1,302,339 | 1,363,618 | (280,011) | -21.5% | (218,732) | -16.0% |
| % of Operating Revenue | 18.0% | 14.3% | 187.6% | | | | |

Muscatine Power and Water - Water Utility
Summary of Expenses
Year To Date - December 2025

| Summary of Expenses | Results | | | Variance | | | |
|---|---------------------|---------------------|---------------------|-------------------|--------------|--------------------|---------------|
| | Actual | Budget | Prior Year | Vs Budget \$ | % | Vs Prior Yr \$ | % |
| Customer Information Expense (909) | 17,486 | 20,974 | 13,245 | 3,488 | 16.6% | (4,241) | -32.0% |
| <i>% of Operating Revenue</i> | 0.2% | 0.2% | 1.8% | | | | |
| Consumer Accounts | | | | | | | |
| Meter Reading Expense (902) | 2,445 | 3,341 | 2,861 | 896 | 26.8% | 416 | 14.5% |
| Consumer Records and Collection (901/903) | 60,420 | 70,971 | 67,811 | 10,551 | 14.9% | 7,391 | 10.9% |
| Uncollectible Accounts Expense (904) | 25,905 | 16,803 | 22,320 | (9,102) | -54.2% | (3,585) | -16.1% |
| Total Consumer Accounts Expense | 88,770 | 91,114 | 92,991 | 2,344 | 2.6% | 4,221 | 4.5% |
| <i>% of Operating Revenue</i> | 1.0% | 1.0% | 12.8% | | | | |
| Administrative and General | | | | | | | |
| Office Supplies and Expenses (921) | 26,151 | 23,581 | 18,241 | (2,569) | -10.9% | (7,909) | -43.4% |
| Outside Services Employed (923) | 74,864 | 114,570 | 27,934 | 39,706 | 34.7% | (46,930) | -168.0% |
| Property Insurance (924) | 56,863 | 72,889 | 52,547 | 16,026 | 22.0% | (4,316) | -8.2% |
| Casualty Ins, Injuries & Damages (925) | 63,521 | 79,780 | 81,518 | 16,259 | 20.4% | 17,997 | 22.1% |
| Employee Benefits (926) | 694,557 | 557,853 | 580,113 | (136,704) | -24.5% | (114,443) | -19.7% |
| Employee Pensions (926-PEN) | 103,149 | 169,546 | 139,298 | 66,397 | 39.2% | 36,149 | 26.0% |
| Fringe Benefits Charged to Constr. (927) | (79,924) | (70,000) | (61,476) | 9,924 | 14.2% | 18,448 | 30.0% |
| Miscellaneous General Expense (930) | 67,289 | 102,291 | 63,234 | 35,003 | 34.2% | (4,055) | -6.4% |
| A&G Adder (930-AGA) | (280,015) | (225,121) | (59,984) | 54,894 | 24.4% | 220,031 | 366.8% |
| Rents (931) | 89,840 | 89,841 | 87,224 | 0 | 0.0% | (2,616) | -3.0% |
| Maintenance of General Plant (932) | 86,944 | 103,675 | 73,738 | 16,731 | 16.1% | (13,206) | -17.9% |
| A&G Labor | 741,888 | 726,102 | 733,536 | (15,786) | -2.2% | (8,352) | -1.1% |
| Total Administrative and General | 1,645,126 | 1,745,007 | 1,735,922 | 99,881 | 5.7% | 90,796 | 5.2% |
| <i>% of Operating Revenue</i> | 18.7% | 19.2% | 238.8% | | | | |
| TOTAL OPERATING EXPENSES | \$ 6,207,238 | \$ 6,333,093 | \$ 6,171,837 | \$ 125,854 | 2.0% | \$ (35,402) | -0.6% |
| <i>% of Operating Revenue</i> | 70.6% | 69.6% | 849.1% | | | | |

| Depreciation & Amortization | | | | | | | |
|--|---------------------|---------------------|---------------------|--------------------|--------------|--------------------|--------------|
| Source of Supply Depreciation (618) | \$ 106,387 | \$ 105,312 | \$ 105,491 | \$ (1,075) | -1.0% | \$ (896) | -0.8% |
| Pumping Depreciation (634) | 97,258 | 128,536 | 98,665 | 31,278 | 24.3% | 1,407 | 1.4% |
| Water Treatment Depreciation (654) | 57,610 | 56,788 | 56,788 | (822) | -1.4% | (822) | -1.4% |
| Distribution Depreciation (680) | 716,179 | 698,907 | 688,799 | (17,273) | -2.5% | (27,380) | -4.0% |
| A&G Depreciation (933) | 147,698 | 136,194 | 135,817 | (11,504) | -8.4% | (11,881) | -8.7% |
| Subscription-Based IT Arrangements (428) | 63,991 | 50,447 | 55,273 | (13,544) | -26.8% | (8,718) | -15.8% |
| Total Depreciation & Amortization | \$ 1,189,123 | \$ 1,176,183 | \$ 1,140,835 | \$ (12,940) | -1.1% | \$ (48,289) | -4.2% |
| <i>% of Operating Revenue</i> | 13.5% | 13.4% | 156.9% | | | | |

**Muscatine Power and Water - Water Utility
Statistical Data
December 2025**

Current Month

| Margin | 2025 | | Prior Year | |
|-----------------------------------|------------------|------------------|------------------|------------------|
| Margin per 1,000 Gallons | Pumped | Sold | Pumped | Sold |
| Average Revenue Per 1,000 Gallons | \$ 0.9840 | \$ 1.0015 | \$ 0.9134 | \$ 0.9445 |
| Cost Per 1,000 Gallons | 0.7908 | 0.8048 | 0.5791 | 0.5989 |
| Margin | \$ 0.1932 | \$ 0.1967 | \$ 0.3343 | \$ 0.3456 |

| Average Price per 1,000 Gallons | Results | | | Variance | | | |
|---------------------------------|------------------|------------------|------------------|------------------|-------------|------------------|-------------|
| Sales of Water | Actual | Budget | Prior Year | Vs Budget | % | Vs Prior Year | % |
| Contract Customers | \$ 0.6240 | \$ 0.6068 | \$ 0.5990 | \$ 0.0172 | 2.8% | \$ 0.0250 | 4.2% |
| Power Plants | 1.4748 | 1.2219 | 1.2935 | 0.2529 | 20.7% | 0.1813 | 14.0% |
| Residential | 6.8890 | 7.0009 | 7.0922 | (0.1119) | -1.6% | (0.2032) | -2.9% |
| Commercial | 2.8345 | 2.7249 | 2.6053 | 0.1096 | 4.0% | 0.2292 | 8.8% |
| Water Sales | \$ 1.0015 | \$ 0.9586 | \$ 0.9445 | \$ 0.0429 | 4.5% | \$ 0.0570 | 6.0% |

Year To Date

| Margin | 2025 | | Prior Year | |
|-----------------------------------|------------------|------------------|------------------|------------------|
| Margin per 1,000 Gallons | Pumped | Sold | Pumped | Sold |
| Average Revenue Per 1,000 Gallons | \$ 0.9057 | \$ 0.9528 | \$ 0.8771 | \$ 0.9087 |
| Cost Per 1,000 Gallons | 0.6432 | 0.6767 | 0.6210 | 0.6433 |
| Margin | \$ 0.2625 | \$ 0.2761 | \$ 0.2561 | \$ 0.2654 |

| Average Price per 1,000 Gallons | Results | | | Variance | | | |
|---------------------------------|------------------|------------------|------------------|------------------|-------------|------------------|-------------|
| Sales of Water | Actual | Budget | Prior Year | Vs Budget | % | Vs Prior Year | % |
| Contract Customers | \$ 0.5965 | \$ 0.5836 | \$ 0.5765 | \$ 0.0129 | 2.2% | \$ 0.0200 | 3.5% |
| Power Plants | 1.0628 | 1.0826 | 1.1533 | (0.0198) | -1.8% | (0.0906) | -7.9% |
| Residential | 6.5348 | 6.4907 | 6.3802 | 0.0441 | 0.7% | 0.1546 | 2.4% |
| Commercial | 2.5076 | 2.4252 | 2.3742 | 0.0824 | 3.4% | 0.1334 | 5.6% |
| Water Sales | \$ 0.9528 | \$ 0.9246 | \$ 0.9087 | \$ 0.0282 | 3.1% | \$ 0.0441 | 4.9% |

| Maximum Daily Water Pumped (1,000 gallons) | 2025 | Prior Year |
|--|-----------|------------|
| Maximum Daily Water Pumped - Month | 24,665 | 27,282 |
| Date of Maximum | 12/6/2025 | 12/8/2024 |
| Maximum Daily Water Pumped - Year | 34,692 | 31,319 |
| Date of Maximum | 7/23/2025 | 5/23/2024 |
| All-time Peak - August 2003 | 38,500 | |

| Services | 2025 | Prior Year | Vs. Prior Year % |
|--------------------|---------------|---------------|------------------|
| Contract Customers | 2 | 2 | 0.0% |
| Power Plants | 2 | 2 | 0.0% |
| Residential | 8,973 | 8,983 | -0.1% |
| Commercial | 1,111 | 1,104 | 0.6% |
| Total | 10,088 | 10,091 | 0.0% |

Muscatine Power and Water

Communications Utility

Financial Operating Statements & Balance Sheets

December 2025

**Muscatine Power and Water
Communications Utility
Table of Contents**

| | |
|--|------------|
| Statements of Revenues, Expenses, and Changes in Net Position | 1-2 |
| Statements of Net Position | 3-4 |
| Statements of Cash Flows | 5 |
| Summary of Expenses | 6-9 |
| Statistical Data | 10 |

Muscatine Power and Water - Communications Utility
Statements of Revenues, Expenses, and Changes in Net Position
Current Month - December 2025

| Income Statement | Results | | | Variance | | | |
|---|----------------------|----------------------|----------------------|-------------------|---------------|---------------------|---------------|
| | Actual | Budget | Prior Year | Vs Budget \$ | % | Vs Prior Yr \$ | % |
| Operating Revenue | | | | | | | |
| Video ^{fn1} | \$ 451,010 | \$ 457,182 | \$ 501,908 | \$ (6,172) | -1.4% | \$ (50,898) | -10.1% |
| Data/Internet ^{fn2} | 665,421 | 669,516 | 719,254 | (4,095) | -0.6% | (53,834) | -7.5% |
| Enterprise | 91,929 | 64,500 | 77,803 | 27,429 | 42.5% | 14,126 | 18.2% |
| Phone ^{fn3} | 30,191 | 33,708 | 34,189 | (3,517) | -10.4% | (3,998) | -11.7% |
| Miscellaneous | 7,826 | 5,846 | 7,501 | 1,980 | 33.9% | 325 | 4.3% |
| Inter-Utility Revenue | 17,410 | 12,500 | 12,031 | 4,910 | 39.3% | 5,379 | 44.7% |
| Total Operating Revenue | 1,263,786 | 1,243,251 | 1,352,686 | 20,535 | 1.7% | (88,900) | -6.6% |
| Operating Expense | | | | | | | |
| Programming | 322,605 | 334,692 | 335,722 | 12,088 | 3.6% | 13,118 | 3.9% |
| Video Margin \$ | 128,405 | 122,490 | 166,186 | 5,915 | 4.8% | (37,781) | -22.7% |
| Video Margin % | 28.5% | 26.8% | 33.1% | | | | |
| Data Access Fees | 18,183 | 19,214 | 12,518 | 1,031 | 5.4% | (5,664) | -45.2% |
| Operations | 156,054 | 111,729 | 76,621 | (44,325) | -39.7% | (79,434) | -103.7% |
| Maintenance | 41,310 | 56,575 | 50,879 | 15,265 | 27.0% | 9,569 | 18.8% |
| Direct Labor | 169,775 | 152,138 | 153,436 | (17,637) | -11.6% | (16,339) | -10.6% |
| A&G Labor | 137,792 | 121,982 | 128,626 | (15,809) | -13.0% | (9,166) | -7.1% |
| A&G | 241,112 | 201,070 | 164,079 | (40,042) | -19.9% | (77,033) | -46.9% |
| Total Operating Expense | 1,086,829 | 997,401 | 921,881 | (89,429) | -9.0% | (164,948) | -17.9% |
| Operating Margin | 176,957 | 245,851 | 430,805 | (68,894) | -28.0% | (253,848) | -58.9% |
| Depreciation & Amortization | 183,923 | 132,649 | 239,453 | (51,274) | -38.7% | 55,530 | 23.2% |
| Operating Income | (6,966) | 113,202 | 191,352 | (120,168) | NM | (198,318) | NM |
| Interest Income | 27,369 | 25,975 | 35,386 | 1,395 | 5.4% | (8,017) | -22.7% |
| Interest Expense | (9,187) | (9,452) | (18,565) | 265 | 2.8% | 9,379 | 50.5% |
| Gain/(Loss) on Disposal of Assets | - | - | - | - | NM | - | NM |
| Net Nonoperating Income/(Expense) | 18,183 | 16,523 | 16,821 | 1,660 | 10.0% | 1,361 | 8.1% |
| Net Income/(Loss) before Capital Contributions | 11,216 | 129,725 | 208,174 | (118,508) | -91.4% | (196,957) | -94.6% |
| Capital Contributions | 200,820 | - | 705,138 | 200,820 | NM | (504,319) | -71.5% |
| Net Income/(Loss) | \$ 212,036 | \$ 129,725 | \$ 913,312 | \$ 82,311 | 63.5% | \$ (701,276) | -76.8% |
| Beginning Net Position | 22,769,384 | 22,066,444 | 19,303,791 | 702,941 | 3.2% | 3,465,593 | 18.0% |
| Change in Net Position | 212,036 | 129,725 | 913,312 | 82,311 | 63.5% | (701,276) | -76.8% |
| ENDING NET POSITION | \$ 22,981,420 | \$ 22,196,168 | \$ 20,217,103 | \$ 785,252 | 3.5% | \$ 2,764,317 | 13.7% |

fn1 Includes an adjustment to unbilled revenues of (\$5,304) in 2025 and \$11,031 for 2024

fn2 Includes an adjustment to unbilled revenues of \$7,421 in 2025 and \$10,840 for 2024

fn3 Includes an adjustment to unbilled revenues of (\$29) in 2025 and \$207 for 2024

Muscatine Power and Water - Communications Utility
Statements of Revenues, Expenses, and Changes in Net Position
Year To Date - December 2025

| Income Statement | Results | | | Variance | | | |
|---|----------------------|----------------------|----------------------|-------------------|--------------|---------------------|---------------|
| | Actual | Budget | Prior Year | Vs Budget \$ | % | Vs Prior Yr \$ | % |
| Operating Revenue | | | | | | | |
| Video ^{fn1} | \$ 5,568,031 | \$ 5,660,823 | \$ 5,970,861 | \$ (92,792) | -1.6% | \$ (402,830) | -6.7% |
| Data/Internet ^{fn2} | 7,957,910 | 8,042,865 | 8,090,254 | (84,954) | -1.1% | (132,344) | -1.6% |
| Enterprise | 971,990 | 774,000 | 903,674 | 197,990 | 25.6% | 68,316 | 7.6% |
| Phone ^{fn3} | 397,593 | 397,411 | 387,177 | 182 | 0.0% | 10,416 | 2.7% |
| Miscellaneous | 93,343 | 70,150 | 78,129 | 23,193 | 33.1% | 15,215 | 19.5% |
| Inter-Utility Revenue | 198,342 | 150,000 | 131,483 | 48,342 | 32.2% | 66,859 | 50.9% |
| Total Operating Revenue | 15,187,210 | 15,095,248 | 15,561,578 | 91,962 | 0.6% | (374,367) | -2.4% |
| Operating Expense | | | | | | | |
| Programming | 4,034,607 | 4,194,365 | 4,301,514 | 159,758 | 3.8% | 266,907 | 6.2% |
| Video Margin \$ | 1,533,424 | 1,466,458 | 1,669,347 | 66,966 | 4.6% | (135,923) | -8.1% |
| Video Margin % | 27.5% | 25.9% | 28.0% | | | | |
| Data Access Fees | 231,338 | 230,565 | 222,958 | (774) | -0.3% | (8,380) | -3.8% |
| Operations | 1,152,818 | 1,125,672 | 1,040,293 | (27,147) | -2.4% | (112,525) | -10.8% |
| Maintenance | 515,873 | 697,200 | 594,266 | 181,328 | 26.0% | 78,393 | 13.2% |
| Direct Labor | 2,032,206 | 1,804,251 | 1,866,417 | (227,956) | -12.6% | (165,789) | -8.9% |
| A&G Labor | 1,518,805 | 1,441,551 | 1,466,366 | (77,254) | -5.4% | (52,439) | -3.6% |
| A&G | 1,819,343 | 2,226,083 | 2,066,619 | 406,741 | 18.3% | 247,276 | 12.0% |
| Total Operating Expense | 11,304,989 | 11,719,686 | 11,558,433 | 414,697 | 3.5% | 253,444 | 2.2% |
| Operating Margin | 3,882,221 | 3,375,562 | 4,003,145 | 506,659 | 15.0% | (120,924) | -3.0% |
| Depreciation & Amortization | 1,753,530 | 1,594,770 | 2,666,959 | (158,760) | -10.0% | 913,429 | 34.2% |
| Operating Income | 2,128,691 | 1,780,792 | 1,336,186 | 347,899 | 19.5% | 792,505 | 59.3% |
| Nonoperating Income/(Expense) | | | | | | | |
| Interest Income | 384,992 | 311,696 | 460,058 | 73,297 | 23.5% | (75,065) | -16.3% |
| Interest Expense | (127,358) | (113,422) | (182,009) | (13,936) | -12.3% | 54,651 | 30.0% |
| Gain/(Loss) on Disposal of Assets | - | - | 8,667 | - | NM | (8,667) | NM |
| Net Nonoperating Income/(Expense) | 257,634 | 198,274 | 286,715 | 59,360 | 29.9% | (29,081) | -10.1% |
| Net Income/(Loss) before Capital Contributions | 2,386,325 | 1,979,065 | 1,622,901 | 407,259 | 20.6% | 763,424 | 47.0% |
| Capital Contributions | 377,993 | - | 711,138 | 377,993 | NM | (333,145) | -46.8% |
| Net Income/(Loss) | \$ 2,764,317 | \$ 1,979,065 | \$ 2,334,039 | \$ 785,252 | 39.7% | \$ 430,278 | 18.4% |
| Beginning Net Position | 20,217,103 | 20,217,103 | 17,883,064 | - | 0.0% | 2,334,039 | 13.1% |
| Change in Net Position | 2,764,317 | 1,979,065 | 2,334,039 | 785,252 | 39.7% | 430,278 | 18.4% |
| ENDING NET POSITION | \$ 22,981,420 | \$ 22,196,168 | \$ 20,217,103 | \$ 785,252 | 3.5% | \$ 2,764,317 | 13.7% |

fn1 Includes an adjustment to unbilled revenues of (\$5,304) in 2025 and \$11,031 for 2024

fn2 Includes an adjustment to unbilled revenues of \$7,421 in 2025 and \$10,840 for 2024

fn3 Includes an adjustment to unbilled revenues of (\$29) in 2025 and \$207 for 2024

Muscatine Power and Water - Communications Utility
Statements of Net Position
December 2025

| ASSETS | | | |
|---|----------------------|---------------------------|--------------------------|
| | <u>2025</u> | <u>Prior Month</u> | <u>Prior Year</u> |
| Current Assets | | | |
| Cash - Interest Bearing | \$ 1,884,072 | \$ 4,607,367 | \$ 2,693,887 |
| Investments | 5,750,000 | 5,750,000 | 6,050,000 |
| Receivables: | | | |
| Consumer Accounts | 1,992,094 | 1,881,791 | 2,498,027 |
| Interest | 135,180 | 115,905 | 167,449 |
| Inventories | 445,215 | 446,320 | 495,080 |
| Prepaid Expenses | 371,731 | 417,626 | 249,381 |
| Total Current Assets | 10,578,292 | 13,219,009 | 12,153,824 |
| Non-Current Assets Capital Assets | | | |
| Property, Plant & Equipment | 33,240,981 | 32,557,223 | 31,871,757 |
| Subscription-Based IT Assets | 605,637 | 605,637 | 523,037 |
| Construction Work in Progress | 536,395 | 1,170,610 | 563,081 |
| Less: Accumulated Depreciation | (17,080,458) | (16,896,535) | (15,326,927) |
| Total Capital Assets | 17,302,556 | 17,436,936 | 17,630,948 |
| Other Assets | | | |
| Net Pension Asset | - | - | - |
| Total Other Assets | - | - | - |
| Deferred Outflows of Resources | | | |
| Pension | 723,071 | 1,836,382 | 1,368,772 |
| OPEB | 91,116 | 29,253 | 35,121 |
| IPERS | 3,049 | 3,049 | 3,049 |
| Total Deferred Outflows of Resources | 817,236 | 1,868,684 | 1,406,941 |
| TOTAL ASSETS | \$ 28,698,084 | \$ 32,524,628 | \$ 31,191,713 |

Muscatine Power and Water - Communications Utility
Statements of Net Position
December 2025

| LIABILITIES AND NET POSITION | | | |
|--|----------------------|----------------------|----------------------|
| | 2025 | Prior Month | Prior Year |
| Current Liabilities | | | |
| <u>Payable from Unrestricted Assets</u> | | | |
| Accounts Payable | \$ 539,851 | \$ 532,781 | \$ 787,463 |
| Health & Dental Insurance Provision | 32,722 | 44,673 | 44,673 |
| Accrued Payroll | 113,602 | 64,750 | 78,252 |
| Accrued Compensated Absences | 354,975 | 357,802 | 343,696 |
| Accrued Property Taxes | 35,112 | 32,186 | 32,281 |
| Miscellaneous Accrued Expenses | 95,844 | 86,392 | 104,217 |
| Unearned Revenue | 17,500 | 17,500 | 17,500 |
| Total Payable from Unrestricted Assets | 1,189,605 | 1,136,083 | 1,408,082 |
| <u>Payable from Restricted Assets</u> | | | |
| Notes Payable: | | | |
| Revenue Bond | 1,159,310 | 1,540,547 | 1,509,510 |
| Electric Utility | - | 513,616 | - |
| Accrued Interest | - | 19,593 | - |
| Total Payable from Restricted Assets | 1,159,310 | 2,073,756 | 1,509,510 |
| Total Current Liabilities | 2,348,915 | 3,209,839 | 2,917,592 |
| Non-Current Liabilities | | | |
| Notes Payable: | | | |
| Revenue Bond | 1,570,722 | 1,570,722 | 2,730,032 |
| Electric Utility | - | 2,096,021 | 2,609,637 |
| Health & Dental Insurance Provision | 2,719 | 8,968 | 7,939 |
| Post-Employment Health Benefit Provision | 247,363 | 182,547 | 178,865 |
| Unearned Revenue | 71,980 | 73,438 | 89,480 |
| Subscription-Based IT Arrangements | 273,867 | 282,253 | 326,819 |
| Net Pension Liability | 616,448 | 1,723,032 | 1,501,549 |
| Total Non-Current Liabilities | 2,783,099 | 5,936,982 | 7,444,321 |
| Deferred Inflows of Resources | | | |
| Pension | 567,308 | 599,199 | 599,199 |
| OPEB | 15,920 | 7,802 | 12,077 |
| IPERS | 1,421 | 1,421 | 1,421 |
| Total Deferred Inflows of Resources | 584,649 | 608,422 | 612,697 |
| Net Position | | | |
| Net Investment in Capital Assets | 14,572,524 | 13,792,458 | 13,391,406 |
| Unrestricted | 8,408,896 | 8,976,927 | 6,825,697 |
| Total Net Position | 22,981,420 | 22,769,384 | 20,217,103 |
| TOTAL LIABILITIES AND NET POSITION | \$ 28,698,084 | \$ 32,524,628 | \$ 31,191,713 |

Muscatine Power and Water - Communications Utility
Statements of Cash Flows
December 2025

| | Month | Year To Date |
|---|---------------------|---------------------|
| Cash Flows from Operating Activities | | |
| Operating Margin | \$ 176,957 | \$ 3,882,221 |
| Change in Deferred Outflows of Resources | 1,051,448 | 589,705 |
| Change in Deferred Inflows of Resources | (23,773) | (28,048) |
| Changes in Assets and Liabilities: | | |
| Consumer Accounts Receivable | 90,516 | 883,926 |
| Inventories | 1,105 | 49,865 |
| Prepaid and Deferred Expenses | 45,895 | (122,350) |
| Accounts Payable | 7,070 | (247,612) |
| Retained Percentage on Contracts | - | - |
| Net Pension Liability | (1,106,585) | (885,101) |
| Health & Dental Insurance Provision | (18,200) | (17,171) |
| Other Post-Employment Benefit Provision | 64,816 | 68,498 |
| Accrued Payroll | 48,852 | 35,350 |
| Accrued Compensated Absences | (2,827) | 11,278 |
| Accrued Property Taxes | 2,926 | 2,832 |
| Unearned Revenue | (1,458) | (17,500) |
| Miscellaneous Accrued Expenses | 9,452 | (8,374) |
| Retained Percentage on Contracts | - | - |
| Net Cash Flows From Operating Activities | 346,193 | 4,197,519 |
| Cash Flows from Capital and Financing Activities: | | |
| Capital Expenditures | (58,950) | (1,492,026) |
| Gain/(Loss) on Disposal of Assets | - | - |
| Bond Issuance and Principal Payments - Net | (2,990,874) | (4,119,147) |
| Loan Interest Payments | (27,759) | (113,422) |
| Net Cash Flows from Capital & Financing Activities | (3,077,583) | (5,724,595) |
| Cash Flows from Investing Activities: | | |
| Interest Received on Investments | 8,095 | 417,261 |
| Net Cash Flows from Investing Activities | 8,095 | 417,261 |
| Net Increase/(Decrease) | (2,723,295) | (1,109,815) |
| Cash and Investments at Beginning of Period | 10,357,367 | 8,743,887 |
| Cash and Investments at End of Period | \$ 7,634,072 | \$ 7,634,072 |

Muscatine Power & Water - Communications Utility
Summary of Expense
Current Month - December 2025

| Summary of Expense | Results | | | Variance | | | |
|---|----------------|----------------|----------------|-----------------|---------------|-----------------|---------------|
| | Actual | Budget | Prior Year | Vs Budget \$ | % | Vs Prior Yr \$ | % |
| Video | | | | | | | |
| Program Acquisition Expense (751-758) | \$ 322,605 | \$ 334,692 | \$ 335,722 | \$ 12,088 | 3.6% | \$ 13,118 | 3.9% |
| Promotional Expense (960) | 407 | 685 | 463 | 279 | 40.7% | 57 | 12.2% |
| Electricity Expense (736) | - | - | - | - | NM | - | NM |
| Pole Attachment Expense (715) | 2,545 | 1,907 | 1,923 | (638) | -33.5% | (622) | -32.3% |
| Changes of Service (742) | - | - | - | - | NM | - | NM |
| Underground Line Expense (743) | 131 | 117 | 42 | (13) | -11.3% | (88) | -209.9% |
| Ad Insertion - Marketing/Production (964) | 9,240 | 10,042 | 9,111 | 802 | 8.0% | (129) | -1.4% |
| Miscellaneous Video Expense (710, 738-9) | 12,002 | 32,968 | 9,510 | 20,966 | 63.6% | (2,492) | -26.2% |
| Vehicle Expense (760) | 1,839 | 4,565 | 6,044 | 2,726 | 59.7% | 4,205 | 69.6% |
| Maintenance: | | | | | | | |
| Fiber (711) | 955 | 849 | 2,330 | (106) | -12.5% | 1,375 | 59.0% |
| Coax (712) | - | - | - | - | NM | - | NM |
| Drops (713) | - | 131 | 163 | 131 | NM | 163 | NM |
| Conduit System (714) | 940 | 180 | 972 | (760) | -422.1% | 32 | 3.3% |
| Network Operations Center (721-725) | 14,044 | 16,588 | 23,688 | 2,544 | 15.3% | 9,643 | 40.7% |
| Line Equipment (731-735) | - | - | 1,282 | - | NM | 1,282 | NM |
| Converters (741) | 573 | 292 | - | (281) | -96.3% | (573) | NM |
| Ad Insertion (966) | - | - | - | - | NM | - | NM |
| Property Taxes (794) | 1,287 | 1,184 | 1,184 | (104) | -8.8% | (104) | -8.8% |
| Video Labor | 75,548 | 74,381 | 73,742 | (1,167) | -1.6% | (1,806) | -2.4% |
| Total Video Expense | 442,115 | 478,582 | 466,175 | 36,467 | 7.6% | 24,060 | 5.2% |
| % of Operating Revenue | 35.0% | 38.5% | 34.5% | | | | |
| Internet | | | | | | | |
| Data/Internet Access Charges (851-853) | 18,183 | 19,214 | 12,518 | 1,031 | 5.4% | (5,664) | -45.2% |
| Promotional Expense (961) | 587 | 745 | 667 | 157 | 21.1% | 80 | 12.0% |
| Electricity Expense (836) | - | - | - | - | NM | - | NM |
| Pole Attachment Expense (837) | 3,798 | 2,118 | 2,137 | (1,679) | -79.3% | (1,661) | -77.7% |
| Underground Line Expense (843) | 196 | 240 | 65 | 44 | 18.2% | (131) | -201.5% |
| Miscellaneous Data/Internet Expense (839, 844, 848) | 13,420 | 10,545 | 11,928 | (2,875) | -27.3% | (1,491) | -12.5% |
| Internet Equipment (810) | 54,371 | 28,667 | 4,519 | (25,704) | -89.7% | (49,852) | NM |
| Vehicle Expense (860) | 1,350 | 1,300 | 1,678 | (50) | -3.9% | 328 | 19.5% |
| Maintenance: | | | | | | | |
| Fiber (811) | 2,746 | 1,079 | 4,476 | (1,668) | -154.6% | 1,730 | 38.6% |
| Coax (813) | - | - | - | - | NM | - | NM |
| Drops (814) | - | 268 | 333 | 268 | NM | 333 | NM |
| Conduit System (816) | 2,702 | 518 | 2,794 | (2,184) | -422.1% | 92 | 3.3% |
| Network Operations Center (820, 821) | 16,098 | 26,986 | 10,177 | 10,888 | 40.3% | (5,921) | -58.2% |
| Line Equipment (831-835) | - | - | 1,282 | - | NM | 1,282 | NM |
| ONT (841) | - | 417 | - | 417 | NM | - | NM |
| Property Taxes (894) | 1,404 | 1,291 | 1,291 | (113) | -8.8% | (113) | -8.8% |
| Internet Labor | 84,057 | 65,670 | 71,185 | (18,387) | -28.0% | (12,872) | -18.1% |
| Total Internet Expense | 198,912 | 159,055 | 125,051 | (39,856) | -25.1% | (73,861) | -59.1% |
| % of Operating Revenue | 15.7% | 12.8% | 9.2% | | | | |

Muscatine Power & Water - Communications Utility
Summary of Expense
Current Month - December 2025

| Summary of Expense | Results | | | Variance | | | |
|--|---------------------|-------------------|-------------------|--------------------|----------------|---------------------|----------------|
| | Actual | Budget | Prior Year | Vs Budget \$ | % | Vs Prior Yr \$ | % |
| Enterprise | | | | | | | |
| Pole Attachment Expense (838) | \$ 439 | \$ 492 | \$ 214 | 53 | 10.8% | (225) | -105.2% |
| Tools Expense (845) | 29 | - | 17 | (29) | NM | (12) | -73.5% |
| Misc Enterprise Expense (849) | 1,943 | 2,146 | 1,721 | 203 | 9.5% | (222) | -12.9% |
| Maintenance: | | | | | | | |
| Fiber (812) | 199 | 148 | 366 | (51) | -34.7% | 167 | 45.6% |
| Conduit System (817) | 196 | 38 | 202 | (158) | -422.1% | 7 | 3.3% |
| Enterprise Equipment (818, 819) | 2,858 | 9,083 | 2,815 | 6,226 | 68.5% | (43) | -1.5% |
| Property Taxes (896) | 205 | 188 | 188 | (16) | -8.8% | (17) | -8.8% |
| Enterprise Labor | 7,455 | 6,650 | 6,291 | (806) | -12.1% | (1,164) | -18.5% |
| Total Enterprise Expense | 13,323 | 18,745 | 11,814 | 5,422 | 28.9% | (1,509) | -12.8% |
| % of Operating Revenue | 1.1% | 1.5% | 0.9% | | | | |
| Phone | | | | | | | |
| Operating Expense (880) | 50,862 | 12,529 | 23,919 | (38,333) | -306.0% | (26,943) | -112.6% |
| Phone Labor | 2,714 | 5,437 | 2,218 | 2,723 | 50.1% | (496) | -22.4% |
| Total Phone Expense | 53,576 | 17,966 | 26,137 | (35,610) | -198.2% | (27,440) | -105.0% |
| % of Operating Revenue | 4.2% | 1.4% | 1.9% | | | | |
| Customer Information Expense (909) | 3,477 | 5,135 | 2,301 | 1,659 | 32.3% | (1,176) | -51.1% |
| % of Operating Revenue | 0.3% | 0.4% | 0.2% | | | | |
| Consumer Accounts & Records | | | | | | | |
| Consumer Records and Collections (903) | 18,624 | 12,987 | 13,867 | (5,637) | -43.4% | (4,757) | -34.3% |
| Uncollectible Accounts Expense (904) | 24,731 | 3,618 | 58,096 | (21,113) | -583.6% | 33,366 | 57.4% |
| Total Consumer Accounts & Records Expense | 43,355 | 16,605 | 71,963 | (26,750) | -161.1% | 28,609 | 39.8% |
| % of Operating Revenue | 3.4% | 1.3% | 5.3% | | | | |
| Administrative & General | | | | | | | |
| Office Supplies and Expense (921) | 11,003 | 7,839 | 1,764 | (3,164) | -40.4% | (9,238) | -523.6% |
| Outside Services Employed (923) | 14,630 | 23,469 | (355) | 8,838 | 37.7% | (14,986) | NM |
| Property Insurance (924) | 2,653 | 6,364 | 3,011 | 3,711 | 58.3% | 359 | 11.9% |
| Casualty Ins, Injuries & Damages (925) | 6,473 | 11,062 | 13,432 | 4,590 | 41.5% | 6,959 | 51.8% |
| Employee Benefits (926) | 89,056 | 71,149 | 30,076 | (17,907) | -25.2% | (58,980) | -196.1% |
| Employee Pensions (926-PEN) | 17,344 | 32,693 | 21,784 | 15,349 | 46.9% | 4,440 | 20.4% |
| Fringe Benefits Charges to Construction (927) | (6,979) | (5,833) | (8,702) | 1,145 | 19.6% | (1,723) | -19.8% |
| Rents (931) | 12,107 | 12,107 | 11,754 | (0) | 0.0% | (353) | -3.0% |
| Miscellaneous General Expense (930) | 12,201 | 15,233 | 7,479 | 3,032 | 19.9% | (4,722) | -63.1% |
| A&G Adder (930-AGA) | 24,359 | (6,667) | - | (31,026) | NM | (24,359) | NM |
| Maintenance of General Plant (932) | 11,433 | 11,915 | 9,571 | 483 | 4.1% | (1,862) | -19.5% |
| A&G Labor | 137,792 | 121,982 | 128,626 | (15,809) | -13.0% | (9,166) | -7.1% |
| Total Administrative & General Expense | 332,072 | 301,312 | 218,440 | (30,760) | -10.2% | (113,632) | -52.0% |
| % of Operating Revenue | 26.3% | 24.2% | 16.1% | | | | |
| TOTAL OPERATING EXPENSE | \$ 1,086,829 | \$ 997,401 | \$ 921,881 | \$ (89,429) | -9.0% | \$ (164,949) | -17.9% |
| % of Operating Revenue | 86.0% | 80.2% | 68.2% | | | | |
| Depreciation | | | | | | | |
| Video Depreciation (793) | 29,236 | 16,524 | 34,852 | (12,712) | -76.9% | 5,616 | 16.1% |
| Internet Depreciation (893) | 117,415 | 81,969 | 169,131 | (35,445) | -43.2% | 51,717 | 30.6% |
| Enterprise Depreciation (840) | 7,583 | 7,649 | 7,644 | 65 | 0.9% | 61 | 0.8% |
| A&G Depreciation (933) | 18,803 | 18,437 | 18,468 | (366) | -2.0% | (334) | -1.8% |
| Subscription-Based IT Arrangements Amort (428) | 10,887 | 8,070 | 9,357 | (2,817) | -34.9% | (1,530) | -16.3% |
| Total Depreciation | \$ 183,923 | \$ 132,649 | \$ 239,453 | \$ (51,274) | -38.7% | \$ 55,530 | 23.2% |
| % of Operating Revenue | 14.6% | 10.7% | 17.7% | | | | |

Muscatine Power & Water - Communications Utility
Summary of Expense
Year To Date - December 2025

| Summary of Expense | Results | | | Variance | | | |
|---|------------------|------------------|------------------|------------------|--------------|------------------|---------------|
| | Actual | Budget | Prior Year | Vs Budget \$ | % | Vs Prior Yr \$ | % |
| Video | | | | | | | |
| Program Acquisition Expense (751-758) | \$ 4,034,607 | \$ 4,194,365 | \$ 4,301,514 | \$ 159,758 | 3.8% | \$ 266,907 | 6.2% |
| Promotional Expense (960) | 3,710 | 8,224 | 1,660 | 4,514 | 54.9% | (2,049) | -123.4% |
| Electricity Expense (736) | - | - | - | - | NM | - | NM |
| Pole Attachment Expense (715) | 23,698 | 22,879 | 23,095 | (819) | -3.6% | (603) | -2.6% |
| Changes of Service (742) | - | - | - | - | NM | - | NM |
| Underground Line Expense (743) | 1,254 | 1,409 | 2,112 | 154 | 10.9% | 857 | 40.6% |
| Ad Insertion - Marketing/Production (964) | 90,269 | 120,500 | 130,598 | 30,231 | 25.1% | 40,329 | 30.9% |
| Miscellaneous Video Expense (710, 738-9) | 131,473 | 147,262 | 141,849 | 15,789 | 10.7% | 10,376 | 7.3% |
| Vehicle Expense (760) | 32,622 | 51,593 | 70,953 | 18,971 | 36.8% | 38,331 | 54.0% |
| Maintenance: | | | | | | | |
| Fiber (711) | 8,233 | 13,590 | 15,887 | 5,357 | 39.4% | 7,654 | 48.2% |
| Coax (712) | - | - | 640 | - | NM | 640 | NM |
| Drops (713) | 3,869 | 2,096 | 3,493 | (1,773) | -84.6% | (376) | -10.8% |
| Conduit System (714) | 4,585 | 2,880 | 3,699 | (1,705) | -59.2% | (886) | -24.0% |
| Network Operations Center (721-725) | 177,918 | 200,896 | 251,788 | 22,978 | 11.4% | 73,870 | 29.3% |
| Line Equipment (731-735) | 6,797 | - | 15,379 | (6,797) | NM | 8,582 | 55.8% |
| Converters (741) | (4,576) | 3,500 | (2,451) | 8,076 | NM | 2,125 | 86.7% |
| Ad Insertion (966) | - | - | - | - | NM | - | NM |
| Property Taxes (794) | 16,073 | 14,203 | 15,628 | (1,870) | -13.2% | (444) | -2.8% |
| Video Labor | 920,681 | 881,612 | 911,695 | (39,069) | -4.4% | (8,986) | -1.0% |
| Total Video Expense | 5,451,212 | 5,665,008 | 5,887,539 | 213,795 | 3.8% | 436,327 | 7.4% |
| <i>% of Operating Revenue</i> | 35.9% | 37.5% | 37.8% | | | | |
| Internet | | | | | | | |
| Data/Internet Access Charges (851-853) | 231,338 | 230,565 | 222,958 | (774) | -0.3% | (8,380) | -3.8% |
| Promotional Expense (961) | 5,832 | 8,934 | 3,690 | 3,102 | 34.7% | (2,142) | -58.0% |
| Electricity Expense (836) | - | - | - | - | NM | - | NM |
| Pole Attachment Expense (837) | 27,305 | 25,421 | 25,661 | (1,884) | -7.4% | (1,644) | -6.4% |
| Underground Line Expense (843) | 1,954 | 2,880 | 3,613 | 926 | 32.2% | 1,659 | 45.9% |
| Miscellaneous Data/Internet Expense (839, 844, 848) | 145,709 | 158,051 | 181,909 | 12,343 | 7.8% | 36,201 | 19.9% |
| Internet Equipment (810) | 386,744 | 344,000 | 220,291 | (42,744) | -12.4% | (166,454) | -75.6% |
| Vehicle Expense (860) | 14,174 | 15,198 | 19,027 | 1,024 | 6.7% | 4,853 | 25.5% |
| Maintenance: | | | | | | | |
| Fiber (811) | 13,208 | 17,259 | 29,639 | 4,051 | 23.5% | 16,430 | 55.4% |
| Coax (813) | - | - | 783 | - | NM | 783 | NM |
| Drops (814) | 9,077 | 4,285 | 6,540 | (4,791) | -111.8% | (2,537) | -38.8% |
| Conduit System (816) | 13,181 | 8,280 | 10,633 | (4,901) | -59.2% | (2,548) | -24.0% |
| Network Operations Center (820, 821) | 215,988 | 327,450 | 159,068 | 111,462 | 34.0% | (56,920) | -35.8% |
| Line Equipment (831-835) | 6,836 | - | 15,379 | (6,836) | NM | 8,543 | 55.5% |
| Modems (841) | - | 5,000 | - | 5,000 | NM | - | NM |
| Property Taxes (894) | 17,533 | 15,495 | 17,049 | (2,038) | -13.2% | (484) | -2.8% |
| Internet Labor | 956,590 | 779,501 | 875,086 | (177,089) | -22.7% | (81,504) | -9.3% |
| Total Internet Expense | 2,045,469 | 1,942,320 | 1,791,325 | (103,149) | -5.3% | (254,144) | -14.2% |
| <i>% of Operating Revenue</i> | 13.5% | 12.9% | 11.5% | | | | |

Muscatine Power & Water - Communications Utility
Summary of Expense
Year To Date - December 2025

| Summary of Expense | Results | | | Variance | | | |
|--|----------------------|----------------------|----------------------|---------------------|---------------|-------------------|---------------|
| | Actual | Budget | Prior Year | Vs Budget \$ | % | Vs Prior Yr \$ | % |
| Enterprise | | | | | | | |
| Pole Attachment Expense (838) | \$ 2,793 | \$ 5,908 | \$ 2,766 | 3,115 | 52.7% | (27) | -1.0% |
| Tools Expense (845) | 94 | - | 219 | (94) | NM | 124 | 56.8% |
| Misc Enterprise Expense (849) | 32,243 | 29,933 | 17,453 | (2,311) | -7.7% | (14,791) | -84.7% |
| Maintenance: | | | | | | | |
| Fiber (812) | 1,209 | 2,364 | 2,479 | 1,156 | 48.9% | 1,270 | 51.2% |
| Conduit System (817) | 955 | 600 | 771 | (355) | -59.2% | (185) | -24.0% |
| Enterprise Equipment (818, 819) | 58,592 | 109,000 | 80,540 | 50,408 | 46.2% | 21,948 | 27.3% |
| Property Taxes (896) | 2,557 | 2,260 | 2,486 | (297) | -13.1% | (71) | -2.8% |
| Enterprise Labor | 80,105 | 78,964 | 75,468 | (1,141) | -1.4% | (4,637) | -6.1% |
| Total Enterprise Expense | 178,549 | 229,029 | 182,181 | 50,480 | 22.0% | 3,632 | 2.0% |
| % of Operating Revenue | 1.2% | 1.5% | 1.2% | | | | |
| Phone | | | | | | | |
| Operating Expense (880) | 216,781 | 151,522 | 160,236 | (65,259) | -43.1% | (56,545) | -35.3% |
| Phone Labor | 74,831 | 64,174 | 4,167 | (10,656) | -16.6% | (70,663) | NM |
| Total Phone Expense | 291,611 | 215,696 | 164,403 | (75,916) | -35.2% | (127,209) | -77.4% |
| % of Operating Revenue | 1.9% | 1.4% | 1.1% | | | | |
| Customer Information Expense (909) | 40,397 | 65,222 | 29,238 | 24,826 | 38.1% | (11,158) | -38.2% |
| % of Operating Revenue | 0.3% | 0.4% | 0.2% | | | | |
| Consumer Accounts & Records | | | | | | | |
| Consumer Records and Collections (903) | 126,691 | 157,246 | 154,286 | 30,555 | 19.4% | 27,595 | 17.9% |
| Uncollectible Accounts Expense (904) | 103,869 | 43,414 | 108,380 | (60,455) | -139.3% | 4,510 | 4.2% |
| Total Consumer Accounts & Records Expense | 230,560 | 200,660 | 262,666 | (29,900) | -14.9% | 32,105 | 12.2% |
| % of Operating Revenue | 1.5% | 1.3% | 1.7% | | | | |
| Administrative & General | | | | | | | |
| Office Supplies and Expense (921) | 58,128 | 50,837 | 48,339 | (7,291) | -14.3% | (9,789) | -20.3% |
| Outside Services Employed (923) | 124,845 | 144,541 | 105,283 | 19,696 | 13.6% | (19,562) | -18.6% |
| Property Insurance (924) | 25,185 | 56,828 | 28,582 | 31,643 | 55.7% | 3,397 | 11.9% |
| Casualty Ins, Injuries & Damages (925) | 110,084 | 128,901 | 119,431 | 18,817 | 14.6% | 9,347 | 7.8% |
| Employee Benefits (926) | 943,913 | 854,221 | 840,648 | (89,692) | -10.5% | (103,265) | -12.3% |
| Employee Pensions (926-PEN) | 238,828 | 392,315 | 322,525 | 153,487 | 39.1% | 83,697 | 26.0% |
| Fringe Benefits Charged to Construction | (63,111) | (70,000) | (90,022) | (6,889) | -9.8% | (26,912) | -29.9% |
| Rents (931) | 145,283 | 145,283 | 141,051 | (0) | 0.0% | (4,232) | -3.0% |
| Miscellaneous General Expense (930) | 151,459 | 196,620 | 150,870 | 45,162 | 23.0% | (588) | -0.4% |
| A&G Adder (930-AGA) | (284,243) | (80,000) | (1,699) | 204,243 | 255.3% | 282,544 | NM |
| Maintenance of General Plant (932) | 98,014 | 140,654 | 109,706 | 42,639 | 30.3% | 11,692 | 10.7% |
| A&G Labor | 1,518,805 | 1,441,551 | 1,466,366 | (77,254) | -5.4% | (52,439) | -3.6% |
| Total Administrative & General Expense | 3,067,191 | 3,401,752 | 3,241,081 | 334,561 | 9.8% | 173,890 | 5.4% |
| % of Operating Revenue | 20.2% | 22.5% | 20.8% | | | | |
| TOTAL OPERATING EXPENSE | \$ 11,304,989 | \$ 11,719,686 | \$ 11,558,433 | \$ 414,697 | 3.5% | \$ 253,444 | 2.2% |
| % of Operating Revenue | 74.4% | 77.6% | 74.3% | | | | |
| Depreciation | | | | | | | |
| Video Depreciation (793) | 238,650 | 198,288 | 276,114 | (40,363) | -20.4% | 37,464 | 13.6% |
| Internet Depreciation (893) | 1,090,074 | 983,634 | 1,976,464 | (106,440) | -10.8% | 886,390 | 44.8% |
| Enterprise Depreciation (840) | 90,997 | 91,783 | 91,728 | 786 | 0.9% | 730 | 0.8% |
| A&G Depreciation (933) | 210,266 | 221,242 | 213,752 | 10,976 | 5.0% | 3,486 | 1.6% |
| Subscription-Based IT Arrangements Amort (428) | 123,542 | 99,824 | 108,901 | (23,718) | -23.8% | (14,641) | -13.4% |
| Total Depreciation | \$ 1,753,530 | \$ 1,594,770 | \$ 2,666,959 | \$ (158,760) | -10.0% | \$ 913,429 | 34.2% |
| % of Operating Revenue | 11.5% | 10.6% | 17.1% | | | | |

Muscatine Power and Water - Communications Utility
Subscribers
December 2025

| Subscribers | Results | | | Variance | | | |
|----------------------------|---------------|---------------|---------------|--------------|--------------|--------------|--------------|
| | Actual | Budget | Prior Year | Vs Budget | % | Vs Prior Yr | % |
| Video | | | | | | | |
| Residential | 2,743 | 2,740 | 2,923 | 3 | 0.1% | (180) | -6.2% |
| Residential Bulk | 256 | 254 | 298 | 2 | 0.8% | (42) | -14.1% |
| Commercial/Hospitality | 96 | 96 | 104 | - | 0.0% | (8) | -7.7% |
| Commercial Bulk | 283 | 283 | 283 | - | 0.0% | - | 0.0% |
| Total Video | 3,378 | 3,373 | 3,608 | 5 | 0.1% | (230) | -6.4% |
| Data/Internet | | | | | | | |
| Residential | 9,454 | 9,570 | 9,623 | (116) | -1.2% | (169) | -1.8% |
| Commercial | 727 | 715 | 729 | 12 | 1.7% | (2) | -0.3% |
| Total Data/Internet | 10,181 | 10,285 | 10,352 | (104) | -1.0% | (171) | -1.7% |
| Phone | | | | | | | |
| Residential | 496 | 475 | 508 | 21 | 4.4% | (12) | -2.4% |
| Commercial/Enterprise | 800 | 630 | 570 | 170 | 27.0% | 230 | 40.4% |
| Total Phone | 1,296 | 1,105 | 1,078 | 191 | 17.3% | 218 | 20.2% |
| Enterprise | | | | | | | |
| MAN | 38 | 36 | 40 | 2 | 5.6% | (2) | -5.0% |
| MDC | 43 | 43 | 39 | - | 0.0% | 4 | 10.3% |
| Leased Fiber | 29 | 28 | 25 | 1 | 3.6% | 4 | 16.0% |
| Total Enterprise | 110 | 107 | 104 | 3 | 2.8% | 6 | 5.8% |



City of Muscatine

ITEM NUMBER 2026-0032

AGENDA ITEM SUMMARY

DATE: 2/3/2026

STAFF

Mike Hartman, Fire Chief

SUBJECT

Request to Approve Mutual Aid Agreement with Wilton Fire Department

EXECUTIVE SUMMARY

Presented for City Council's consideration is a request to enter into an agreement that will allow the Muscatine Fire Department (MFD) to respond to fires at Muscatine Power and Water (MPW) properties as part of the initial emergency response.

STAFF RECOMMENDATION

It is recommended that the agreement is approved

BACKGROUND/DISCUSSION

Muscatine Power and Water has a few facilities that are located outside Muscatine city limits. A fire at one of these facilities has the potential to impact utility service to citizens of Muscatine. MFD is presently responding to the initial call for incidents at MPW properties in the Fruitland Fire District, through our current Automatic Aid agreement. Approval of this agreement will allow MFD to respond to the initial call for any MPW property that is in the Wilton Fire District. Presently, this consists of a substation on Highway 38, north of Muscatine. Approval of the agreement will provide quicker response and less damage should an incident occur. Damage to the MPW properties outside the City can have a negative impact on individuals and companies who are within city limits. Over the past ten years, there has been one minor fire-related call, so there would be little to no impact on call volume. The Wilton Fire Department verbally approved the agreement and MPW staff are supportive of this change.

CITY FINANCIAL IMPACT

There is little to no expected economic impact based on the historic call volume to this location.

ATTACHMENTS

1. Wilton FD Auto Aid for MPW Locations (1)

AUTOMATIC MUTUAL AID AGREEMENT
WILTON FIRE DISTRICT – MUSCATINE POWER & WATER

Section 1. This agreement is made pursuant to Chapter 28E of the Code of Iowa between the Wilton Fire District and the City of Muscatine, in regards to the provision of fire suppression services, as provided for by the respective fire departments.

Section 2. Duration. This agreement shall remain in effect until either party serves notice to the other party that it intends to terminate the agreement, on a particular date specified in the notice.

Section 3. Purpose. The purpose of this agreement is to provide for the response of the personnel and equipment from the Fire Department of one party to fire suppression within the jurisdiction of the other party.

Section 4. Expenses. Each jurisdiction shall assume all of its own operating expenses incurred which relate to the response to emergencies under this agreement. These expenses include, but are not limited to, salaries, compensation, equipment costs, and fuel expenses. This provision shall apply unless prior arrangements to the contrary have been made.

Section 5. Liability. Each jurisdiction shall be solely liable for any damage or injury which its personnel, property, or equipment may suffer while responding to, working at, or returning from the other jurisdiction.

Section 6. Administration. The Fire Chief of each jurisdiction shall act as co-administrators of this agreement.

All decisions pertaining to the acquisition, maintenance, and disposal of any real or personal property jointly obtained as a consequence of this agreement shall be made by the co-administrators, or their designated representatives. Disposition of any jointly acquired property shall be made prior to termination of the agreement by either party.

Section 7. Procedures. The "Automatic Mutual Aid" area will include the property owned by Muscatine Power and Water. Upon notification of a fire in this area of the first party's jurisdiction, the second party will be notified of said emergency. If circumstances allow, based upon the discretion of the second party, the second party may respond personnel and equipment to the emergency.

Other areas of each jurisdiction are considered "Mutual Aid Areas", where assistance is provided when normal resources available to the jurisdiction are exceeded by an emergency situation.

Section 8. Responsibility. It is not the intent of this agreement to create a responsibility upon either party to respond to, continue a response to, or maintain a presence at the scene of any emergency occurring within the jurisdiction of the other party.

Executed on the dates as indic

Wilton Fire Department

City of Muscatine

By: _____
Mayor, City of Wilton, IA

By: _____
Mayor, City of Muscatine, IA

Attest:

Wilton Fire Chief

Muscatine City Clerk

Date: _____

Date: _____



City of Muscatine

ITEM NUMBER 2026-0039

AGENDA ITEM SUMMARY

DATE: 2/3/2026

STAFF

Brian Stineman, Public Works Director
Kevin Coon, City Engineer

SUBJECT

Request to Approve the Issuance of a Purchase Order in the Amount of \$13,800.00 to Muscatine County Abstract for Property Title Searches on the West Hill Sewer Separation Phase 6E Project.

EXECUTIVE SUMMARY

For council consideration is a request to approve a purchase order in the amount of \$13,800.00 to Muscatine County Abstract for property title searches on the West Hill Sewer Separation Phase 6E Project.

STAFF RECOMMENDATION

Staff recommends approval of the request.

BACKGROUND/DISCUSSION

This purchase order is for a professional service to provide property title reports on properties that require easements on the West Hill Phase 6E Project. This is the second step in the easement process and is needed to verify property details such as liens, interested parties, existing easements, etc. Muscatine County Abstract is currently the only local option for completing this work.

CITY FINANCIAL IMPACT

Funds are available through the Local Option Sales Tax and State Revolving Fund.

ATTACHMENTS

Accounts Payable

Transactions by Account

User: SMeyer
 Printed: 01/29/2026 - 1:12PM
 Batch: 00008.01.2026



City of
MUSCATINE
 City Hall
 215 Sycamore St
 Muscatine, Iowa 52761
www.muscatineiowa.gov
 (563) 264-1550

| Account Number | Vendor | Description | GL Date | Check No | Amount | PO No |
|--------------------|------------------------------|---------------------------------------|------------|----------|----------|-------|
| 1000-00-0000-23150 | ILLINOIS DEPARTMENT OF REVEN | PR Batch 00002.01.2026 State Income T | 01/16/2026 | 0 | 331.60 | |
| 1000-00-0000-23150 | ILLINOIS DEPARTMENT OF REVEN | PR Batch 00001.01.2026 State Income T | 01/02/2026 | 0 | 357.54 | |
| 1000-00-0000-23150 | ILLINOIS DEPARTMENT OF REVEN | PR Batch 00003.01.2026 State Income T | 01/30/2026 | 0 | 356.12 | |
| | | Vendor Subtotal: | | | 1,045.26 | |
| 1000-01-1131-61340 | CIVICPLUS | See Click Fix | 01/29/2026 | 0 | 7,089.27 | |
| | | Vendor Subtotal: | | | 7,089.27 | |
| 1000-01-1131-69400 | GREATER MUSCATINE CHAMBER | Jan - Jun Dues | 01/29/2026 | 0 | 102.50 | |
| | | Vendor Subtotal: | | | 102.50 | |
| 1000-01-1132-61550 | ROCK VALLEY PHYSICAL THERAP | Pre-Employment - A Phillips-Derengows | 01/28/2026 | 0 | 140.00 | |
| | | Vendor Subtotal: | | | 140.00 | |
| 1000-01-1132-62530 | CROSSROADS INC. | Shredding | 01/29/2026 | 0 | 22.00 | |
| | | Vendor Subtotal: | | | 22.00 | |
| 1000-01-1144-52840 | DRJ GROUP, LLC | First Aid Cabinet | 01/28/2026 | 0 | 17.42 | |
| | | Vendor Subtotal: | | | 17.42 | |
| 1000-01-1144-61550 | GENESIS HEALTH SYSTEM-OCC HI | Randoms - S Wheeler | 01/28/2026 | 0 | 40.00 | |
| | | Vendor Subtotal: | | | 40.00 | |

| | | | | | |
|--------------------|------------------------------|------------------------|------------|---|-----------------|
| 1000-05-1141-51300 | AMAZON.COM | Drum Cartridge | 01/28/2026 | 0 | 53.90 |
| | | Vendor Subtotal: | | | 53.90 |
| 1000-05-1141-65100 | QUAD CITY TIMES & MUSC JOURN | Minutes 1/13/26 | 01/29/2026 | 0 | 33.52 |
| 1000-05-1141-65100 | QUAD CITY TIMES & MUSC JOURN | Minutes 1/13/26 | 01/29/2026 | 0 | 15.73 |
| 1000-05-1141-65100 | QUAD CITY TIMES & MUSC JOURN | City Wages | 01/29/2026 | 0 | 220.25 |
| | | Vendor Subtotal: | | | 269.50 |
| 1000-05-1143-51100 | LUPTON & TOYNE PRINTERS | City Window Envelopes | 01/28/2026 | 0 | 116.00 00032704 |
| | | Vendor Subtotal: | | | 116.00 |
| 1000-05-1143-61550 | GENESIS HEALTH SYSTEM-OCC HI | New Hire - R Hammond | 01/28/2026 | 0 | 40.00 |
| | | Vendor Subtotal: | | | 40.00 |
| 1000-05-1145-69200 | UNITED STATES POSTAL SERVICE | Postage | 01/29/2026 | 0 | 5,000.00 |
| | | Vendor Subtotal: | | | 5,000.00 |
| 1000-05-1146-51400 | AMAZON.COM | Power Y Cable | 01/29/2026 | 0 | 41.90 |
| | | Vendor Subtotal: | | | 41.90 |
| 1000-05-1146-52890 | AMAZON.COM | UniFi Access Point | 01/29/2026 | 0 | 162.00 |
| | | Vendor Subtotal: | | | 162.00 |
| 1000-05-1146-65240 | MUSCATINE POWER & WATER | December Internet - PW | 01/29/2026 | 0 | 387.00 |
| | | Vendor Subtotal: | | | 387.00 |
| 1000-10-1221-51300 | AMAZON.COM | Cardstock Paper | 01/29/2026 | 0 | 18.49 |
| | | Vendor Subtotal: | | | 18.49 |

| | | | | | |
|--------------------|------------------------------|---|------------|---|-------------------|
| 1000-10-1221-52890 | SHERWIN WILLIAMS | Anti-Graffiti Sealant for Houser St Mural | 01/29/2026 | 0 | 465.77 00032164 |
| | | Vendor Subtotal: | | | 465.77 |
| 1000-10-1221-61340 | POINT & PAY LLC | December Service Fee | 01/29/2026 | 0 | 15.00 |
| | | Vendor Subtotal: | | | 15.00 |
| 1000-10-1221-62310 | XEROX CORPORATION | Copier | 01/29/2026 | 0 | 27.58 |
| 1000-10-1221-62310 | XEROX CORPORATION | Copier | 01/29/2026 | 0 | 0.13 |
| | | Vendor Subtotal: | | | 27.71 |
| 1000-10-1221-62470 | KELLOR & KELLOR LANDSCAPE I | Nuisance Abatement - 511 Main | 01/29/2026 | 0 | 91.00 |
| 1000-10-1221-62470 | KELLOR & KELLOR LANDSCAPE I | Nuisance Abatement - 1507 Lucas | 01/29/2026 | 0 | 91.00 |
| 1000-10-1221-62470 | KELLOR & KELLOR LANDSCAPE I | Nuisance Abatement - 322 Main | 01/29/2026 | 0 | 446.25 |
| 1000-10-1221-62470 | KELLOR & KELLOR LANDSCAPE I | Nuisance Abatement - 411 McArthur | 01/29/2026 | 0 | 168.00 |
| 1000-10-1221-62470 | KELLOR & KELLOR LANDSCAPE I | Nuisance Abatement - 218 Walnut | 01/29/2026 | 0 | 143.50 |
| 1000-10-1221-62470 | KELLOR & KELLOR LANDSCAPE I | Nuisance Abatement - 1303 Hershey | 01/29/2026 | 0 | 84.00 |
| 1000-10-1221-62470 | KELLOR & KELLOR LANDSCAPE I | Nuisance Abatement - 909 Mulberry | 01/29/2026 | 0 | 38.50 |
| | | Vendor Subtotal: | | | 1,062.25 |
| 1000-10-1221-62470 | A NOTCH ABOVE TREE SERVICE | 314 Green St - Remove Nuisance Tree | 01/29/2026 | 0 | 1,320.00 00032382 |
| | | Vendor Subtotal: | | | 1,320.00 |
| 1000-10-1221-65100 | QUAD CITY TIMES & MUSC JOURN | ZBA Legal Notice | 01/29/2026 | 0 | 29.41 |
| | | Vendor Subtotal: | | | 29.41 |
| 1000-10-1221-68200 | BI-STATE REGIONAL COMMISSION | Bi State Dues | 01/29/2026 | 0 | 2,880.25 |
| | | Vendor Subtotal: | | | 2,880.25 |
| 1000-10-1221-69800 | POINT & PAY LLC | December CC Fees | 01/29/2026 | 0 | 786.10 |
| | | Vendor Subtotal: | | | 786.10 |

| | | | | | |
|--------------------|---------------------------|-------------------------------------|------------|---|-----------|
| 1000-15-1311-61520 | UNITY HEALTHCARE-HOSPITAL | Medical C Bell | 01/28/2026 | 0 | 41,688.50 |
| 1000-15-1311-61520 | UNITY HEALTHCARE-HOSPITAL | Medical C Bell | 01/28/2026 | 0 | 11,850.99 |
| | | Vendor Subtotal: | | | 53,539.49 |
| 1000-15-1311-62530 | STERICYCLE INC | Shredding | 01/28/2026 | 0 | 49.86 |
| | | Vendor Subtotal: | | | 49.86 |
| 1000-15-1311-65210 | MUSCATINE POWER & WATER | December Phones - PSB | 01/28/2026 | 0 | 46.00 |
| | | Vendor Subtotal: | | | 46.00 |
| 1000-20-1321-51100 | AMAZON.COM | Coupler Adapter | 01/28/2026 | 0 | 6.99 |
| 1000-20-1321-51100 | AMAZON.COM | Desk Lamp | 01/29/2026 | 0 | 34.99 |
| | | Vendor Subtotal: | | | 41.98 |
| 1000-20-1321-52890 | MENARDS (MUSC) | Bracket/Safety Hasp/Carpet Adhesive | 01/28/2026 | 0 | 25.58 |
| 1000-20-1321-52890 | MENARDS (MUSC) | Broom/Dustpan | 01/28/2026 | 0 | 14.58 |
| | | Vendor Subtotal: | | | 40.16 |
| 1000-20-1321-52890 | AMAZON.COM | Input/Output Cable | 01/29/2026 | 0 | 17.50 |
| | | Vendor Subtotal: | | | 17.50 |
| 1000-20-1321-53220 | FELD FIRE | Shipping for SCBA Parts | 01/28/2026 | 0 | 76.49 |
| | | Vendor Subtotal: | | | 76.49 |
| 1000-20-1321-61520 | EQUIAN LLC | Medical Fee J Hall DOS 9/20/25 | 01/28/2026 | 0 | 1.03 |
| | | Vendor Subtotal: | | | 1.03 |
| 1000-20-1321-61520 | HY-VEE, INC. | Prescription | 01/28/2026 | 0 | 18.99 |
| 1000-20-1321-61520 | HY-VEE, INC. | Prescription | 01/28/2026 | 0 | 18.99 |

| | | | | | |
|--------------------|---------------------------|--|------------|------------------|----------|
| | | | | Vendor Subtotal: | 37.98 |
| 1000-20-1321-61520 | TMESYS LLC | Prescription - K McCarthy | 01/28/2026 | 0 | 444.19 |
| 1000-20-1321-61520 | TMESYS LLC | Prescription - T Eagle | 01/28/2026 | 0 | 250.06 |
| 1000-20-1321-61520 | TMESYS LLC | Prescription - K McCarthy | 01/28/2026 | 0 | 210.34 |
| 1000-20-1321-61520 | TMESYS LLC | Prescription - M Collins | 01/28/2026 | 0 | 95.32 |
| 1000-20-1321-61520 | TMESYS LLC | Prescription - J Barnhart | 01/28/2026 | 0 | 396.97 |
| | | | | Vendor Subtotal: | 1,396.88 |
| 1000-20-1321-61550 | EQUIAN LLC | Medical Fee J Hall DOS 9/20/25 | 01/29/2026 | 0 | 262.50 |
| | | | | Vendor Subtotal: | 262.50 |
| 1000-20-1321-61560 | UI HEALTH CARE MED CENTER | Medical J Hall DOS 9/24/25 Code: 7104 | 01/28/2026 | 0 | 414.15 |
| 1000-20-1321-61560 | UI HEALTH CARE MED CENTER | Medical J Hall DOS 9/24/25 Code: 9330 | 01/28/2026 | 0 | 4,118.69 |
| 1000-20-1321-61560 | UI HEALTH CARE MED CENTER | Medical J Hall DOS 9/20/25 Code: 7104: | 01/28/2026 | 0 | 36.90 |
| 1000-20-1321-61560 | UI HEALTH CARE MED CENTER | Medical J Hall DOS 9/16/25 Code: 7417 | 01/29/2026 | 0 | 656.10 |
| 1000-20-1321-61560 | UI HEALTH CARE MED CENTER | Medical J Hall DOS 10/16/25 Code: 992 | 01/29/2026 | 0 | 152.94 |
| 1000-20-1321-61560 | UI HEALTH CARE MED CENTER | Medical J Hall DOS 10/16/25 Code: G22 | 01/29/2026 | 0 | 43.26 |
| | | | | Vendor Subtotal: | 5,422.04 |
| 1000-20-1321-61560 | EQUIAN LLC | Medical Fee J Hall DOS 9/24/25 | 01/28/2026 | 0 | 0.82 |
| 1000-20-1321-61560 | EQUIAN LLC | Medical Fee M Fleming DOS 12/18/25 | 01/28/2026 | 0 | 10.01 |
| 1000-20-1321-61560 | EQUIAN LLC | Medical Fee J Hall DOS 9/30/25 | 01/29/2026 | 0 | 31.25 |
| 1000-20-1321-61560 | EQUIAN LLC | Medical Fee J Hall DOS 9/16/25 | 01/29/2026 | 0 | 18.23 |
| 1000-20-1321-61560 | EQUIAN LLC | Medical Fee J Hall DOS 9/17/25 | 01/29/2026 | 0 | 18.75 |
| 1000-20-1321-61560 | EQUIAN LLC | Medical Fee J Hall DOS 10/16/25 | 01/29/2026 | 0 | 5.46 |
| | | | | Vendor Subtotal: | 84.52 |
| 1000-20-1321-61560 | ORA ORTHOPEDICS PC | Medical M Fleming DOS 12/18/25 Code | 01/28/2026 | 0 | 367.35 |
| 1000-20-1321-61560 | ORA ORTHOPEDICS PC | Medical M Fleming DOS 12/18/25 Code | 01/28/2026 | 0 | 119.97 |
| 1000-20-1321-61560 | ORA ORTHOPEDICS PC | Medical M Fleming DOS 12/18/25 Code | 01/28/2026 | 0 | 44.64 |
| | | | | Vendor Subtotal: | 531.96 |
| 1000-20-1321-61660 | UNITY HEALTHCARE-HOSPITAL | Medical A Sink DOS 1/9/25 Code: 93011 | 01/28/2026 | 0 | 1,502.96 |

| | | | | | |
|--------------------|-------------------------------|---------------------------------------|------------------|---|-----------------|
| | | | Vendor Subtotal: | | 1,502.96 |
| 1000-20-1321-62210 | PHELPS THE UNIFORM SPECIALIST | Laundry - Fire | 01/29/2026 | 0 | 32.39 |
| | | | Vendor Subtotal: | | 32.39 |
| 1000-20-1321-64200 | SEAN PAUSTIAN | Reimb for Craft/Culture Class Fees | 01/28/2026 | 0 | 225.00 |
| | | | Vendor Subtotal: | | 225.00 |
| 1000-20-1321-65240 | MUSCATINE POWER & WATER | December Phones - PSB | 01/28/2026 | 0 | 42.79 |
| | | | Vendor Subtotal: | | 42.79 |
| 1000-20-1321-67130 | SKM, LLC | Emergency Repair | 01/28/2026 | 0 | 973.40 |
| | | | Vendor Subtotal: | | 973.40 |
| 1000-20-1321-67130 | CURRY'S RD TRUCK & TRAILER RE | Waste | 01/29/2026 | 0 | 6.95 00032701 |
| 1000-20-1321-67130 | CURRY'S RD TRUCK & TRAILER RE | Air Bag | 01/29/2026 | 0 | 566.79 00032701 |
| 1000-20-1321-67130 | CURRY'S RD TRUCK & TRAILER RE | Air Bag Weathered and Leaking Air Rer | 01/29/2026 | 0 | 128.00 00032701 |
| 1000-20-1321-67130 | CURRY'S RD TRUCK & TRAILER RE | Misc Shop Supplies | 01/29/2026 | 0 | 12.80 00032701 |
| | | | Vendor Subtotal: | | 714.54 |
| 1000-20-1321-67130 | RELIANT FIRE APPARATUS | Emergency Repairs #311 | 01/29/2026 | 0 | 4,271.88 |
| 1000-20-1321-67130 | RELIANT FIRE APPARATUS | Emergency Repairs #311 | 01/29/2026 | 0 | 3,798.73 |
| 1000-20-1321-67130 | RELIANT FIRE APPARATUS | Emergency Repairs #312 | 01/29/2026 | 0 | 1,360.82 |
| | | | Vendor Subtotal: | | 9,431.43 |
| 1000-20-1321-67320 | FELD FIRE | SCBA Mask Repair - J. Colon | 01/29/2026 | 0 | 146.02 00032509 |
| | | | Vendor Subtotal: | | 146.02 |
| 1000-20-1321-69400 | FIRE SERVICE TRAINING BUREAU | HMA/HMO - T Davis | 01/28/2026 | 0 | 100.00 |

| | | | | | |
|--------------------|-------------------------------|--------------------------------|------------------|---|-----------------|
| | | | Vendor Subtotal: | | 100.00 |
| 1000-25-1115-61520 | HY-VEE | FLU SHOT CLINIC | 01/28/2026 | 0 | 560.00 00032044 |
| | | | Vendor Subtotal: | | 560.00 |
| 1000-25-1411-62210 | PHELPS THE UNIFORM SPECIALIST | Laundry - Greenwood | 01/28/2026 | 0 | 13.53 |
| | | | Vendor Subtotal: | | 13.53 |
| 1000-25-1411-64500 | JENNIFER EAGLE | July thru December Mileage | 01/29/2026 | 0 | 48.20 |
| | | | Vendor Subtotal: | | 48.20 |
| 1000-25-1411-64500 | BRIANNE MURPHY | June - December Mileage | 01/29/2026 | 0 | 53.55 |
| | | | Vendor Subtotal: | | 53.55 |
| 1000-25-1411-65310 | ALLIANT ENERGY | December Gas - Greenwood | 01/28/2026 | 0 | 528.04 |
| | | | Vendor Subtotal: | | 528.04 |
| 1000-25-1421-51300 | AMAZON.COM | 106R03692 YELLOW EXTRA HIGH C. | 01/28/2026 | 0 | 198.88 00032716 |
| | | | Vendor Subtotal: | | 198.88 |
| 1000-25-1423-52400 | MENARDS (MUSC) | Dish Soap | 01/29/2026 | 0 | 13.96 |
| 1000-25-1423-52400 | MENARDS (MUSC) | Steel Pads/Kitchen Brush | 01/28/2026 | 0 | 12.68 |
| | | | Vendor Subtotal: | | 26.64 |
| 1000-25-1423-52740 | ARNOLD MOTOR SUPPLY | Oil | 01/28/2026 | 0 | 15.72 |
| | | | Vendor Subtotal: | | 15.72 |
| 1000-25-1423-52750 | MENARDS (MUSC) | Bar Oil | 01/29/2026 | 0 | 8.49 |

| | | | | | |
|--------------------|-------------------------------|-----------------------|------------------|---|-----------------|
| | | | Vendor Subtotal: | | 8.49 |
| 1000-25-1423-52890 | MENARDS (MUSC) | Pail/Hand Towels | 01/28/2026 | 0 | 12.29 |
| | | | Vendor Subtotal: | | 12.29 |
| 1000-25-1423-53110 | PLUMB SUPPLY COMPANY | FURNACE CONTROL BOARD | 01/29/2026 | 0 | 193.68 00032728 |
| | | | Vendor Subtotal: | | 193.68 |
| 1000-25-1423-53120 | VAN METER INDUSTRIAL INC | Weatherproof Cover | 01/28/2026 | 0 | 22.46 |
| | | | Vendor Subtotal: | | 22.46 |
| 1000-25-1423-53130 | GRAINGER DEPT 802675066 | Sewer Nozzle | 01/28/2026 | 0 | 26.51 |
| | | | Vendor Subtotal: | | 26.51 |
| 1000-25-1423-53130 | MENARDS (MUSC) | Strainer/PVC Snap | 01/28/2026 | 0 | 16.03 |
| 1000-25-1423-53130 | MENARDS (MUSC) | Tubing/Washer | 01/28/2026 | 0 | 22.79 |
| | | | Vendor Subtotal: | | 38.82 |
| 1000-25-1423-53220 | ARNOLD MOTOR SUPPLY | Filters | 01/28/2026 | 0 | 25.62 |
| | | | Vendor Subtotal: | | 25.62 |
| 1000-25-1423-53220 | AMAZON.COM | FS 91R FILTER KIT | 01/28/2026 | 0 | 7.99 00032663 |
| 1000-25-1423-53220 | AMAZON.COM | KM 94R FILTER KIT | 01/28/2026 | 0 | 24.69 00032663 |
| 1000-25-1423-53220 | AMAZON.COM | MTANLO TUNE UP KITS | 01/28/2026 | 0 | 58.14 00032663 |
| 1000-25-1423-53220 | AMAZON.COM | HONEYRAIN TUNE UP KIT | 01/28/2026 | 0 | 9.49 00032663 |
| 1000-25-1423-53220 | AMAZON.COM | Filter | 01/28/2026 | 0 | 24.95 |
| | | | Vendor Subtotal: | | 125.26 |
| 1000-25-1423-62210 | PHELPS THE UNIFORM SPECIALIST | Laundry - Weed Park | 01/29/2026 | 0 | 14.40 |
| 1000-25-1423-62210 | PHELPS THE UNIFORM SPECIALIST | Laundry - Weed Park | 01/28/2026 | 0 | 35.40 |

| | | | | | |
|--------------------|------------------------------|---------------------------------------|------------------|---|-----------------|
| | | | Vendor Subtotal: | | 49.80 |
| 1000-25-1423-62450 | A TECH/FREEMAN ALARM | Security 2/1/26 - 4/30/26 | 02/01/2026 | 0 | 116.97 |
| | | | Vendor Subtotal: | | 116.97 |
| 1000-25-1423-65310 | ALLIANT ENERGY | December Gas - Pearl City | 01/28/2026 | 0 | 380.68 |
| 1000-25-1423-65310 | ALLIANT ENERGY | December Gas - Harbor | 01/28/2026 | 0 | 436.53 |
| | | | Vendor Subtotal: | | 817.21 |
| 1000-25-1423-67130 | MUSCATINE LUMBER | Keys | 01/28/2026 | 0 | 4.99 |
| | | | Vendor Subtotal: | | 4.99 |
| 1000-25-1423-67140 | A-1 QUALITY TIRE & CAR CARE | MOUNT/DISMOUNT | 01/29/2026 | 0 | 27.00 00032772 |
| 1000-25-1423-67140 | A-1 QUALITY TIRE & CAR CARE | VALVE STEM | 01/29/2026 | 0 | 5.00 00032772 |
| 1000-25-1423-67140 | A-1 QUALITY TIRE & CAR CARE | 27x9R14 MUD-TERRAIN TIRE | 01/29/2026 | 0 | 420.00 00032772 |
| | | | Vendor Subtotal: | | 452.00 |
| 1000-25-1424-53220 | MENARDS (MUSC) | Pin Wrench/Blade Kit/Wipes | 01/29/2026 | 0 | 39.68 |
| | | | Vendor Subtotal: | | 39.68 |
| 1000-25-1424-61550 | GENESIS HEALTH SYSTEM-OCC HI | New Hire Drug Screen - D Kreuzenstein | 01/28/2026 | 0 | 40.00 |
| | | | Vendor Subtotal: | | 40.00 |
| 1000-25-1424-62450 | A TECH/FREEMAN ALARM | January Alarms | 01/29/2026 | 0 | 25.33 |
| 1000-25-1424-62450 | A TECH/FREEMAN ALARM | Security 2/1/26 - 4/30/26 | 02/01/2026 | 0 | 131.97 |
| 1000-25-1424-62450 | A TECH/FREEMAN ALARM | Security 2/1/26 - 4/30/26 | 02/01/2026 | 0 | 119.97 |
| 1000-25-1424-62450 | A TECH/FREEMAN ALARM | Security 2/1/26 - 4/30/26 | 02/01/2026 | 0 | 119.97 |
| 1000-25-1424-62450 | A TECH/FREEMAN ALARM | January Alarms | 01/29/2026 | 0 | 10.13 |
| 1000-25-1424-62450 | A TECH/FREEMAN ALARM | January Alarms | 01/29/2026 | 0 | 31.99 |
| | | | Vendor Subtotal: | | 439.36 |

| | | | | | |
|--------------------|----------------------------|-----------------------------|------------|---|-----------------|
| 1000-25-1424-64200 | IOWA TURFGRASS OFFICE | Conference - D Kreuzenstein | 01/28/2026 | 0 | 285.00 |
| | | Vendor Subtotal: | | | 285.00 |
| 1000-25-1424-65210 | CENTURYLINK | January Phones - Kent Stein | 01/28/2026 | 0 | 101.98 |
| | | Vendor Subtotal: | | | 101.98 |
| 1000-25-1425-62130 | FREERS & SONS TREE SERVICE | REMOVE BROKEN BRANCH FROM ' | 01/28/2026 | 0 | 200.00 00032664 |
| | | Vendor Subtotal: | | | 200.00 |
| 1000-25-1427-52750 | CARQUEST OF MUSCATINE | Oil | 01/28/2026 | 0 | 62.00 |
| | | Vendor Subtotal: | | | 62.00 |
| 1000-25-1427-53210 | ARNOLD MOTOR SUPPLY | Filter | 01/28/2026 | 0 | 19.51 |
| | | Vendor Subtotal: | | | 19.51 |
| 1000-25-1427-53210 | MENARDS (MUSC) | Spike/Glove/Blade/Hammer | 01/28/2026 | 0 | 98.56 |
| | | Vendor Subtotal: | | | 98.56 |
| 1000-25-1427-53220 | ARNOLD MOTOR SUPPLY | Taper Bearing Cone/Cup | 01/29/2026 | 0 | 33.68 |
| 1000-25-1427-53220 | ARNOLD MOTOR SUPPLY | Taper Bearing Cone/Cup | 01/29/2026 | 0 | 33.68 |
| | | Vendor Subtotal: | | | 67.36 |
| 1000-25-1427-53220 | MOTION INDUSTRIES INC | Bearing Cones/Cups | 01/29/2026 | 0 | 93.08 |
| | | Vendor Subtotal: | | | 93.08 |
| 1000-25-1427-53220 | MTI DISTRIBUTING INC | DECK PARTS | 01/28/2026 | 0 | 319.44 00032675 |
| 1000-25-1427-53220 | MTI DISTRIBUTING INC | 4700 PIN | 01/28/2026 | 0 | 160.00 00032675 |
| 1000-25-1427-53220 | MTI DISTRIBUTING INC | SHIPPING | 01/28/2026 | 0 | 30.96 00032675 |
| | | Vendor Subtotal: | | | 510.40 |

| | | | | | |
|--------------------|-------------------------------|--|------------|---|-----------------|
| 1000-25-1427-53220 | AMAZON.COM | Adjustable Variable Pin Spanner Wrench | 01/28/2026 | 0 | 47.90 |
| | | Vendor Subtotal: | | | 47.90 |
| 1000-25-1427-62210 | PHELPS THE UNIFORM SPECIALIST | Laundry - Soccer | 01/28/2026 | 0 | 25.11 |
| | | Vendor Subtotal: | | | 25.11 |
| 1000-25-1427-62450 | A TECH/FREEMAN ALARM | Security 2/1/26 - 4/30/26 | 02/01/2026 | 0 | 131.97 |
| 1000-25-1427-62450 | A TECH/FREEMAN ALARM | Security 2/1/26 - 4/30/26 | 02/01/2026 | 0 | 134.97 |
| 1000-25-1427-62450 | A TECH/FREEMAN ALARM | January Alarms | 01/29/2026 | 0 | 35.99 |
| 1000-25-1427-62450 | A TECH/FREEMAN ALARM | January Alarms | 01/29/2026 | 0 | 12.79 |
| | | Vendor Subtotal: | | | 315.72 |
| 1000-25-1427-64200 | IOWA TURFGRASS OFFICE | Conference - C Hull | 01/28/2026 | 0 | 285.00 |
| | | Vendor Subtotal: | | | 285.00 |
| 1000-25-1427-65210 | VERIZON WIRELESS | December Cell Phones | 01/28/2026 | 0 | 40.01 |
| | | Vendor Subtotal: | | | 40.01 |
| 1000-25-1428-38620 | STEPHANIE ANDERSON | Refund | 01/28/2026 | 0 | 300.00 |
| | | Vendor Subtotal: | | | 300.00 |
| 1000-25-1435-52400 | MENARDS (MUSC) | Wipes/Recycle Bags/Flap Tie Waste | 01/29/2026 | 0 | 37.82 |
| | | Vendor Subtotal: | | | 37.82 |
| 1000-25-1435-52890 | MENARDS (MUSC) | Driveway Marker/Shovel | 01/29/2026 | 0 | 270.96 |
| | | Vendor Subtotal: | | | 270.96 |
| 1000-25-1435-53210 | AMAZON.COM | FILTER KING 16X25X2 AIR FILTERS | 01/29/2026 | 0 | 322.96 00032725 |

| | | | | | |
|--------------------|--------------------------|--|------------------|---|-----------------|
| | | | Vendor Subtotal: | | 322.96 |
| 1000-25-1435-65210 | CLEARFLY | November Phones | 01/29/2026 | 0 | 79.31 |
| 1000-25-1435-65210 | CLEARFLY | Decenber Phones | 01/29/2026 | 0 | 61.68 |
| 1000-25-1435-65210 | CLEARFLY | January Phones | 01/29/2026 | 0 | 62.27 |
| | | | Vendor Subtotal: | | 203.26 |
| 1000-25-1435-65310 | ALLIANT ENERGY | December Gas - Dome | 01/29/2026 | 0 | 13,632.46 |
| | | | Vendor Subtotal: | | 13,632.46 |
| 1000-30-1511-51300 | AMAZON.COM | CF411X HP #410X Cyan Toner Cartridg | 01/29/2026 | 0 | 244.59 00032739 |
| | | | Vendor Subtotal: | | 244.59 |
| 1000-30-1511-52890 | AMAZON.COM | Cork Boards | 01/28/2026 | 0 | 29.99 |
| 1000-30-1511-52890 | AMAZON.COM | Envelopes | 01/29/2026 | 0 | 7.75 |
| 1000-30-1511-52890 | AMAZON.COM | Removable Tape Rollls | 01/29/2026 | 0 | 30.45 |
| | | | Vendor Subtotal: | | 68.19 |
| 1000-30-1511-62460 | AMAZON.COM | Craft Linoleum Cutter Kit Carving Tool | 01/29/2026 | 0 | 86.99 |
| 1000-30-1511-62460 | AMAZON.COM | Book Club - Dear Edward | 01/29/2026 | 0 | 143.64 |
| 1000-30-1511-62460 | AMAZON.COM | Rubber Carving Blocks | 01/29/2026 | 0 | 80.28 |
| | | | Vendor Subtotal: | | 310.91 |
| 1000-30-1511-62460 | GOOD KARMA CREATIONS | Materials for Bracelets | 01/29/2026 | 0 | 400.00 |
| | | | Vendor Subtotal: | | 400.00 |
| 1000-30-1511-69400 | ROTARY CLUB OF MUSCATINE | Dues - R Fiedler | 01/28/2026 | 0 | 164.00 |
| | | | Vendor Subtotal: | | 164.00 |
| 1000-30-1511-74500 | AMAZON.COM | Book Order | 01/28/2026 | 0 | 703.74 |
| 1000-30-1511-74500 | AMAZON.COM | Book Order | 01/29/2026 | 0 | 67.64 |

| | | | | | |
|--------------------|------------------------------|-------------------------------------|------------|---|-----------------|
| 1000-30-1511-74500 | AMAZON.COM | Book Order | 01/29/2026 | 0 | 50.04 |
| 1000-30-1511-74500 | AMAZON.COM | Book Order | 01/29/2026 | 0 | 123.28 |
| | | Vendor Subtotal: | | | 944.70 |
| 1000-30-1511-74500 | LIBRARY SYSTEMS & SERVICES | L Library Books/Materials | 01/28/2026 | 0 | 3,279.57 |
| | | Vendor Subtotal: | | | 3,279.57 |
| 1000-35-1521-61550 | ROCK VALLEY PHYSICAL THERAPY | Pre-Employment - A Matjucha-Hovland | 01/28/2026 | 0 | 140.00 |
| | | Vendor Subtotal: | | | 140.00 |
| 1000-40-1151-52300 | DAVID SCHRIER | Reimb Shoes - D Schrier | 01/28/2026 | 0 | 75.00 |
| | | Vendor Subtotal: | | | 75.00 |
| 1000-40-1151-52400 | MENARDS (MUSC) | Pine Cleaner | 01/28/2026 | 0 | 59.92 |
| 1000-40-1151-52400 | MENARDS (MUSC) | Swiffer | 01/28/2026 | 0 | 20.25 |
| 1000-40-1151-52400 | MENARDS (MUSC) | Cascade | 01/28/2026 | 0 | 36.45 |
| 1000-40-1151-52400 | MENARDS (MUSC) | Ajax | 01/28/2026 | 0 | 70.42 |
| 1000-40-1151-52400 | MENARDS (MUSC) | Stain Remover | 01/28/2026 | 0 | 8.82 |
| | | Vendor Subtotal: | | | 195.86 |
| 1000-40-1151-52830 | MENARDS (MUSC) | Compact 6 Elm Infrared Heater | 01/28/2026 | 0 | 143.97 00032792 |
| | | Vendor Subtotal: | | | 143.97 |
| 1000-40-1151-52890 | ARNOLD MOTOR SUPPLY | Fitting/Tape | 01/29/2026 | 0 | 27.52 |
| | | Vendor Subtotal: | | | 27.52 |
| 1000-40-1151-52890 | MENARDS (MUSC) | AAA Batteries - 24 pk | 01/28/2026 | 0 | 15.49 00032792 |
| 1000-40-1151-52890 | MENARDS (MUSC) | Salt Pellets | 01/28/2026 | 0 | 23.96 |
| 1000-40-1151-52890 | MENARDS (MUSC) | Batteries | 01/28/2026 | 0 | 11.04 |
| 1000-40-1151-52890 | MENARDS (MUSC) | Acid | 01/28/2026 | 0 | 45.85 |
| | | Vendor Subtotal: | | | 96.34 |

| | | | | | | |
|--------------------|-----------------------------|--|------------|---|-------------------|----------|
| 1000-40-1151-53120 | MENARDS (MUSC) | Wire Range | 01/29/2026 | 0 | 14.80 | |
| | | | | | Vendor Subtotal: | 14.80 |
| 1000-40-1151-53130 | MENARDS (MUSC) | Pipe Cap | 01/28/2026 | 0 | 1.69 | |
| 1000-40-1151-53130 | MENARDS (MUSC) | Pipe/Fittings | 01/28/2026 | 0 | 34.59 | |
| 1000-40-1151-53130 | MENARDS (MUSC) | Ball Valve | 01/28/2026 | 0 | 10.19 | |
| | | | | | Vendor Subtotal: | 46.47 |
| 1000-40-1151-53150 | MENARDS (MUSC) | Filter | 01/28/2026 | 0 | 39.84 | |
| | | | | | Vendor Subtotal: | 39.84 |
| 1000-40-1151-62450 | A TECH/FREEMAN ALARM | Security 2/1/26 - 4/30/26 | 02/01/2026 | 0 | 84.00 | |
| | | | | | Vendor Subtotal: | 84.00 |
| 1000-40-1151-65310 | ALLIANT ENERGY | December Gas - Art Center | 01/29/2026 | 0 | 1,123.82 | |
| 1000-40-1151-65310 | ALLIANT ENERGY | December Gas - Fire Lot 8 | 01/29/2026 | 0 | 117.66 | |
| 1000-40-1151-65310 | ALLIANT ENERGY | December Gas - City Hall | 01/29/2026 | 0 | 1,431.60 | |
| 1000-40-1151-65310 | ALLIANT ENERGY | December Gas - PSB | 01/29/2026 | 0 | 60.25 | |
| | | | | | Vendor Subtotal: | 2,733.33 |
| 1000-40-1151-67330 | MUSCATINE POWER & WATER | December Internet - PSB | 01/28/2026 | 0 | 82.97 | |
| | | | | | Vendor Subtotal: | 82.97 |
| 1000-40-1151-67330 | PEARL CITY MAINTENANCE LLC | Electrical and Heat Tape to Gutter and D | 01/28/2026 | 0 | 6,383.18 00032521 | |
| | | | | | Vendor Subtotal: | 6,383.18 |
| 1000-40-1151-67330 | CONSOLIDATED ELECTRICAL DIS | Generator | 01/29/2026 | 0 | 520.00 | |
| | | | | | Vendor Subtotal: | 520.00 |
| 1000-40-1611-52890 | MENARDS (MUSC) | Frame/Brush/Tray | 01/28/2026 | 0 | 86.56 | |

| | | | | | | |
|--------------------|-------------------------|--|------------|---|-------------------------|------------|
| | | | | | Vendor Subtotal: | 86.56 |
| 1000-40-1611-61660 | BOLTON & MENK INC | Traffic Signal Timing on Mississippi Dri | 01/28/2026 | 0 | 250.00 | 00032092 |
| | | | | | Vendor Subtotal: | 250.00 |
| 1000-40-1621-52300 | LOGEN CONKLIN | Reimb | 01/29/2026 | 0 | 102.16 | |
| | | | | | Vendor Subtotal: | 102.16 |
| 1000-40-1621-65275 | MIDWEST WIRELESS LLC | Radio | 01/29/2026 | 0 | 510.30 | |
| | | | | | Vendor Subtotal: | 510.30 |
| 1000-40-1624-52860 | IOWA PRISON INDUSTRIES | Replacement Street Marker Signs - Oakl | 01/28/2026 | 0 | 106.80 | 00032539 |
| 1000-40-1624-52860 | IOWA PRISON INDUSTRIES | Clay Signs | 01/29/2026 | 0 | 96.60 | |
| | | | | | Vendor Subtotal: | 203.40 |
| 1000-40-1641-62370 | MARCO | Copier | 01/28/2026 | 0 | 122.55 | |
| | | | | | Vendor Subtotal: | 122.55 |
| 1000-40-1641-65210 | MUSCATINE POWER & WATER | December Phones - PW | 01/29/2026 | 0 | 22.54 | |
| 1000-40-1641-65210 | MUSCATINE POWER & WATER | December Phones - PW | 01/29/2026 | 0 | 43.59 | |
| | | | | | Vendor Subtotal: | 66.13 |
| | | | | | Subtotal for FUND: 1000 | 133,961.78 |
| 3981-30-3981-62460 | THE T.A.G. ART COMPANY | Dinosuars at the Dome | 01/29/2026 | 0 | 3,337.50 | |
| | | | | | Vendor Subtotal: | 3,337.50 |
| | | | | | Subtotal for FUND: 3981 | 3,337.50 |
| 4158-40-4158-61660 | BOLTON & MENK INC | Oregon Trail Railroad Crossing | 01/28/2026 | 0 | 193.00 | |

| | | | | | |
|--------------------|----------------------------------|---------------------------------------|------------|-------------------------|------------|
| | | | | Vendor Subtotal: | 193.00 |
| | | | | Subtotal for FUND: 4158 | 193.00 |
| 4180-40-4180-61220 | LAW OFFICES OF HOPKINS & HUBBARD | December Legal - Houser & Fulliam Rot | 01/29/2026 | 0 | 1,125.00 |
| | | | | Vendor Subtotal: | 1,125.00 |
| | | | | Subtotal for FUND: 4180 | 1,125.00 |
| 4195-40-4199-61420 | BOLTON & MENK INC | Carver Corner Roundabout | 01/28/2026 | 0 | 189,016.50 |
| | | | | Vendor Subtotal: | 189,016.50 |
| | | | | Subtotal for FUND: 4195 | 189,016.50 |
| 4207-50-4207-61420 | BRADLEY W ROETH | Engineering | 01/29/2026 | 0 | 1,875.00 |
| | | | | Vendor Subtotal: | 1,875.00 |
| 4207-50-4207-73900 | KEOKUK CONTRACTORS | Houser Street Lift Station Pay App #4 | 01/29/2026 | 0 | 95,572.85 |
| 4207-50-4207-73900 | KEOKUK CONTRACTORS | Retainage Withheld | 01/29/2026 | 0 | -2,347.30 |
| | | | | Vendor Subtotal: | 93,225.55 |
| | | | | Subtotal for FUND: 4207 | 95,100.55 |
| 4276-40-4276-61420 | STANLEY CONSULTANTS INC | WHSSP Phase #6 | 01/29/2026 | 0 | 100,676.00 |
| | | | | Vendor Subtotal: | 100,676.00 |
| 4276-40-4276-73100 | KE FLATWORK INC | WHSSP Phase 6D Pay App 14 | 01/28/2026 | 0 | 209,465.42 |
| | | | | Vendor Subtotal: | 209,465.42 |

| | | | | | |
|--------------------|-----------------------------|------------------------------------|-------------------------|---|------------|
| | | | Subtotal for FUND: 4276 | | 310,141.42 |
| 4554-10-4554-61660 | CORNERSTONE COMMERCIAL CO | 201 Shoring Rental | 01/28/2026 | 0 | 752.00 |
| 4554-10-4554-61660 | CORNERSTONE COMMERCIAL CO | 203 Shoring Rental | 01/28/2026 | 0 | 828.00 |
| | | | Vendor Subtotal: | | 1,580.00 |
| | | | Subtotal for FUND: 4554 | | 1,580.00 |
| 5211-40-5211-51100 | AMAZON.COM | Click Pens | 01/28/2026 | 0 | 35.39 |
| 5211-40-5211-51100 | AMAZON.COM | Supplies | 01/29/2026 | 0 | 20.97 |
| | | | Vendor Subtotal: | | 56.36 |
| 5211-40-5211-52300 | MAGALY HERNANDEZ | Reimb Uniforms - M Hernandez | 01/28/2026 | 0 | 75.00 |
| | | | Vendor Subtotal: | | 75.00 |
| 5211-40-5211-52300 | EFRAIN MONTES | Reimb Uniforms - E Montes | 01/29/2026 | 0 | 75.00 |
| | | | Vendor Subtotal: | | 75.00 |
| 5211-40-5211-52400 | AMAZON.COM | Disinfectant Spray/Letter Stickers | 01/29/2026 | 0 | 38.78 |
| | | | Vendor Subtotal: | | 38.78 |
| 5211-40-5211-52890 | MENARDS (MUSC) | Lysol/Whisk Broom | 01/28/2026 | 0 | 28.77 |
| 5211-40-5211-52890 | MENARDS (MUSC) | Broom/Flex Tub/Basket | 01/29/2026 | 0 | 79.60 |
| | | | Vendor Subtotal: | | 108.37 |
| 5211-40-5211-61550 | ROCK VALLEY PHYSICAL THERAP | Pre-Employment - T Nickols | 01/28/2026 | 0 | 160.00 |
| 5211-40-5211-61550 | ROCK VALLEY PHYSICAL THERAP | Pre-Employment - R Hill | 01/28/2026 | 0 | 160.00 |
| 5211-40-5211-61550 | ROCK VALLEY PHYSICAL THERAP | Pre-Employment - M Peniston | 01/28/2026 | 0 | 160.00 |
| | | | Vendor Subtotal: | | 480.00 |

| | | | | | |
|--------------------|-------------------------|--|------------|---|-------------------|
| 5211-40-5211-62320 | SYCAMORE PRINTING INC | Blue Shuttle Tickets 18501 to 20000 | 01/29/2026 | 0 | 183.90 00032617 |
| 5211-40-5211-62320 | SYCAMORE PRINTING INC | Blue Shuttle Tickets 18501 to 20000 | 01/29/2026 | 0 | 0.10 |
| | | Vendor Subtotal: | | | 184.00 |
| 5211-40-5211-65275 | MIDWEST WIRELESS LLC | Radio | 01/29/2026 | 0 | 264.60 |
| | | Vendor Subtotal: | | | 264.60 |
| 5211-40-5211-74100 | CHRISTEN K HETZLER | Signage for New Buses Replacing 253 & | 01/28/2026 | 0 | 2,300.00 00032467 |
| | | Vendor Subtotal: | | | 2,300.00 |
| | | Subtotal for FUND: 5211 | | | 3,582.11 |
| 5311-05-5311-51100 | LUPTON & TOYNE PRINTERS | City Window Envelopes | 01/28/2026 | 0 | 116.00 00032704 |
| | | Vendor Subtotal: | | | 116.00 |
| 5311-05-5311-52890 | POM INCORPORATED | #300-756 - Battery Pack 6V AA Alkaline | 01/28/2026 | 0 | 638.00 00032221 |
| | | Vendor Subtotal: | | | 638.00 |
| 5311-05-5311-53220 | POM INCORPORATED | Shipping | 01/28/2026 | 0 | 125.00 |
| 5311-05-5311-53220 | POM INCORPORATED | #108-346 - #25 Long Vault Key (Quote # | 01/28/2026 | 0 | 129.50 00032221 |
| 5311-05-5311-53220 | POM INCORPORATED | #108-347 - #40 Short Upper Housing Ke | 01/28/2026 | 0 | 120.00 00032221 |
| | | Vendor Subtotal: | | | 374.50 |
| 5311-05-5311-61330 | NET TECH SOLUTIONS | Software 1/15/26 - 1/14/27 | 01/28/2026 | 0 | 1,575.00 |
| | | Vendor Subtotal: | | | 1,575.00 |
| 5311-05-5311-67320 | POM INCORPORATED | #102-652 - Dome Lenses (Quote #40132 | 01/28/2026 | 0 | 155.00 00032221 |
| | | Vendor Subtotal: | | | 155.00 |
| 5311-05-5311-74200 | POM INCORPORATED | CFG-APME-0040132-002 - APME Mecl | 01/28/2026 | 0 | 1,962.00 00032221 |

| | | | | | |
|--------------------|--------------------------|-----------------------------------|------------|---|-------------------|
| 5311-05-5311-74200 | POM INCORPORATED | CFG-APME-0040132-001 - 2 HR Meter | 01/28/2026 | 0 | 3,270.00 00032221 |
| | | Vendor Subtotal: | | | 5,232.00 |
| | | Subtotal for FUND: 5311 | | | 8,090.50 |
| 5451-25-5451-52890 | MENARDS (MUSC) | Tower Heater | 01/28/2026 | 0 | 25.49 |
| | | Vendor Subtotal: | | | 25.49 |
| 5451-25-5451-53110 | MENARDS (MUSC) | Air Wick/Filter | 01/28/2026 | 0 | 67.03 |
| | | Vendor Subtotal: | | | 67.03 |
| 5451-25-5451-53120 | MENARDS (MUSC) | Bulbs | 01/29/2026 | 0 | 131.88 |
| | | Vendor Subtotal: | | | 131.88 |
| 5451-25-5451-53120 | VAN METER INDUSTRIAL INC | Wire Connectors | 01/28/2026 | 0 | 33.92 |
| | | Vendor Subtotal: | | | 33.92 |
| 5451-25-5451-53140 | MENARDS (MUSC) | Paint Brush/Thinner | 01/28/2026 | 0 | 36.76 |
| | | Vendor Subtotal: | | | 36.76 |
| 5451-25-5451-53220 | ARNOLD MOTOR SUPPLY | Filter | 01/28/2026 | 0 | 8.90 |
| | | Vendor Subtotal: | | | 8.90 |
| 5451-25-5451-53220 | MTI DISTRIBUTING INC | SHIM | 01/29/2026 | 0 | 15.00 00032773 |
| 5451-25-5451-53220 | MTI DISTRIBUTING INC | SPINDLE | 01/29/2026 | 0 | 160.00 00032773 |
| 5451-25-5451-53220 | MTI DISTRIBUTING INC | SHIPPING | 01/29/2026 | 0 | 25.00 00032773 |
| 5451-25-5451-53220 | MTI DISTRIBUTING INC | SPINDLE | 01/29/2026 | 0 | 7.92 |
| | | Vendor Subtotal: | | | 207.92 |
| 5451-25-5451-53220 | VAN WALL EQUIPMENT INC. | Filter | 01/28/2026 | 0 | 58.75 |

| | | | | | |
|--------------------|-------------------------------|---------------------------|-------------------------|---|-----------------|
| | | | Vendor Subtotal: | | 58.75 |
| 5451-25-5451-53320 | WENDLING QUARRIES INC | BUNKER SAND | 01/28/2026 | 0 | 466.50 00031400 |
| 5451-25-5451-53320 | WENDLING QUARRIES INC | BUNKER SAND | 01/28/2026 | 0 | 107.66 |
| | | | Vendor Subtotal: | | 574.16 |
| 5451-25-5451-62210 | PHELPS THE UNIFORM SPECIALIST | Laundry - Golf | 01/29/2026 | 0 | 33.66 |
| | | | Vendor Subtotal: | | 33.66 |
| 5451-25-5451-62450 | A TECH/FREEMAN ALARM | Security 2/1/26 - 4/30/26 | 02/01/2026 | 0 | 114.00 |
| | | | Vendor Subtotal: | | 114.00 |
| 5451-25-5451-63300 | S.J. SMITH CO. | CO2 TANKS FOR CLUBHOUSE | 01/28/2026 | 0 | 248.33 00032616 |
| 5451-25-5451-63300 | S.J. SMITH CO. | DELIVERY | 01/28/2026 | 0 | 28.00 00032616 |
| | | | Vendor Subtotal: | | 276.33 |
| 5451-25-5451-64200 | IOWA TURFGRASS OFFICE | Conference - B Parcher | 01/28/2026 | 0 | 285.00 |
| 5451-25-5451-64200 | IOWA TURFGRASS OFFICE | Conference - S Meerdink | 01/28/2026 | 0 | 285.00 |
| | | | Vendor Subtotal: | | 570.00 |
| 5451-25-5451-65320 | EASTERN IOWA LIGHT & POWER C | December Power - Golf | 01/28/2026 | 0 | 584.97 |
| 5451-25-5451-65320 | EASTERN IOWA LIGHT & POWER C | December Power - Golf | 01/28/2026 | 0 | 192.56 |
| | | | Vendor Subtotal: | | 777.53 |
| 5451-25-5452-52851 | 7G DISTRIBUTING LLC | Credit on Account | 01/29/2026 | 0 | -30.00 |
| 5451-25-5452-52851 | 7G DISTRIBUTING LLC | Beer for Resale | 01/29/2026 | 0 | 148.10 |
| | | | Vendor Subtotal: | | 118.10 |
| | | | Subtotal for FUND: 5451 | | 3,034.43 |

| | | | | | |
|--------------------|-----------------------------|----------------------------|------------|---|-------------------|
| 5660-50-5661-51100 | AMAZON.COM | Sticky Pads/Paper Clips | 01/29/2026 | 0 | 34.71 |
| 5660-50-5661-51100 | AMAZON.COM | Ballpoint Pens | 01/29/2026 | 0 | 32.58 |
| | | Vendor Subtotal: | | | 67.29 |
| 5660-50-5662-52220 | HAWKINS, INC | Aqua Hawk | 01/29/2026 | 0 | 7,543.52 00032569 |
| 5660-50-5662-52220 | HAWKINS, INC | Aqua Hawk | 01/29/2026 | 0 | 552.01 |
| 5660-50-5662-52220 | HAWKINS, INC | Credit | 01/29/2026 | 0 | -572.01 |
| 5660-50-5662-52220 | HAWKINS, INC | Aqua Hawk | 01/28/2026 | 0 | 7,523.52 00032740 |
| | | Vendor Subtotal: | | | 15,047.04 |
| 5660-50-5662-52400 | MENARDS (MUSC) | Cleaning Supplies | 01/29/2026 | 0 | 34.44 00032702 |
| | | Vendor Subtotal: | | | 34.44 |
| 5660-50-5662-52740 | ARNOLD MOTOR SUPPLY | Oil | 01/28/2026 | 0 | 18.64 |
| | | Vendor Subtotal: | | | 18.64 |
| 5660-50-5662-52890 | SIGN WORKS OF MUSCATINE LLC | Hauler Decals | 01/29/2026 | 0 | 89.45 |
| | | Vendor Subtotal: | | | 89.45 |
| 5660-50-5662-53210 | ARNOLD MOTOR SUPPLY | Return | 01/29/2026 | 0 | -8.82 |
| 5660-50-5662-53210 | ARNOLD MOTOR SUPPLY | Filter | 01/29/2026 | 0 | 8.80 |
| | | Vendor Subtotal: | | | -0.02 |
| 5660-50-5662-53210 | GRAINGER DEPT 802675066 | Air Filters | 01/29/2026 | 0 | 157.92 00032731 |
| | | Vendor Subtotal: | | | 157.92 |
| 5660-50-5662-53210 | MENARDS (MUSC) | Gloves, Filters, Squeeeges | 01/29/2026 | 0 | 353.97 00032765 |
| | | Vendor Subtotal: | | | 353.97 |
| 5660-50-5662-53210 | AMAZON.COM | Filters | 01/29/2026 | 0 | 91.16 |
| 5660-50-5662-53210 | AMAZON.COM | Pump Parts | 01/29/2026 | 0 | 19.38 |

| | | | | | |
|--------------------|-------------------------------|---------------------------------------|------------|---|--------------------|
| 5660-50-5662-53210 | AMAZON.COM | Splitter Cable | 01/29/2026 | 0 | 16.87 |
| 5660-50-5662-53210 | AMAZON.COM | Plug | 01/29/2026 | 0 | 8.54 |
| 5660-50-5662-53210 | AMAZON.COM | Backup Alarm | 01/28/2026 | 0 | 14.24 |
| | | Vendor Subtotal: | | | 150.19 |
| 5660-50-5662-53220 | ARNOLD MOTOR SUPPLY | Switch | 01/29/2026 | 0 | 21.09 |
| | | Vendor Subtotal: | | | 21.09 |
| 5660-50-5662-53220 | MENARDS (MUSC) | Misc. Supplies | 01/29/2026 | 0 | 50.96 00032702 |
| | | Vendor Subtotal: | | | 50.96 |
| 5660-50-5662-53220 | VAN METER INDUSTRIAL INC | Fuses | 01/29/2026 | 0 | 39.71 |
| | | Vendor Subtotal: | | | 39.71 |
| 5660-50-5662-53220 | AMAZON.COM | Storage Tube/Welding Rod Holder Stick | 01/29/2026 | 0 | 93.64 |
| 5660-50-5662-53220 | AMAZON.COM | LED Light | 01/29/2026 | 0 | 35.14 |
| 5660-50-5662-53220 | AMAZON.COM | AM876265 John Deere Gator Fuel Pump | 01/29/2026 | 0 | 143.54 00032721 |
| | | Vendor Subtotal: | | | 272.32 |
| 5660-50-5662-61340 | INSOURCE SOLUTIONS GROUP | Annual Software Maintenance Renewal | 01/29/2026 | 0 | 20,622.44 00032691 |
| | | Vendor Subtotal: | | | 20,622.44 |
| 5660-50-5662-62210 | PHELPS THE UNIFORM SPECIALIST | Laundry - WRRF | 01/29/2026 | 0 | 289.01 |
| | | Vendor Subtotal: | | | 289.01 |
| 5660-50-5662-62240 | SCOTT COUNTY WASTE COMMISS | Waste Disposal | 01/29/2026 | 0 | 524.85 00032769 |
| | | Vendor Subtotal: | | | 524.85 |
| 5660-50-5662-65210 | MUSCATINE POWER & WATER | December Phones - WRRF Plant | 01/29/2026 | 0 | 20.99 |

| | | | | | | |
|--------------------|----------------------------|--|------------------|---|-----------|----------|
| | | | Vendor Subtotal: | | 20.99 | |
| 5660-50-5662-65275 | MUSCATINE POWER & WATER | December Internet - WRRF Plant | 01/29/2026 | 0 | 62.97 | |
| | | | Vendor Subtotal: | | 62.97 | |
| 5660-50-5662-65320 | MUSCATINE POWER & WATER | December Electric - W Bank | 01/29/2026 | 0 | 21,711.40 | |
| 5660-50-5662-65320 | MUSCATINE POWER & WATER | December Electric - E Bank | 01/29/2026 | 0 | 5,437.53 | |
| | | | Vendor Subtotal: | | 27,148.93 | |
| 5660-50-5662-65410 | MUSCATINE POWER & WATER | December Water - WRRF Plant | 01/29/2026 | 0 | 214.55 | |
| | | | Vendor Subtotal: | | 214.55 | |
| 5660-50-5662-67130 | ESCO AUTOMATION | Scada Repair | 01/29/2026 | 0 | 840.00 | 00032775 |
| | | | Vendor Subtotal: | | 840.00 | |
| 5660-50-5662-67130 | CRAWFORD COMPANY INC | Install Outside Airduct and Filters for M | 01/29/2026 | 0 | 12,930.00 | 00032741 |
| | | | Vendor Subtotal: | | 12,930.00 | |
| 5660-50-5662-67320 | DAVENPORT ELECTRIC CONTRAC | Labor/Materials to Install Wifi Hotspots i | 01/28/2026 | 0 | 889.34 | 00032562 |
| | | | Vendor Subtotal: | | 889.34 | |
| 5660-50-5663-52830 | GRAINGER DEPT 802675066 | Chisel Sets | 01/29/2026 | 0 | 66.09 | |
| | | | Vendor Subtotal: | | 66.09 | |
| 5660-50-5663-52830 | AMAZON.COM | Impact Wrench for Lift Station Truck | 01/29/2026 | 0 | 228.95 | 00032699 |
| | | | Vendor Subtotal: | | 228.95 | |
| 5660-50-5663-53130 | MENARDS (MUSC) | Union/Check Valve | 01/29/2026 | 0 | 37.36 | |
| 5660-50-5663-53130 | MENARDS (MUSC) | Ball Valve | 01/28/2026 | 0 | 60.44 | |

| | | | | | |
|--------------------|-------------------------|-----------------------------------|------------|---|-------------------|
| 5660-50-5663-53130 | MENARDS (MUSC) | Tubing/Elbow | 01/28/2026 | 0 | 12.99 |
| | | Vendor Subtotal: | | | 110.79 |
| 5660-50-5663-53210 | GRAINGER DEPT 802675066 | Welding Rod | 01/29/2026 | 0 | 4.75 |
| | | Vendor Subtotal: | | | 4.75 |
| 5660-50-5663-53220 | AMAZON.COM | SCH80 SS 2"x72" 304 Pipe | 01/29/2026 | 0 | 280.71 00032712 |
| 5660-50-5663-53220 | AMAZON.COM | Hose Clamp | 01/28/2026 | 0 | 14.69 |
| | | Vendor Subtotal: | | | 295.40 |
| 5660-50-5663-63300 | UNITED RENTALS (MUSC) | 6" Hydraulic Pump Rental/Repair | 01/29/2026 | 0 | 1,000.00 00032781 |
| | | Vendor Subtotal: | | | 1,000.00 |
| 5660-50-5663-65275 | MUSCATINE POWER & WATER | January Internet - Bond | 01/29/2026 | 0 | 21.79 |
| 5660-50-5663-65275 | MUSCATINE POWER & WATER | January Internet - Canon | 01/29/2026 | 0 | 21.79 |
| 5660-50-5663-65275 | MUSCATINE POWER & WATER | January Internet - Papoose | 01/29/2026 | 0 | 21.78 |
| 5660-50-5663-65275 | MUSCATINE POWER & WATER | January Internet - Schley | 01/29/2026 | 0 | 21.78 |
| 5660-50-5663-65275 | MUSCATINE POWER & WATER | January Internet - Spinning Wheel | 01/29/2026 | 0 | 21.78 |
| 5660-50-5663-65275 | MUSCATINE POWER & WATER | January Internet - Hershey | 01/29/2026 | 0 | 21.78 |
| 5660-50-5663-65275 | MUSCATINE POWER & WATER | December Internet - Tipton | 01/29/2026 | 0 | 42.50 |
| 5660-50-5663-65275 | MUSCATINE POWER & WATER | December Internet - Love's | 01/29/2026 | 0 | 10.63 |
| 5660-50-5663-65275 | MUSCATINE POWER & WATER | December Internet - 57th | 01/29/2026 | 0 | 10.63 |
| 5660-50-5663-65275 | MUSCATINE POWER & WATER | December Internet - Progress | 01/29/2026 | 0 | 42.50 |
| 5660-50-5663-65275 | MUSCATINE POWER & WATER | December Internet - Sampson | 01/29/2026 | 0 | 10.63 |
| 5660-50-5663-65275 | MUSCATINE POWER & WATER | December Internet - Isett | 01/29/2026 | 0 | 10.63 |
| 5660-50-5663-65275 | MUSCATINE POWER & WATER | December Internet - Mad Creek | 01/29/2026 | 0 | 42.50 |
| 5660-50-5663-65275 | MUSCATINE POWER & WATER | December Internet - Slough | 01/29/2026 | 0 | 10.63 |
| 5660-50-5663-65275 | MUSCATINE POWER & WATER | December Internet - Miles | 01/28/2026 | 0 | 29.22 |
| | | Vendor Subtotal: | | | 340.57 |
| 5660-50-5663-65310 | ALLIANT ENERGY | December Gas - Arbor Commons | 01/29/2026 | 0 | 42.20 |
| 5660-50-5663-65310 | ALLIANT ENERGY | December Gas - Love's | 01/28/2026 | 0 | 936.92 |
| | | Vendor Subtotal: | | | 979.12 |

| | | | | | |
|--------------------|-------------------------|---|------------|---|-------------------|
| 5660-50-5663-65320 | MUSCATINE POWER & WATER | December Electric - Love's | 01/29/2026 | 0 | 519.02 |
| 5660-50-5663-65320 | MUSCATINE POWER & WATER | December Electric - Progress | 01/29/2026 | 0 | 868.84 |
| 5660-50-5663-65320 | MUSCATINE POWER & WATER | December Electric - Tipton | 01/29/2026 | 0 | 432.25 |
| 5660-50-5663-65320 | MUSCATINE POWER & WATER | December Electric - 57th | 01/29/2026 | 0 | 385.96 |
| 5660-50-5663-65320 | MUSCATINE POWER & WATER | December Electric - Papoose | 01/29/2026 | 0 | 2,747.63 |
| 5660-50-5663-65320 | MUSCATINE POWER & WATER | December Electric - Isett | 01/29/2026 | 0 | 2,241.48 |
| 5660-50-5663-65320 | MUSCATINE POWER & WATER | December Electric - Sampson | 01/29/2026 | 0 | 1,485.91 |
| 5660-50-5663-65320 | MUSCATINE POWER & WATER | December Electric - Sunset | 01/29/2026 | 0 | 76.25 |
| 5660-50-5663-65320 | MUSCATINE POWER & WATER | December Electric - Papoose | 01/29/2026 | 0 | 633.86 |
| 5660-50-5663-65320 | MUSCATINE POWER & WATER | December Electric - Mad Creek | 01/29/2026 | 0 | 2,034.43 |
| 5660-50-5663-65320 | MUSCATINE POWER & WATER | December Electric - Stormwater | 01/29/2026 | 0 | 149.88 |
| 5660-50-5663-65320 | MUSCATINE POWER & WATER | December Electric - Slough | 01/29/2026 | 0 | 90.55 |
| 5660-50-5663-65320 | MUSCATINE POWER & WATER | December Electric - Magnolia | 01/29/2026 | 0 | 28.78 |
| 5660-50-5663-65320 | MUSCATINE POWER & WATER | December Electric - Schley | 01/28/2026 | 0 | 146.90 |
| 5660-50-5663-65320 | MUSCATINE POWER & WATER | December Electric - Miles | 01/28/2026 | 0 | 756.31 |
| 5660-50-5663-65320 | MUSCATINE POWER & WATER | December Electric - Hershey | 01/28/2026 | 0 | 243.18 |
| 5660-50-5663-65320 | MUSCATINE POWER & WATER | December Electric - Hershey | 01/28/2026 | 0 | 26.58 |
| 5660-50-5663-65320 | MUSCATINE POWER & WATER | December Electric - Bond | 01/28/2026 | 0 | 199.04 |
| Vendor Subtotal: | | | | | 13,066.85 |
| 5660-50-5663-65410 | MUSCATINE POWER & WATER | December Water - Tipton | 01/29/2026 | 0 | 22.13 |
| 5660-50-5663-65410 | MUSCATINE POWER & WATER | December Water - Love's | 01/29/2026 | 0 | 35.39 |
| 5660-50-5663-65410 | MUSCATINE POWER & WATER | December Water - 57th | 01/29/2026 | 0 | 22.13 |
| 5660-50-5663-65410 | MUSCATINE POWER & WATER | December Water - Progress | 01/29/2026 | 0 | 26.54 |
| 5660-50-5663-65410 | MUSCATINE POWER & WATER | December Water - Sampson | 01/29/2026 | 0 | 22.13 |
| 5660-50-5663-65410 | MUSCATINE POWER & WATER | December Water - Isett | 01/29/2026 | 0 | 443.97 |
| 5660-50-5663-65410 | MUSCATINE POWER & WATER | December Water - Mad Creek | 01/29/2026 | 0 | 213.09 |
| 5660-50-5663-65410 | MUSCATINE POWER & WATER | December Water - Bond | 01/28/2026 | 0 | 386.80 |
| 5660-50-5663-65410 | MUSCATINE POWER & WATER | December Water - Schley | 01/28/2026 | 0 | 22.13 |
| 5660-50-5663-65410 | MUSCATINE POWER & WATER | December Water - Miles | 01/28/2026 | 0 | 22.13 |
| 5660-50-5663-65410 | MUSCATINE POWER & WATER | December Water - Hershey | 01/28/2026 | 0 | 25.83 |
| Vendor Subtotal: | | | | | 1,242.27 |
| 5660-50-5663-67130 | BOB'S CRANE SERVICE L C | Crane Fee for Installing Slough #2 Pump | 01/28/2026 | 0 | 480.00 00032710 |
| 5660-50-5663-67130 | BOB'S CRANE SERVICE L C | Crane Fee for Installing Slough #2 Pump | 01/28/2026 | 0 | 440.00 |
| Vendor Subtotal: | | | | | 920.00 |
| 5660-50-5663-73900 | MARK A DIERCKS | Push Bar Assembly for Miles Control Ro | 01/28/2026 | 0 | 3,960.00 00032794 |

| | | | | | |
|--------------------|-------------------------------|---------------------------------------|------------------|---|-------------------|
| | | | Vendor Subtotal: | | 3,960.00 |
| 5660-50-5665-52210 | VELP SCIENTIFIC INC | Lab Supplies | 01/29/2026 | 0 | 244.90 00032746 |
| | | | Vendor Subtotal: | | 244.90 |
| 5660-50-5665-52210 | COLE-PARMER INSTRUMENT CO | Return | 01/29/2026 | 0 | -496.50 |
| 5660-50-5665-52210 | COLE-PARMER INSTRUMENT CO | Digital Strirrer | 01/29/2026 | 0 | 496.50 |
| 5660-50-5665-52210 | COLE-PARMER INSTRUMENT CO | Environmental Express Vacuu Manifold, | 01/29/2026 | 0 | 522.11 00032768 |
| | | | Vendor Subtotal: | | 522.11 |
| 5660-50-5665-52210 | GFS CHEMICALS INC. | Lab Supplies | 01/29/2026 | 0 | 1,499.18 00032688 |
| | | | Vendor Subtotal: | | 1,499.18 |
| 5660-50-5665-52210 | MENARDS (MUSC) | Lab Water | 01/29/2026 | 0 | 16.44 00032702 |
| | | | Vendor Subtotal: | | 16.44 |
| 5660-50-5665-52210 | MIDLAND SCIENTIFIC INC | Ammonium | 01/29/2026 | 0 | 84.78 |
| 5660-50-5665-52210 | MIDLAND SCIENTIFIC INC | Lab Supplies | 01/29/2026 | 0 | 696.67 00032750 |
| 5660-50-5665-52210 | MIDLAND SCIENTIFIC INC | Glass Fiber Filter/Transfer Pipet | 01/28/2026 | 0 | 899.13 |
| 5660-50-5665-52210 | MIDLAND SCIENTIFIC INC | Aluminum Weigh Dishes | 01/28/2026 | 0 | 370.50 00032777 |
| 5660-50-5665-52210 | MIDLAND SCIENTIFIC INC | Aluminum Weigh Dishes | 01/28/2026 | 0 | 0.75 |
| | | | Vendor Subtotal: | | 2,051.83 |
| 5660-50-5665-62510 | MICROBAC LABORATORIES INC | Lab Testing | 01/29/2026 | 0 | 4,066.75 00032737 |
| | | | Vendor Subtotal: | | 4,066.75 |
| 5660-50-5665-63500 | PHELPS THE UNIFORM SPECIALIST | Laundry - WRRF | 01/29/2026 | 0 | 29.82 |
| | | | Vendor Subtotal: | | 29.82 |
| 5660-50-5668-52400 | GRAINGER DEPT 802675066 | Floor Squeegee | 01/29/2026 | 0 | 65.75 |

| | | | | | |
|--------------------|----------------------------|--|-------------------------|---|-------------------|
| | | | Vendor Subtotal: | | 65.75 |
| 5660-50-5668-53210 | MENARDS (MUSC) | Gloves | 01/29/2026 | 0 | 19.88 00032765 |
| | | | Vendor Subtotal: | | 19.88 |
| 5660-50-5668-67130 | DAVENPORT ELECTRIC CONTRAC | Install Weatherproof GFCI Switch and G | 01/29/2026 | 0 | 1,041.53 00032796 |
| | | | Vendor Subtotal: | | 1,041.53 |
| 5660-50-5668-67130 | CRAWFORD COMPANY INC | Labor & Material to Add a Floor Drain ir | 01/29/2026 | 0 | 642.00 00032795 |
| | | | Vendor Subtotal: | | 642.00 |
| | | | Subtotal for FUND: 5660 | | 112,261.06 |
| 5664-40-5664-52300 | NORTHERN SAFETY CO INC | Bomber Jacket | 01/28/2026 | 0 | 70.11 |
| | | | Vendor Subtotal: | | 70.11 |
| 5664-40-5664-52300 | AMAZON.COM | Winter Parka | 01/28/2026 | 0 | 63.38 |
| | | | Vendor Subtotal: | | 63.38 |
| 5664-40-5664-52830 | MENARDS (MUSC) | Hose | 01/28/2026 | 0 | 46.73 |
| | | | Vendor Subtotal: | | 46.73 |
| 5664-40-5664-65275 | MIDWEST WIRELESS LLC | Radio | 01/29/2026 | 0 | 75.60 |
| | | | Vendor Subtotal: | | 75.60 |
| 5664-40-5664-73100 | BRODERS EXCAVATING | Emergency Repair - Art Center Sewer M | 01/29/2026 | 0 | 4,601.00 00032674 |
| 5664-40-5664-73100 | BRODERS EXCAVATING | Emergency Repair - Art Center Sewer M | 01/29/2026 | 0 | 4,028.00 |
| 5664-40-5664-73100 | BRODERS EXCAVATING | Emergency Sewer Main Repair @ Orang | 01/29/2026 | 0 | 4,140.00 00032753 |
| | | | Vendor Subtotal: | | 12,769.00 |

| | | | | | |
|--------------------|-------------------------------|--|------------|---|-------------------|
| 5664-50-5667-61420 | BRADLEY W ROETH | Engineering Fees for Slough Lift Station | 01/29/2026 | 0 | 1,162.50 00032780 |
| | | Vendor Subtotal: | | | 1,162.50 |
| 5664-50-5667-62530 | PS3 Enterprises Inc. | Temp Sanitation | 01/28/2026 | 0 | 180.00 |
| | | Vendor Subtotal: | | | 180.00 |
| | | Subtotal for FUND: 5664 | | | 14,367.32 |
| 5711-10-5711-61650 | CARVER AERO INC | February 2026 | 02/01/2026 | 0 | 3,875.00 |
| | | Vendor Subtotal: | | | 3,875.00 |
| 5711-10-5711-67320 | MUSCATINE LAWN & POWER | Mower Blades for Airport Mower | 01/29/2026 | 0 | 136.32 00032727 |
| | | Vendor Subtotal: | | | 136.32 |
| | | Subtotal for FUND: 5711 | | | 4,011.32 |
| 5811-00-0000-23150 | ILLINOIS DEPARTMENT OF REVEN | PR Batch 00003.01.2026 State Income T | 01/30/2026 | 0 | 15.77 |
| 5811-00-0000-23150 | ILLINOIS DEPARTMENT OF REVEN | PR Batch 00001.01.2026 State Income T | 01/02/2026 | 0 | 18.67 |
| 5811-00-0000-23150 | ILLINOIS DEPARTMENT OF REVEN | PR Batch 00002.01.2026 State Income T | 01/16/2026 | 0 | 2.72 |
| | | Vendor Subtotal: | | | 37.16 |
| 5811-20-5811-35150 | IOWA MEDICAID ENTERPRISE (IME | State Share of GEMT | 01/28/2026 | 0 | 27,173.15 |
| | | Vendor Subtotal: | | | 27,173.15 |
| 5811-20-5811-35160 | COTIVITI | Reimb Ambulance C Tisor DOS 9/26/24 | 01/28/2026 | 0 | 236.24 |
| | | Vendor Subtotal: | | | 236.24 |
| 5811-20-5811-52840 | LIFE-ASSIST | #2406 Masimo M L NCS Rainbow Sp02 | 01/29/2026 | 0 | 183.57 00032778 |
| | | Vendor Subtotal: | | | 183.57 |

| | | | | | | |
|--------------------|------------------------------|--|------------|---|----------|----------|
| 5811-20-5811-52840 | BOUND TREE MEDICAL LLC | Assure Prism Multi Blood Glucose Test | 01/28/2026 | 0 | 59.40 | 00032817 |
| 5811-20-5811-52840 | BOUND TREE MEDICAL LLC | Curaplex Cuffed Endotracheal Tube with | 01/28/2026 | 0 | 15.70 | 00032817 |
| 5811-20-5811-52840 | BOUND TREE MEDICAL LLC | 3M Transpore Surgical Tape Clear 1.5yd | 01/28/2026 | 0 | 49.49 | 00032817 |
| 5811-20-5811-52840 | BOUND TREE MEDICAL LLC | Co-Lastic Cohesive Elastic Bandage Tan | 01/28/2026 | 0 | 60.24 | 00032817 |
| 5811-20-5811-52840 | BOUND TREE MEDICAL LLC | 3M Transpore Surgical Tape Clear 1.5yd | 01/28/2026 | 0 | 261.80 | 00032817 |
| 5811-20-5811-52840 | BOUND TREE MEDICAL LLC | Primary IV Administration Set 15 Drop | 01/28/2026 | 0 | 169.50 | 00032817 |
| 5811-20-5811-52840 | BOUND TREE MEDICAL LLC | Defib Pads | 01/29/2026 | 0 | 83.58 | |
| 5811-20-5811-52840 | BOUND TREE MEDICAL LLC | Replacement Latch | 01/29/2026 | 0 | 29.88 | |
| 5811-20-5811-52840 | BOUND TREE MEDICAL LLC | Decompression Needle | 01/29/2026 | 0 | 98.01 | |
| | | Vendor Subtotal: | | | 827.60 | |
| 5811-20-5811-52840 | UNITYPOINT HEALTH | Ambulance Restock | 01/29/2026 | 0 | 396.21 | |
| | | Vendor Subtotal: | | | 396.21 | |
| 5811-20-5811-52890 | AMAZON.COM | DMI Adapter | 01/28/2026 | 0 | 12.14 | |
| | | Vendor Subtotal: | | | 12.14 | |
| 5811-20-5811-53220 | AMAZON.COM | Air Compressor Switch | 01/28/2026 | 0 | 33.99 | |
| 5811-20-5811-53220 | AMAZON.COM | Sierra Wireless AireLink Antenna - Amb | 01/29/2026 | 0 | 292.95 | 00032512 |
| | | Vendor Subtotal: | | | 326.94 | |
| 5811-20-5811-62220 | STERICYCLE INC | Medical Waste Hauling | 01/28/2026 | 0 | 259.49 | |
| | | Vendor Subtotal: | | | 259.49 | |
| 5811-20-5811-62290 | STERICYCLE INC | Shredding | 01/28/2026 | 0 | 49.87 | |
| | | Vendor Subtotal: | | | 49.87 | |
| 5811-20-5811-64200 | EASTERN IA COMMUNITY COLLEGE | ACLS - Renewal | 01/29/2026 | 0 | 90.00 | |
| | | Vendor Subtotal: | | | 90.00 | |
| 5811-20-5811-64600 | EASTERN IA COMMUNITY COLLEGE | Paramedic II Hickenbottom/Martin | 01/29/2026 | 0 | 7,000.00 | |

| | | | | | |
|--------------------|------------------------------|--|-------------------------|---|--------------------|
| | | | Vendor Subtotal: | | 7,000.00 |
| 5811-20-5811-65240 | MUSCATINE POWER & WATER | December Internet - S Fire | 01/29/2026 | 0 | 255.00 |
| | | | Vendor Subtotal: | | 255.00 |
| 5811-20-5811-67130 | COURTESY FORD | Shop Supplies for 351 | 01/28/2026 | 0 | 35.71 00032816 |
| 5811-20-5811-67130 | COURTESY FORD | Spark Plugs for 351 | 01/28/2026 | 0 | 74.80 00032816 |
| 5811-20-5811-67130 | COURTESY FORD | Ignition Coil Assy for 351 | 01/28/2026 | 0 | 217.47 00032816 |
| 5811-20-5811-67130 | COURTESY FORD | Diagnose/Replace Spark Plugs/3 Coils f | 01/28/2026 | 0 | 1,075.02 00032816 |
| | | | Vendor Subtotal: | | 1,403.00 |
| 5811-20-5811-67130 | STOLLS AUTOBODY LLC | Ambulance #352 Body Repair | 01/29/2026 | 0 | 1,338.00 00032287 |
| | | | Vendor Subtotal: | | 1,338.00 |
| 5811-20-5811-67310 | ADVANCED BUSINESS SYSTEMS IT | Copier | 01/29/2026 | 0 | 47.00 |
| | | | Vendor Subtotal: | | 47.00 |
| 5811-20-5811-67310 | LUCAS COMMUNICATION INC | VM to Email Set Up | 01/28/2026 | 0 | 190.00 |
| | | | Vendor Subtotal: | | 190.00 |
| 5811-20-5811-67310 | ADVANCED BUSINESS SYSTEMS IT | | 01/29/2026 | 0 | 160.85 |
| | | | Vendor Subtotal: | | 160.85 |
| | | | Subtotal for FUND: 5811 | | 39,986.22 |
| 7625-40-7625-52400 | ARNOLD MOTOR SUPPLY | Gloves | 01/28/2026 | 0 | 45.98 |
| | | | Vendor Subtotal: | | 45.98 |
| 7625-40-7625-52720 | HARMS OIL COMPANY | Gas for Tank #2 | 01/28/2026 | 0 | 16,105.59 00032813 |

| | | | | | | |
|--------------------|----------------------------|--------------------------------|------------|---|------------------|-----------|
| | | | | | Vendor Subtotal: | 16,105.59 |
| 7625-40-7625-52740 | RAINBO OIL CO-JET BULK OIL | 5w30 DEXOS Gas Oil | 01/28/2026 | 0 | 748.50 | 00032679 |
| 7625-40-7625-52740 | RAINBO OIL CO-JET BULK OIL | 55 Gallon Drum of Premixed WWS | 01/28/2026 | 0 | 90.75 | 00032679 |
| 7625-40-7625-52740 | RAINBO OIL CO-JET BULK OIL | 40 Tubes of Mystic Grease | 01/28/2026 | 0 | 182.80 | 00032679 |
| 7625-40-7625-52740 | RAINBO OIL CO-JET BULK OIL | DEXCO Gas Oil | 01/28/2026 | 0 | 69.86 | |
| | | | | | Vendor Subtotal: | 1,091.91 |
| 7625-40-7625-52740 | RILCO INC | 55 Gallon hyd TS | 01/29/2026 | 0 | 375.00 | 00032735 |
| 7625-40-7625-52740 | RILCO INC | 15w40 Diesel Oil | 01/28/2026 | 0 | 968.75 | 00032680 |
| 7625-40-7625-52740 | RILCO INC | MV ATF | 01/28/2026 | 0 | 1,455.00 | 00032680 |
| 7625-40-7625-52740 | RILCO INC | Premixed AF Universal | 01/28/2026 | 0 | 220.00 | 00032680 |
| | | | | | Vendor Subtotal: | 3,018.75 |
| 7625-40-7625-53210 | ARNOLD MOTOR SUPPLY | Wiper Blades | 01/29/2026 | 0 | 25.78 | |
| 7625-40-7625-53210 | ARNOLD MOTOR SUPPLY | Filters | 01/29/2026 | 0 | 27.51 | |
| 7625-40-7625-53210 | ARNOLD MOTOR SUPPLY | Brake Cleaner for Stock | 01/29/2026 | 0 | 150.84 | 00032812 |
| 7625-40-7625-53210 | ARNOLD MOTOR SUPPLY | Fuses | 01/29/2026 | 0 | 10.58 | |
| 7625-40-7625-53210 | ARNOLD MOTOR SUPPLY | Wire | 01/29/2026 | 0 | 27.99 | |
| 7625-40-7625-53210 | ARNOLD MOTOR SUPPLY | Switches for Stock | 01/29/2026 | 0 | 48.49 | |
| 7625-40-7625-53210 | ARNOLD MOTOR SUPPLY | Anti-Gel | 01/28/2026 | 0 | 91.14 | |
| 7625-40-7625-53210 | ARNOLD MOTOR SUPPLY | Silicone Brake Lubricant | 01/28/2026 | 0 | 98.97 | |
| 7625-40-7625-53210 | ARNOLD MOTOR SUPPLY | Filters | 01/28/2026 | 0 | 44.00 | |
| 7625-40-7625-53210 | ARNOLD MOTOR SUPPLY | Tee Wrap | 01/28/2026 | 0 | 43.98 | |
| 7625-40-7625-53210 | ARNOLD MOTOR SUPPLY | Filter | 01/28/2026 | 0 | 34.94 | |
| 7625-40-7625-53210 | ARNOLD MOTOR SUPPLY | Toggle Pan | 01/28/2026 | 0 | 5.72 | |
| | | | | | Vendor Subtotal: | 609.94 |
| 7625-40-7625-53210 | AMAZON.COM | Wiper Blades | 01/29/2026 | 0 | 22.78 | |
| 7625-40-7625-53210 | AMAZON.COM | Wiper Blades | 01/28/2026 | 0 | 109.23 | 00032696 |
| | | | | | Vendor Subtotal: | 132.01 |
| 7625-40-7625-53220 | ARNOLD MOTOR SUPPLY | Wiper Blades | 01/29/2026 | 0 | 25.78 | |
| 7625-40-7625-53220 | ARNOLD MOTOR SUPPLY | Heater Hose/Hose Connector | 01/29/2026 | 0 | 81.97 | |
| 7625-40-7625-53220 | ARNOLD MOTOR SUPPLY | Bulb | 01/29/2026 | 0 | 2.50 | |
| 7625-40-7625-53220 | ARNOLD MOTOR SUPPLY | Tubing | 01/29/2026 | 0 | 11.96 | |

| | | | | | |
|--------------------|-----------------------------|---------------------------------------|------------|---|-----------------|
| 7625-40-7625-53220 | ARNOLD MOTOR SUPPLY | Filter | 01/29/2026 | 0 | 13.19 |
| 7625-40-7625-53220 | ARNOLD MOTOR SUPPLY | Nylon Air Line | 01/29/2026 | 0 | 11.70 |
| 7625-40-7625-53220 | ARNOLD MOTOR SUPPLY | Oxygen for Torch | 01/29/2026 | 0 | 70.95 |
| 7625-40-7625-53220 | ARNOLD MOTOR SUPPLY | Shift Tube Lever Plunger Shaft | 01/28/2026 | 0 | 30.80 |
| 7625-40-7625-53220 | ARNOLD MOTOR SUPPLY | Transmission Shift Interlock Solenoid | 01/28/2026 | 0 | 145.78 |
| | | Vendor Subtotal: | | | 394.63 |
| 7625-40-7625-53220 | ELLIOTT EQUIPMENT COMPANY | Pressure Filter | 01/28/2026 | 0 | 32.98 |
| | | Vendor Subtotal: | | | 32.98 |
| 7625-40-7625-53220 | NORTH CENTRAL INTERNATIONAL | Coolant Hoses for 262 | 01/28/2026 | 0 | 101.13 00032757 |
| | | Vendor Subtotal: | | | 101.13 |
| 7625-40-7625-53220 | MENARDS (MUSC) | Fasteners | 01/29/2026 | 0 | 28.78 |
| | | Vendor Subtotal: | | | 28.78 |
| 7625-40-7625-53220 | REEVES BATTERY SALES | Batteries for 256 | 01/29/2026 | 0 | 360.00 00032779 |
| 7625-40-7625-53220 | REEVES BATTERY SALES | Battery for 648 | 01/29/2026 | 0 | 150.00 00032799 |
| 7625-40-7625-53220 | REEVES BATTERY SALES | Battery for 143 | 01/28/2026 | 0 | 130.00 00032823 |
| | | Vendor Subtotal: | | | 640.00 |
| 7625-40-7625-53220 | TRUCK COUNTRY OF IOWA | Fuel Tank Straps for 106 | 01/29/2026 | 0 | 709.56 00032766 |
| | | Vendor Subtotal: | | | 709.56 |
| 7625-40-7625-53220 | EMAG MUSCATINE FD LLC | Switch | 01/28/2026 | 0 | 53.34 |
| | | Vendor Subtotal: | | | 53.34 |
| 7625-40-7625-62530 | SAFETY-KLEEN, INC | Used Oil | 01/29/2026 | 0 | 125.53 |
| | | Vendor Subtotal: | | | 125.53 |
| 7625-40-7625-67130 | EMAG MUSCATINE CBG LLC | Steering #756 | 01/28/2026 | 0 | 166.95 |

| | | | | | | |
|--------------------|------------------------------|-------------------------------------|-------------------------|---|--|-----------------|
| | | | Vendor Subtotal: | | | 166.95 |
| 7625-40-7625-67140 | A-1 QUALITY TIRE & CAR CARE | Tire Repairs #260 | 01/29/2026 | 0 | | 42.00 |
| 7625-40-7625-67140 | A-1 QUALITY TIRE & CAR CARE | Tire Repairs #25 | 01/29/2026 | 0 | | 10.00 |
| 7625-40-7625-67140 | A-1 QUALITY TIRE & CAR CARE | Repairs #703 | 01/29/2026 | 0 | | 29.07 |
| 7625-40-7625-67140 | A-1 QUALITY TIRE & CAR CARE | 2 Tires for 256 Stock | 01/29/2026 | 0 | | 275.80 00032790 |
| 7625-40-7625-67140 | A-1 QUALITY TIRE & CAR CARE | Mount Tires #256 | 01/29/2026 | 0 | | 42.84 |
| 7625-40-7625-67140 | A-1 QUALITY TIRE & CAR CARE | Repairs for RC15 | 01/28/2026 | 0 | | 150.90 00032730 |
| 7625-40-7625-67140 | A-1 QUALITY TIRE & CAR CARE | Repairs for RC15 | 01/28/2026 | 0 | | 102.50 00032811 |
| 7625-40-7625-67140 | A-1 QUALITY TIRE & CAR CARE | Police Car Tires for Stock | 01/28/2026 | 0 | | 629.28 00032800 |
| 7625-40-7625-67140 | A-1 QUALITY TIRE & CAR CARE | Mount Tires #752 | 01/28/2026 | 0 | | 63.00 |
| | | | Vendor Subtotal: | | | 1,345.39 |
| | | | Subtotal for FUND: 7625 | | | 24,602.47 |
| 7921-00-7921-69900 | DAVENPORT PUBLIC LIBRARY | Reimb - Learn to Draw Hooky | 01/29/2026 | 0 | | 30.00 |
| | | | Vendor Subtotal: | | | 30.00 |
| 7921-00-7921-69900 | SCOTT COUNTY | Reimb - Never Pop a Dinosaur | 01/29/2026 | 0 | | 10.00 |
| | | | Vendor Subtotal: | | | 10.00 |
| | | | Subtotal for FUND: 7921 | | | 40.00 |
| 8142-10-8142-61420 | BOLTON & MENK INC | Mulberry Ave Sidewalk | 01/28/2026 | 0 | | 16,146.00 |
| | | | Vendor Subtotal: | | | 16,146.00 |
| 8142-10-8142-61660 | BI-STATE REGIONAL COMMISSION | Cost for CDBG-CNRG | 01/29/2026 | 0 | | 3,773.13 |
| | | | Vendor Subtotal: | | | 3,773.13 |
| | | | Subtotal for FUND: 8142 | | | 19,919.13 |
| 8146-10-8146-61660 | MARTIN GARDNER ARCHITECTUR | Muscatine Downtown Historic Revital | 01/28/2026 | 0 | | 3,215.89 |

| | | | | | |
|--------------------|------------------------------|-------------------------------|------------|-------------------------|--------------------|
| | | | | Vendor Subtotal: | 3,215.89 |
| | | | | Subtotal for FUND: 8146 | 3,215.89 |
| 8148-10-8148-61550 | GENESIS HEALTH SYSTEM-OCC HI | New Hire - M Dolan | 01/28/2026 | 0 | 40.00 |
| | | | | Vendor Subtotal: | 40.00 |
| 8148-10-8148-61660 | BI-STATE REGIONAL COMMISSION | Cost for Lead Program | 01/29/2026 | 0 | 1,447.52 |
| | | | | Vendor Subtotal: | 1,447.52 |
| | | | | Subtotal for FUND: 8148 | 1,487.52 |
| 8400-05-8400-74200 | EMAG MUSCATINE FD LLC | 2026 CHEVROLET SILVERADO 3500 | 01/28/2026 | 0 | 71,712.00 00031675 |
| 8400-05-8400-74200 | EMAG MUSCATINE FD LLC | 2026 CHEVROLET SILVERADO 3500 | 01/28/2026 | 0 | 260.00 |
| | | | | Vendor Subtotal: | 71,972.00 |
| | | | | Subtotal for FUND: 8400 | 71,972.00 |
| 8450-05-8450-74250 | AMAZON.COM | SMX2000RMLV2UNC APC Smart-UPS | 01/28/2026 | 0 | 1,681.93 00032722 |
| 8450-05-8450-74250 | AMAZON.COM | Adapter | 01/29/2026 | 0 | 9.98 |
| | | | | Vendor Subtotal: | 1,691.91 |
| | | | | Subtotal for FUND: 8450 | 1,691.91 |
| 9002-90-9020-41100 | CITY OF MUSCATINE HOUSING RE | Admin Full-Time Wages 1/16/25 | 01/28/2026 | 0 | 4,197.85 |
| 9002-90-9020-41100 | CITY OF MUSCATINE HOUSING RE | Admin Longevity 1/16/25 | 01/28/2026 | 0 | 5.20 |
| | | | | Vendor Subtotal: | 4,203.05 |
| 9002-90-9020-41701 | CITY OF MUSCATINE | FY 25/26 Accounting Fees | 01/29/2026 | 0 | 32,000.00 |
| | | | | Vendor Subtotal: | 32,000.00 |

| | | | | | |
|--------------------|--|---------------------------------|------------|---|----------|
| 9002-90-9020-41904 | CITY OF MUSCATINE HOUSING RE Phones | | 01/28/2026 | 0 | 4.50 |
| | | Vendor Subtotal: | | | 4.50 |
| 9002-90-9020-41904 | MUSCATINE POWER & WATER | December Phone - Clark House | 01/28/2026 | 0 | 87.03 |
| | | Vendor Subtotal: | | | 87.03 |
| 9002-90-9020-41908 | CITY OF MUSCATINE | IT Fees | 01/29/2026 | 0 | 2,200.00 |
| | | Vendor Subtotal: | | | 2,200.00 |
| 9002-90-9020-41914 | MUSCATINE POWER & WATER | December Internet - Clark House | 01/28/2026 | 0 | 82.97 |
| | | Vendor Subtotal: | | | 82.97 |
| 9002-90-9020-43100 | MUSCATINE POWER & WATER | December Water - Clark House | 01/28/2026 | 0 | 314.49 |
| | | Vendor Subtotal: | | | 314.49 |
| 9002-90-9020-43200 | MUSCATINE POWER & WATER | December Electric - Clark House | 01/28/2026 | 0 | 4,754.28 |
| | | Vendor Subtotal: | | | 4,754.28 |
| 9002-90-9020-43900 | MUSCATINE POWER & WATER | December Sewer - Clark House | 01/28/2026 | 0 | 913.09 |
| | | Vendor Subtotal: | | | 913.09 |
| 9002-90-9020-44100 | CITY OF MUSCATINE HOUSING RE Maint Full-Time Wages 1/16/25 | | 01/28/2026 | 0 | 3,060.60 |
| 9002-90-9020-44100 | CITY OF MUSCATINE HOUSING RE Maint Part-Time Wages 1/16/25 | | 01/28/2026 | 0 | 1,297.44 |
| 9002-90-9020-44100 | CITY OF MUSCATINE HOUSING RE Maint Longevity 1/16/25 | | 01/28/2026 | 0 | 14.30 |
| | | Vendor Subtotal: | | | 4,372.34 |
| 9002-90-9020-44201 | CITY OF MUSCATINE HOUSING RE July - Dec Cleaning Supplies | | 01/29/2026 | 0 | 186.80 |
| | | Vendor Subtotal: | | | 186.80 |

| | | | | | |
|--------------------|----------------------|--|------------|---|-----------------|
| 9002-90-9020-44204 | AMAZON.COM | Bulletin Board/Floating Shelf | 01/28/2026 | 0 | 97.94 |
| | | Vendor Subtotal: | | | 97.94 |
| 9002-90-9020-44205 | MENARDS (MUSC) | Light Bulbs | 01/28/2026 | 0 | 63.72 |
| 9002-90-9020-44205 | MENARDS (MUSC) | Ceiling Light | 01/28/2026 | 0 | 95.95 |
| 9002-90-9020-44205 | MENARDS (MUSC) | Fuses | 01/28/2026 | 0 | 76.90 |
| | | Vendor Subtotal: | | | 236.57 |
| 9002-90-9020-44205 | AMAZON.COM | Power Connectors | 01/28/2026 | 0 | 60.25 |
| | | Vendor Subtotal: | | | 60.25 |
| 9002-90-9020-44206 | MENARDS (MUSC) | Hook/Curtain Pins | 01/28/2026 | 0 | 20.59 |
| 9002-90-9020-44206 | MENARDS (MUSC) | Tubing | 01/28/2026 | 0 | 23.94 |
| | | Vendor Subtotal: | | | 44.53 |
| 9002-90-9020-44206 | PLUMB SUPPLY COMPANY | Drain Cleaner | 01/29/2026 | 0 | 42.49 |
| 9002-90-9020-44206 | PLUMB SUPPLY COMPANY | CH Lavatory Faucet Stock per Quote: De | 01/28/2026 | 0 | 500.07 00032213 |
| | | Vendor Subtotal: | | | 542.56 |
| 9002-90-9020-44206 | AMAZON.COM | Tub Stopper | 01/28/2026 | 0 | 28.41 |
| 9002-90-9020-44206 | AMAZON.COM | Stem Assembly | 01/28/2026 | 0 | 71.98 |
| | | Vendor Subtotal: | | | 100.39 |
| 9002-90-9020-44209 | AMAZON.COM | Carburetor | 01/28/2026 | 0 | 28.38 |
| | | Vendor Subtotal: | | | 28.38 |
| 9002-90-9020-44210 | AMAZON.COM | Dog Waste Bags | 01/28/2026 | 0 | 97.99 |
| | | Vendor Subtotal: | | | 97.99 |
| 9002-90-9020-44218 | AMAZON.COM | Dryer Door Switch | 01/28/2026 | 0 | 4.99 |

| | | | | | |
|--------------------|------------------------------|---|------------------|---|-----------------|
| | | | Vendor Subtotal: | | 4.99 |
| 9002-90-9020-44301 | CITY OF MUSCATINE | CH February Refuse | 02/01/2026 | 0 | 182.32 |
| | | | Vendor Subtotal: | | 182.32 |
| 9002-90-9020-44303 | THOMAS L SPANN JR & SONYA CO | Pest Control #511 | 01/29/2026 | 0 | 20.00 |
| 9002-90-9020-44303 | THOMAS L SPANN JR & SONYA CO | Pest Control #508 | 01/29/2026 | 0 | 20.00 |
| 9002-90-9020-44303 | THOMAS L SPANN JR & SONYA | CODOS 1-22-26 BB 804 | 01/29/2026 | 0 | 100.00 00032770 |
| 9002-90-9020-44303 | THOMAS L SPANN JR & SONYA | CODOS 1-8-26 CH 801 BB Treatment | 01/29/2026 | 0 | 100.00 00032645 |
| 9002-90-9020-44303 | THOMAS L SPANN JR & SONYA CO | Pest Control #509 | 01/29/2026 | 0 | 20.00 |
| 9002-90-9020-44303 | THOMAS L SPANN JR & SONYA | CODOS 1-8-26 CH 602 Initial BB | 01/29/2026 | 0 | 250.00 00032645 |
| 9002-90-9020-44303 | THOMAS L SPANN JR & SONYA | CO Pest Control #1101 | 01/29/2026 | 0 | 20.00 |
| 9002-90-9020-44303 | THOMAS L SPANN JR & SONYA | CO Pest Control #1102 | 01/29/2026 | 0 | 20.00 |
| 9002-90-9020-44303 | THOMAS L SPANN JR & SONYA | CO Pest Control #201 | 01/29/2026 | 0 | 20.00 |
| 9002-90-9020-44303 | THOMAS L SPANN JR & SONYA | CO Monthly Pest Control | 01/29/2026 | 0 | 50.00 |
| 9002-90-9020-44303 | THOMAS L SPANN JR & SONYA | CO Monthly Pest Control | 01/29/2026 | 0 | 50.00 |
| 9002-90-9020-44303 | THOMAS L SPANN JR & SONYA | CO Monthly Pest Control | 01/29/2026 | 0 | 100.00 |
| 9002-90-9020-44303 | THOMAS L SPANN JR & SONYA | CODOS 1-15-26 BB 306, 304 & 202 | 01/29/2026 | 0 | 300.00 00032698 |
| 9002-90-9020-44303 | THOMAS L SPANN JR & SONYA | CODOS 1-15-26 804 Infested Recliner Rem | 01/29/2026 | 0 | 100.00 00032703 |
| 9002-90-9020-44303 | THOMAS L SPANN JR & SONYA | CODOS 1-15-26 BB 1107, 806 & 706 | 01/29/2026 | 0 | 300.00 00032698 |
| 9002-90-9020-44303 | THOMAS L SPANN JR & SONYA | CODOS 1-15-26 BB 705, 405 & 403 | 01/29/2026 | 0 | 300.00 00032698 |
| 9002-90-9020-44303 | THOMAS L SPANN JR & SONYA | CODOS 1-22-26 BB tx 801 & 602 | 01/29/2026 | 0 | 200.00 00032770 |
| | | | Vendor Subtotal: | | 1,970.00 |
| 9002-90-9020-44306 | CITY OF MUSCATINE HOUSING RE | Verizon - Dec GPS Charges | 01/29/2026 | 0 | 17.05 |
| | | | Vendor Subtotal: | | 17.05 |
| 9002-90-9020-44310 | BETTENDORF N&S LOCK INC | Rekey Cylinder | 01/28/2026 | 0 | 799.20 |
| | | | Vendor Subtotal: | | 799.20 |
| 9002-90-9020-44318 | PDQ SUPPLY INC | Thermostat | 01/28/2026 | 0 | 83.00 |
| 9002-90-9020-44318 | PDQ SUPPLY INC | Thermostat | 01/28/2026 | 0 | 83.00 |
| | | | Vendor Subtotal: | | 166.00 |

| | | | | |
|--------------------|---|------------|---|------------|
| 9002-90-9020-45101 | CITY OF MUSCATINE HOUSING RE Liab/Prop/Umb Insurance | 01/29/2026 | 0 | 62,513.00 |
| | Vendor Subtotal: | | | 62,513.00 |
| 9002-90-9020-45103 | CITY OF MUSCATINE HOUSING RE Unemployment 1/16/25 | 01/28/2026 | 0 | 25.73 |
| | Vendor Subtotal: | | | 25.73 |
| 9002-90-9020-45104 | CITY OF MUSCATINE HOUSING RE Vehicle Insurance | 01/29/2026 | 0 | 526.00 |
| | Vendor Subtotal: | | | 526.00 |
| 9002-90-9020-45401 | CITY OF MUSCATINE HOUSING RE FICA 1/16/25 | 01/28/2026 | 0 | 622.53 |
| | Vendor Subtotal: | | | 622.53 |
| 9002-90-9020-45402 | CITY OF MUSCATINE HOUSING RE IPERS 1/16/25 | 01/28/2026 | 0 | 809.50 |
| | Vendor Subtotal: | | | 809.50 |
| 9002-90-9020-45403 | CITY OF MUSCATINE HOUSING RE Health Insurance 1/16/25 | 01/28/2026 | 0 | 3,818.36 |
| | Vendor Subtotal: | | | 3,818.36 |
| 9002-90-9020-45404 | CITY OF MUSCATINE HOUSING RE Life Insurance 1/16/25 | 01/28/2026 | 0 | 24.11 |
| | Vendor Subtotal: | | | 24.11 |
| 9002-90-9020-45405 | CITY OF MUSCATINE HOUSING RE Dental Insurance 1/16/25 | 01/28/2026 | 0 | 81.11 |
| | Vendor Subtotal: | | | 81.11 |
| 9002-90-9020-45406 | CITY OF MUSCATINE HOUSING RE LTD Insurance 1/16/25 | 01/28/2026 | 0 | 32.02 |
| 9002-90-9020-45406 | CITY OF MUSCATINE HOUSING RE LTD BW Insurance 1/16/25 | 01/28/2026 | 0 | 8.62 |
| | Vendor Subtotal: | | | 40.64 |
| | Subtotal for FUND: 9002 | | | 121,927.70 |

| | | | | | |
|--------------------|--|---------------------------------------|------------|---|-----------------|
| 9006-90-9060-41100 | CITY OF MUSCATINE HOUSING RE Admin Full-Time Wages 1/16/25 | | 01/28/2026 | 0 | 1,941.00 |
| 9006-90-9060-41100 | CITY OF MUSCATINE HOUSING RE Admin Longevity 1/16/25 | | 01/28/2026 | 0 | 2.60 |
| | Vendor Subtotal: | | | | 1,943.60 |
| 9006-90-9060-41701 | CITY OF MUSCATINE | FY 25/26 Accounting Fees | 01/29/2026 | 0 | 15,800.00 |
| | Vendor Subtotal: | | | | 15,800.00 |
| 9006-90-9060-41904 | CITY OF MUSCATINE HOUSING RE | Phone Allowance | 01/28/2026 | 0 | 3.00 |
| | Vendor Subtotal: | | | | 3.00 |
| 9006-90-9060-41908 | CITY OF MUSCATINE | IT Fees | 01/29/2026 | 0 | 800.00 |
| | Vendor Subtotal: | | | | 800.00 |
| 9006-90-9060-44100 | CITY OF MUSCATINE HOUSING RE Maint Full-Time Wages 1/16/25 | | 01/28/2026 | 0 | 2,430.61 |
| 9006-90-9060-44100 | CITY OF MUSCATINE HOUSING RE Maint Part-Time Wages 1/16/25 | | 01/28/2026 | 0 | 1,297.44 |
| 9006-90-9060-44100 | CITY OF MUSCATINE HOUSING RE Maint Longevity 1/16/25 | | 01/28/2026 | 0 | 21.45 |
| | Vendor Subtotal: | | | | 3,749.50 |
| 9006-90-9060-44203 | MENARDS (MUSC) | Reciprocating Saw | 01/28/2026 | 0 | 36.81 |
| | Vendor Subtotal: | | | | 36.81 |
| 9006-90-9060-44204 | MENARDS (MUSC) | Door Jam Kit | 01/28/2026 | 0 | 83.36 |
| | Vendor Subtotal: | | | | 83.36 |
| 9006-90-9060-44204 | AMAZON.COM | Lock Set | 01/29/2026 | 0 | 92.99 |
| | Vendor Subtotal: | | | | 92.99 |
| 9006-90-9060-44206 | PLUMB SUPPLY COMPANY | SS Toilet Seat Stock: 1500EC-000 BEMI | 01/28/2026 | 0 | 148.05 00032684 |
| 9006-90-9060-44206 | PLUMB SUPPLY COMPANY | SS Toilet Seat Stock: 500EC-000 BEMIS | 01/28/2026 | 0 | 111.56 00032684 |
| 9006-90-9060-44206 | PLUMB SUPPLY COMPANY | SS Toilet Seat Stock: 500EC-000 BEMIS | 01/28/2026 | 0 | 2.16 |

| | | | | | |
|--------------------|------------------------------|---------------------------------|------------------|---|-----------------|
| | | | Vendor Subtotal: | | 261.77 |
| 9006-90-9060-44206 | AMAZON.COM | Toilet Paper Holder | 01/28/2026 | 0 | 37.32 |
| | | | Vendor Subtotal: | | 37.32 |
| 9006-90-9060-44208 | KELLY HEATING COOLING & PLBC | Furnace Repair | 01/29/2026 | 0 | 90.00 |
| | | | Vendor Subtotal: | | 90.00 |
| 9006-90-9060-44301 | CITY OF MUSCATINE | SS February Refuse | 02/01/2026 | 0 | 320.00 |
| | | | Vendor Subtotal: | | 320.00 |
| 9006-90-9060-44303 | THOMAS L SPANN JR & SONYA CO | Pest Control #2700D | 01/29/2026 | 0 | 20.00 |
| 9006-90-9060-44303 | THOMAS L SPANN JR & SONYA CO | Pest Control #2900A | 01/29/2026 | 0 | 20.00 |
| 9006-90-9060-44303 | THOMAS L SPANN JR & SONYA CO | Pest Control #2812D | 01/29/2026 | 0 | 20.00 |
| | | | Vendor Subtotal: | | 60.00 |
| 9006-90-9060-44306 | CITY OF MUSCATINE HOUSING RE | Verizon - Dec GPS Charges | 01/29/2026 | 0 | 17.05 |
| | | | Vendor Subtotal: | | 17.05 |
| 9006-90-9060-44311 | KELLY HEATING COOLING & PLBC | Toilet Repair | 01/29/2026 | 0 | 200.00 |
| | | | Vendor Subtotal: | | 200.00 |
| 9006-90-9060-44313 | CITY OF MUSCATINE | Mowing July - Nov | 01/28/2026 | 0 | 4,750.00 |
| | | | Vendor Subtotal: | | 4,750.00 |
| 9006-90-9060-44315 | SAMUEL ANDERSON | SS 2812E Paint Rehab Walls Only | 01/28/2026 | 0 | 700.00 00032513 |
| | | | Vendor Subtotal: | | 700.00 |
| 9006-90-9060-45101 | CITY OF MUSCATINE HOUSING RE | Umberella Insurance | 01/29/2026 | 0 | 1,229.00 |

| | | | | |
|--------------------|---|------------|---|-----------|
| 9006-90-9060-45101 | CITY OF MUSCATINE HOUSING RE Property Insurance | 01/29/2026 | 0 | 20,486.00 |
| | Vendor Subtotal: | | | 21,715.00 |
| 9006-90-9060-45103 | CITY OF MUSCATINE HOUSING RE Unemployment 1/16/25 | 01/28/2026 | 0 | 17.08 |
| | Vendor Subtotal: | | | 17.08 |
| 9006-90-9060-45104 | CITY OF MUSCATINE HOUSING RE Vehicle Insurance | 01/29/2026 | 0 | 471.00 |
| | Vendor Subtotal: | | | 471.00 |
| 9006-90-9060-45401 | CITY OF MUSCATINE HOUSING RE FICA 1/16/25 | 01/28/2026 | 0 | 407.30 |
| 9006-90-9060-45401 | CITY OF MUSCATINE HOUSING RE Liability Insurance | 01/29/2026 | 0 | 5,079.00 |
| | Vendor Subtotal: | | | 5,486.30 |
| 9006-90-9060-45402 | CITY OF MUSCATINE HOUSING RE IPERS 1/16/25 | 01/28/2026 | 0 | 537.45 |
| | Vendor Subtotal: | | | 537.45 |
| 9006-90-9060-45403 | CITY OF MUSCATINE HOUSING RE Health Insurance 1/16/25 | 01/28/2026 | 0 | 3,444.06 |
| | Vendor Subtotal: | | | 3,444.06 |
| 9006-90-9060-45404 | CITY OF MUSCATINE HOUSING RE Life Insurance 1/16/25 | 01/28/2026 | 0 | 15.45 |
| | Vendor Subtotal: | | | 15.45 |
| 9006-90-9060-45405 | CITY OF MUSCATINE HOUSING RE Dental Insurance 1/16/25 | 01/28/2026 | 0 | 54.62 |
| | Vendor Subtotal: | | | 54.62 |
| 9006-90-9060-45406 | CITY OF MUSCATINE HOUSING RE LTD Insurance 1/16/25 | 01/28/2026 | 0 | 20.69 |
| 9006-90-9060-45406 | CITY OF MUSCATINE HOUSING RE LTD BW Insurance 1/16/25 | 01/28/2026 | 0 | 8.62 |
| | Vendor Subtotal: | | | 29.31 |

| | | | | | |
|--------------------|--|-----------------------------|------------|-------------------------|-----------|
| | | | | Subtotal for FUND: 9006 | 60,715.67 |
| 9007-90-9070-41100 | CITY OF MUSCATINE HOUSING RE Admin Full-Time Wages 1/16/25 | | 01/28/2026 | 0 | 5,575.63 |
| 9007-90-9070-41100 | CITY OF MUSCATINE HOUSING RE Admin Longevity 1/16/25 | | 01/28/2026 | 0 | 9.10 |
| | | | | Vendor Subtotal: | 5,584.73 |
| 9007-90-9070-41701 | CITY OF MUSCATINE | FY 25/26 Accounting Fees | 01/29/2026 | 0 | 29,000.00 |
| | | | | Vendor Subtotal: | 29,000.00 |
| 9007-90-9070-41902 | CITY OF MUSCATINE HOUSING RE Xerox - December Copies | | 01/29/2026 | 0 | 9.35 |
| | | | | Vendor Subtotal: | 9.35 |
| 9007-90-9070-41904 | CITY OF MUSCATINE HOUSING RE Phone Allowance | | 01/28/2026 | 0 | 1.50 |
| | | | | Vendor Subtotal: | 1.50 |
| 9007-90-9070-41908 | CITY OF MUSCATINE | IT Fees | 01/29/2026 | 0 | 4,700.00 |
| | | | | Vendor Subtotal: | 4,700.00 |
| 9007-90-9070-44301 | CITY OF MUSCATINE | Initial Inspections Q2 FY26 | 01/28/2026 | 0 | 1,820.00 |
| 9007-90-9070-44301 | CITY OF MUSCATINE | Re-Inspections Q2 FY26 | 01/28/2026 | 0 | 680.00 |
| | | | | Vendor Subtotal: | 2,500.00 |
| 9007-90-9070-45103 | CITY OF MUSCATINE HOUSING RE Unemployment 1/16/25 | | 01/28/2026 | 0 | 16.77 |
| | | | | Vendor Subtotal: | 16.77 |
| 9007-90-9070-45401 | CITY OF MUSCATINE HOUSING RE FICA 1/16/25 | | 01/28/2026 | 0 | 385.81 |
| | | | | Vendor Subtotal: | 385.81 |
| 9007-90-9070-45402 | CITY OF MUSCATINE HOUSING RE IPERS 1/16/25 | | 01/28/2026 | 0 | 527.19 |

| | | | | |
|--------------------|---|------------|------------------|----------|
| | | | Vendor Subtotal: | 527.19 |
| 9007-90-9070-45403 | CITY OF MUSCATINE HOUSING RE Health Insurance 1/16/25 | 01/28/2026 | 0 | 4,149.50 |
| | | | Vendor Subtotal: | 4,149.50 |
| 9007-90-9070-45404 | CITY OF MUSCATINE HOUSING RE Life Insurance 1/16/25 | 01/28/2026 | 0 | 18.29 |
| | | | Vendor Subtotal: | 18.29 |
| 9007-90-9070-45405 | CITY OF MUSCATINE HOUSING RE Dental Insurance 1/16/25 | 01/28/2026 | 0 | 72.83 |
| | | | Vendor Subtotal: | 72.83 |
| 9007-90-9070-45406 | CITY OF MUSCATINE HOUSING RE LTD Insurance 1/16/25 | 01/28/2026 | 0 | 32.98 |
| | | | Vendor Subtotal: | 32.98 |
| 9007-90-9070-47150 | HECTOR OR KIM CASTILLO New HAP J Goreham 16 of 31 Days Janu | 01/29/2026 | 0 | 101.00 |
| | | | Vendor Subtotal: | 101.00 |
| 9007-90-9070-47150 | DAN GANZER New HAP M Albert Full January | 01/29/2026 | 0 | 394.00 |
| | | | Vendor Subtotal: | 394.00 |
| 9007-90-9070-47150 | HARRISON LOFTS LLC New HAP J Valencia 24 of 31 Days Janu | 01/29/2026 | 0 | 685.00 |
| | | | Vendor Subtotal: | 685.00 |
| 9007-90-9070-47150 | JLTF LLC Other - A Hodges 24 of 31 Days January | 01/29/2026 | 0 | 302.00 |
| | | | Vendor Subtotal: | 302.00 |
| 9007-90-9071-41100 | CITY OF MUSCATINE HOUSING RE Admin Full-Time Wages 1/16/25 | 01/28/2026 | 0 | 1,574.80 |
| 9007-90-9071-41100 | CITY OF MUSCATINE HOUSING RE Admin Longevity 1/16/25 | 01/28/2026 | 0 | 6.50 |

| | | | | |
|--------------------|---|-------------------------|---|--------------|
| | | Vendor Subtotal: | | 1,581.30 |
| 9007-90-9071-45103 | CITY OF MUSCATINE HOUSING RE Unemployment 1/16/25 | 01/28/2026 | 0 | 4.77 |
| | | Vendor Subtotal: | | 4.77 |
| 9007-90-9071-45401 | CITY OF MUSCATINE HOUSING RE FICA 1/16/25 | 01/28/2026 | 0 | 110.39 |
| | | Vendor Subtotal: | | 110.39 |
| 9007-90-9071-45402 | CITY OF MUSCATINE HOUSING RE IPERS 1/16/25 | 01/28/2026 | 0 | 149.26 |
| | | Vendor Subtotal: | | 149.26 |
| 9007-90-9071-45403 | CITY OF MUSCATINE HOUSING RE Health Insurance 1/16/25 | 01/28/2026 | 0 | 1,063.77 |
| | | Vendor Subtotal: | | 1,063.77 |
| 9007-90-9071-45404 | CITY OF MUSCATINE HOUSING RE Life Insurance 1/16/25 | 01/28/2026 | 0 | 7.69 |
| | | Vendor Subtotal: | | 7.69 |
| 9007-90-9071-45405 | CITY OF MUSCATINE HOUSING RE Dental Insurance 1/16/25 | 01/28/2026 | 0 | 33.10 |
| | | Vendor Subtotal: | | 33.10 |
| | | Subtotal for FUND: 9007 | | 51,431.23 |
| | | Report Total: | | 1,276,792.23 |

BILLS FOR APPROVAL SUMMARY

February 4, 2026

Computer Bill Lists

| | | | |
|-------------------------------------|-----------------|-----------|---------------------|
| Regular Bills 1/7/26 | | \$ | 1,276,792.23 |
| Special Ck Run 1/20/26 | Operating | | 13,501.87 |
| Special Ck Run 1/23/26 | Operating | | 2,500.00 |
| Payroll Vendor Checks 1/30/26 | | | 7,338.82 |
| Payroll Vendor ACH Payments 1/30/26 | | | 98,110.92 |
| | Subtotal | \$ | 1,398,243.84 |

ACH Debit Memo Payments

| | | | |
|----------------------------|-----------------------------|-----------|-------------------|
| Wellmark Insurance | Health/Dental Insurance Jan | \$ | 83,000.00 |
| Wellmark Insurance | Health/Dental Insurance Jan | | 83,000.00 |
| Payroll Account | Transfer | | 498,166.71 |
| Treasurer State of Iowa | State Tax Withholding | | 23,890.75 |
| Treasurer State of Iowa | Sales Tax | | 14,878.98 |
| Internal Revenue Service | Federal Withholding | | 129,576.85 |
| Iowa Workforce Development | Unemployment | | 607.50 |
| | Subtotal | \$ | 833,120.79 |

Voucher Program

| | | | |
|-------------------|----------------------|-----------|--------------------|
| Various Landlords | Actual February Rent | \$ | (12,101.28) |
| | | \$ | (12,101.28) |

Voids

| | | | |
|----------------------|-----------------|-----------|--------------------|
| Void Checks 12/30/25 | Operating | \$ | (14,976.15) |
| | Subtotal | \$ | (14,976.15) |

Total Expenditures **\$** **2,204,287.20**

| | | | |
|-----------|----------------|-----------------------------|-----------|
| 1/30/2026 | ACH PAYROLL | MISSION SQUARE ICMA RETIRE | 12,339.03 |
| 1/30/2026 | ACH PAYROLL | MISSION SQUARE ICMA RC | 2,176.29 |
| 1/30/2026 | ACH PAYROLL | MUNICIPAL FIRE & POLICE INS | 79,640.60 |
| 1/30/2026 | ACH PAYROLL | NATIONWIDE | 3,955.00 |
| 1/30/2026 | PAYROLL CHECKS | AFA FLEX BILLING | 4,179.43 |
| 1/30/2026 | PAYROLL CHECKS | AFLAC | 525.88 |
| 1/30/2026 | PAYROLL CHECKS | ALLSTATE | 14.94 |
| 1/30/2026 | PAYROLL CHECKS | AMERICAN FIDELITY | 2,444.45 |
| 1/30/2026 | PAYROLL CHECKS | IDAHO CHILD SUPPORT | 99.12 |
| 1/30/2026 | PAYROLL CHECKS | UNITED WAY | 75.00 |
| 1/20/2026 | SPECIAL CHECKS | BARTH DONALD | 13,501.87 |
| 1/23/2026 | SPECIAL CHECKS | KUNDEL LAW OFFICE | 2,500.00 |



City of Muscatine

ITEM NUMBER

AGENDA ITEM SUMMARY

DATE: 2/3/2026

STAFF

April Limburg, City Planner

SUBJECT

Resolutions Accepting the Transfer of Five (5) County Held Tax Sale Certificates and Authorization to Pursue Obtaining Tax Sale Deeds

EXECUTIVE SUMMARY

Presented for Council consideration are five resolutions to accept the transfer of the county-owned Tax Sale Certificates for the properties located at 1805 Bryan Ave, 1114 Nebraska, 2003 Breese Ave, 1815 Schley, and Parcel ID 0825154030, and to authorize staff to take the necessary steps to obtain the tax sale deeds. The purpose of this proposed acquisition is to obtain the lots and work with area builders and non-profits to redevelop each parcel.

STAFF RECOMMENDATION

Staff recommends Council to adopt the resolutions.

BACKGROUND/DISCUSSION

Pursuant to Section 446.19, Code of Iowa, Muscatine County has become the holder 1805 Bryan Ave and parcel ID 0825154030, 1114 Nebraska, 2003 Breese Ave, and 1815 Schley.

Through property maintenance processes the City has expended \$11,800 on demolition in 2023 and \$6,832 for ongoing nuisance abatement; \$12,575 on demolition in 2021 and \$10,068 for ongoing nuisance abatement; \$8,900 on demolition in 2013 and \$22,552 for ongoing nuisance abatement; and \$17,562 for ongoing nuisance abatement, on each property respectively. It is unlikely a private entity will pay to acquire and redevelop the sites.

The County has assigned to the City of Muscatine the tax sale certificates and now the parcels are ready for the City to request the tax lien search and file the 90-day affidavit of service. Staff has been working with the County Attorney in this process to ensure the proper steps are taken to insure compliance with all laws and avoid any legal exposure to the City.

CITY FINANCIAL IMPACT

There is no additional financial impact to the general fund by this action. These properties are currently maintained by the City under nuisance codes. Obtaining title will make redevelopment of the sites more feasible.

ATTACHMENTS



City of Muscatine

ITEM NUMBER 2026-0040

AGENDA ITEM SUMMARY

DATE: 2/3/2026

STAFF

SUBJECT

Resolution Accepting the Tax Sale Certificate for 1114 Nebraska

EXECUTIVE SUMMARY

STAFF RECOMMENDATION

BACKGROUND/DISCUSSION

CITY FINANCIAL IMPACT

ATTACHMENTS

1. Nebraska
2. Resolution Council to accept the transfer - 1114 Nebraska

RESOLUTION #01-26-26-01
RESOLUTION ASSIGNING TAX SALE CERTIFICATE

WHEREAS, through the operation of Section 446.19, Code of Iowa, Muscatine County has become the holder of a certain Tax Sale Certificate to real estate in Muscatine County; and

WHEREAS, in obtaining the Tax Sale Certificate, the Muscatine County Treasurer has complied in all respects with the requirements of Chapters 446 and 447 of the Code; and

WHEREAS, Section 446.31, Code, grants to the County Board of Supervisors the authority to compromise the taxes owing and assign the Certificate to another; and

WHEREAS, Parcel No. 13-10-233-009, described more fully as follows:

Legal Description: 10-76-2W Lot 9 Blk 16 Smalley's Add S Musc
Street Address: 1114 Nebraska St
Deed/Title Holder: Mary F Morse

Was bid by Muscatine County tax sale held on June 19th, 2023 at a cost of \$9,591 and is currently held by the County as Tax Sale Certificate No. CH230001; and

WHEREAS, the City of Muscatine, Iowa has expressed an interest in acquiring the Tax Sale Certificate from the County; and

WHEREAS, the total amount of taxes owing is \$48,944, which includes tax, interest, cost and special assessments, and

WHEREAS, the Muscatine County Treasurer has recommended that this Tax Sale Certificate be assigned as described herein; and

WHEREAS, the Board of Supervisors finds the assignment of the Tax Sale Certificate under the conditions described herein to be in the public interest.

NOW, THEREFORE, BE IT RESOLVED by the Muscatine County Board of Supervisors:

Section 1. That the Tax Sale Certificate #CH230001 is hereby assigned to the City of Muscatine, Iowa; consideration for the assignment is ten dollars, provided, however, if sold in the future, the City will render to the County any proceeds of a sale of the property in excess of the demolition lien plus the actual cost incurred in acquiring title and selling the property.

Section 2. That such assignment shall be deemed effective upon payment by the assignee of the amount of \$10.00, to the Muscatine County Treasurer, receipt of which is hereby acknowledged, whereupon the Treasurer is authorized and directed to indicate the assignment of Tax Sale Certificate and to take those further steps mandated in Chapter 447 and 448, Code of Iowa.

Section 3. Upon issuance of Tax Sale Deed to the assignee, the Treasurer is authorized to abate all current and delinquent taxes outstanding on the parcel at the time of transfer.

PASSED AND APPROVED this 26th day of January, 2026.

ATTEST:



Tibe Vanderlinden
Muscatine County Auditor



Danny Chick, Chair
Muscatine County Board of Supervisors

RESOLUTION NO. _____

**A RESOLUTION ACCEPTING THE TRANSFER OF COUNTY HELD TAX SALE
CERTIFICATE & AUTHORIZATION TO PURSUE PROCESS TO OBTAIN TAX SALE
DEED FOR 1114 NEBRASKA STREET**

WHEREAS, through the operation of Section 446.19, Code of Iowa, Muscatine County has become the holder of a certain Tax Sale Certificate to real estate in Muscatine County; and

WHEREAS, in obtaining the Tax Sale Certificate, the Muscatine County Treasurer has complied in all respects with the requirements of Chapter 446 and 447 of the Code; and

WHEREAS, Section 446.31, Code of Iowa, grants to the County Board of Supervisors the authority to compromise the taxes owing and assign the Certificate to another; and

WHEREAS, Parcel No. 1310233009, described more fully as follows:

Legal Description: 10-76-2W Lot 9 Blk 16 Smalley's Add S Musc
City of Muscatine, County of Muscatine, State of Iowa.

Street Address: 1114 Nebraska St
Deed/Title Holder: Mary F Morse

Was bid by Muscatine County tax sale held on June 19, 2023, at a cost of \$9,591 and is currently held by the County as Tax Sale Certificate No. CH320001; and

WHEREAS, the City of Muscatine, Iowa, expended \$12,575 in the demolition of the structure formerly located on the parcel, and ongoing nuisance abatement costs of \$10,068, and has expressed an interest in acquiring the Tax Sale Certificate from the County in order to market the parcel and recoup the cost of demolition and nuisance abatement; and

WHEREAS, the total amount of taxes owing \$48,944, which includes tax, interest, cost, and special assessments; and

WHEREAS, the Muscatine County Treasurer has recommended that this Tax Sale Certificate be assigned as described herein; and

WHEREAS, the Board of Supervisors agrees to assign the Tax Sale Certificate # CH23001 to the City of Muscatine, Iowa; consideration for the assignment is one dollar, provided, however, that the City will render to the County any proceeds of the eventual sale of the property in excess of the demolition and nuisance abatement liens plus the actual costs incurred in acquiring title and selling the property. That such assignment shall be deemed effective upon payment by the assignee of the amount of \$1.00, to the Muscatine County Treasurer, whereupon the Treasurer is authorized and directed to indicate the assignment of the Tax Sale Certificate and to take those further steps mandated in Chapter 447 and 448, Code of Iowa; and

WHEREAS, City staff recommends accepting and acquiring said tax sale certificate and real estate; and

WHEREAS, the City Administrator is hereby authorized and directed to take the necessary steps and process to obtain the Tax Sale Deed for the City for purposes of then offering the above-described real estate for sale to the public to be followed by appropriate action of the City Council as provided by law.

NOW, THEREFORE, BE IT RESOLVED BY THE CITY COUNCIL OF THE CITY OF MUSCATINE, IOWA, that the resolution to accept the transfer of a certain county held Tax Sale Certificate, to authorize the City Administrator to take the necessary steps to obtain the Tax Sale Deed for the property for purposes of then selling the above-described real estate is hereby approved.

PASSED, APPROVED AND ADOPTED this 3rd day of February 2026.

**BY THE CITY COUNCIL OF THE
CITY OF MUSCATINE, IOWA**

Brad Bark, Mayor

Attest:

Cinda Hilger, City Clerk



City of Muscatine

ITEM NUMBER 2026-0041

AGENDA ITEM SUMMARY

DATE: 2/3/2026

STAFF

SUBJECT

Resolution Accepting the Tax Sale Certificate for 1815 Schley

EXECUTIVE SUMMARY

STAFF RECOMMENDATION

BACKGROUND/DISCUSSION

CITY FINANCIAL IMPACT

ATTACHMENTS

1. Schley
2. Resolution Council to accept the transfer - 1815 Schley

RESOLUTION #01-26-26-04
RESOLUTION ASSIGNING TAX SALE CERTIFICATE

WHEREAS, through the operation of Section 446.19, Code of Iowa, Muscatine County has become the holder of a certain Tax Sale Certificate to real estate in Muscatine County; and

WHEREAS, in obtaining the Tax Sale Certificate, the Muscatine County Treasurer has complied in all respects with the requirements of Chapters 446 and 447 of the Code; and

WHEREAS, Section 446.31, Code, grants to the County Board of Supervisors the authority to compromise the taxes owing and assign the Certificate to another; and

WHEREAS, Parcel No. 13-10-276-009, described more fully as follows:

Legal Description: 10-76-2W S 50- Lot 10 Blk 21 Smalley's Add S Musc
Street Address: 1815 Schley Ave
Deed/Title Holder: Evelyn C Phillips - Deed; Timothy M or Mindy S McCormick - Contract

Was bid by Muscatine County tax sale held on June 18, 2018 at a cost of \$3,375 and is currently held by the County as Tax Sale Certificate No. CH180216; and

WHEREAS, the City of Muscatine, Iowa has expressed an interest in acquiring the Tax Sale Certificate from the County; and

WHEREAS, the total amount of taxes owing is \$41,264, which includes tax, interest, cost and special assessments, and

WHEREAS, the Muscatine County Treasurer has recommended that this Tax Sale Certificate be assigned as described herein; and

WHEREAS, the Board of Supervisors finds the assignment of the Tax Sale Certificate under the conditions described herein to be in the public interest.

NOW, THEREFORE, BE IT RESOLVED by the Muscatine County Board of Supervisors:

Section 1. That the Tax Sale Certificate #CH180216 is hereby assigned to the City of Muscatine, Iowa; consideration for the assignment is ten dollars, provided, however, if sold in the future, the City will render to the County any proceeds of a sale of the property in excess of the demolition lien plus the actual cost incurred in acquiring title and selling the property.

Section 2. That such assignment shall be deemed effective upon payment by the assignee of the amount of \$10.00, to the Muscatine County Treasurer, receipt of which is hereby acknowledged, whereupon the Treasurer is authorized and directed to indicate the assignment of Tax Sale Certificate and to take those further steps mandated in Chapter 447 and 448, Code of Iowa.

Section 3. Upon issuance of Tax Sale Deed to the assignee, the Treasurer is authorized to abate all current and delinquent taxes outstanding on the parcel at the time of transfer.

PASSED AND APPROVED this 26th day of January, 2026.

ATTEST:



Tibe Vanderlinden
Muscatine County Auditor



Danny Chick, Chair
Muscatine County Board of Supervisors

RESOLUTION NO. _____

**A RESOLUTION ACCEPTING THE TRANSFER OF COUNTY HELD TAX SALE
CERTIFICATE & AUTHORIZATION TO PURSUE PROCESS TO OBTAIN TAX SALE
DEED FOR 1815 SCHLEY AVENUE**

WHEREAS, through the operation of Section 446.19, Code of Iowa, Muscatine County has become the holder of a certain Tax Sale Certificate to real estate in Muscatine County; and

WHEREAS, in obtaining the Tax Sale Certificate, the Muscatine County Treasurer has complied in all respects with the requirements of Chapter 446 and 447 of the Code; and

WHEREAS, Section 446.31, Code of Iowa, grants to the County Board of Supervisors the authority to compromise the taxes owing and assign the Certificate to another; and

WHEREAS, Parcel No. 131027600, described more fully as follows:

Legal Description: 10-76-2W S 50- Lot 10 Blk 21 Smalley's Add S Musc
City of Muscatine, County of Muscatine, State of Iowa.

Street Address: 1815 Schley Ave, Muscatine, Iowa

Deed/Title Holder: Evelyn C Phillips – Deed: Timothy M or Mind S McCormick –
Contract

Was bid by Muscatine County tax sale held on June 18, 2018, at a cost of \$3,375 and is currently held by the County as Tax Sale Certificate No. CH180216; and

WHEREAS, the City of Muscatine, Iowa, expended an unknown amount in the demolition of the structure formerly located on the parcel, and ongoing nuisance abatements costs of \$17,562, and has expressed an interest in acquiring the Tax Sale Certificate from the County in order to market the parcel and recoup the cost of demolition and nuisance abatement; and

WHEREAS, the total amount of taxes owing \$41,264, which includes taxes, interest, cost, and special assessments; and

WHEREAS, the Muscatine County Treasurer has recommended that this Tax Sale Certificate be assigned as described herein; and

WHEREAS, the Board of Supervisors agrees to assign the Tax Sale Certificate #CH180216 to the City of Muscatine, Iowa; consideration for the assignment is one dollar, provided, however, that the City will render to the County any proceeds of the eventual sale of the property in excess of the demolition and nuisance abatement liens plus the actual costs incurred in acquiring title and selling the property. That such assignment shall be deemed effective upon payment by the assignee of the amount of \$1.00, to the Muscatine County Treasurer, whereupon

the Treasurer is authorized and directed to indicate the assignment of the Tax Sale Certificate and to take those further steps mandated in Chapter 447 and 448, Code of Iowa; and

WHEREAS, City staff recommends accepting and acquiring said tax sale certificate and real estate; and

WHEREAS, the City Administrator is hereby authorized and directed to take the necessary steps and process to obtain the Tax Sale Deed for the City for purposes of then offering the above-described real estate for sale to the public to be followed by appropriate action of the City Council as provided by law.

NOW, THEREFORE, BE IT RESOLVED BY THE CITY COUNCIL OF THE CITY OF MUSCATINE, IOWA, that the resolution to accept the transfer of a certain county held Tax Sale Certificate, to authorize the City Administrator to take the necessary steps to obtain the Tax Sale Deed for the property for purposes of then selling the above-described real estate is hereby approved.

PASSED, APPROVED AND ADOPTED this 3rd day of February 2026.

**BY THE CITY COUNCIL OF THE
CITY OF MUSCATINE, IOWA**

Brad Bark, Mayor

Attest:

Cinda Hilger, City Clerk



City of Muscatine

ITEM NUMBER 2026-0042

AGENDA ITEM SUMMARY

DATE: 2/3/2026

STAFF

SUBJECT

Resolution Accepting Tax Sale Certificate for Parcel ID 0825154030

EXECUTIVE SUMMARY

STAFF RECOMMENDATION

BACKGROUND/DISCUSSION

CITY FINANCIAL IMPACT

ATTACHMENTS

1. Jackson 1
2. Resolution Council to accept the transfer - Parcel 0825154030

RESOLUTION #01-26-26-03
RESOLUTION ASSIGNING TAX SALE CERTIFICATE

WHEREAS, through the operation of Section 446.19, Code of Iowa, Muscatine County has become the holder of a certain Tax Sale Certificate to real estate in Muscatine County; and

WHEREAS, in obtaining the Tax Sale Certificate, the Muscatine County Treasurer has complied in all respects with the requirements of Chapters 446 and 447 of the Code; and

WHEREAS, Section 446.31, Code, grants to the County Board of Supervisors the authority to compromise the taxes owing and assign the Certificate to another; and

WHEREAS, Parcel No. 08-25-154-030, described more fully as follows:

Legal Description: 25-77-2W Lots 27 & 28 Blk 30 Park Place Add
Street Address:
Deed/Title Holder: Bruce Jackson

Was bid by Muscatine County tax sale held on June 20, 2022 at a cost of \$5,016 and is currently held by the County as Tax Sale Certificate No. CH22003; and

WHEREAS, the City of Muscatine, Iowa has expressed an interest in acquiring the Tax Sale Certificate from the County; and

WHEREAS, the total amount of taxes owing is \$11,445, which includes tax, interest, cost and special assessments, and

WHEREAS, the Muscatine County Treasurer has recommended that this Tax Sale Certificate be assigned as described herein; and

WHEREAS, the Board of Supervisors finds the assignment of the Tax Sale Certificate under the conditions described herein to be in the public interest.

NOW, THEREFORE, BE IT RESOLVED by the Muscatine County Board of Supervisors:

Section 1. That the Tax Sale Certificate #CH22003 is hereby assigned to the City of Muscatine, Iowa; consideration for the assignment is ten dollars, provided, however, if sold in the future, the City will render to the County any proceeds of a sale of the property in excess of the demolition lien plus the actual cost incurred in acquiring title and selling the property.

Section 2. That such assignment shall be deemed effective upon payment by the assignee of the amount of \$10.00, to the Muscatine County Treasurer, receipt of which is hereby acknowledged, whereupon the Treasurer is authorized and directed to indicate the assignment of Tax Sale Certificate and to take those further steps mandated in Chapter 447 and 448, Code of Iowa.

Section 3. Upon issuance of Tax Sale Deed to the assignee, the Treasurer is authorized to abate all current and delinquent taxes outstanding on the parcel at the time of transfer.

PASSED AND APPROVED this 26th day of January, 2026.

ATTEST:



Tibe Vanderlinden
Muscatine County Auditor



Danny Chick, Chair
Muscatine County Board of Supervisors

RESOLUTION NO. _____

**A RESOLUTION ACCEPTING THE TRANSFER OF COUNTY HELD TAX SALE
CERTIFICATE & AUTHORIZATION TO PURSUE PROCESS TO OBTAIN TAX SALE
DEED FOR PARCEL 0825154030**

WHEREAS, through the operation of Section 446.19, Code of Iowa, Muscatine County has become the holder of a certain Tax Sale Certificate to real estate in Muscatine County; and

WHEREAS, in obtaining the Tax Sale Certificate, the Muscatine County Treasurer has complied in all respects with the requirements of Chapter 446 and 447 of the Code; and

WHEREAS, Section 446.31, Code of Iowa, grants to the County Board of Supervisors the authority to compromise the taxes owing and assign the Certificate to another; and

WHEREAS, Parcel No. 0825154030, described more fully as follows:

Legal Description: 25-77-2W Lot 27 & 28 BLK 30 Park Place Add

City of Muscatine, County of Muscatine, State of Iowa.

Street Address: 1805 Bryan Ave

Deed/Title Holder: Bruce Jackson

Was bid by Muscatine County tax sale held on June 20, 2022, at a cost of \$5,016 and is currently held by the County as Tax Sale Certificate No. CH22003; and

WHEREAS, the City of Muscatine, Iowa, expended has expressed an interest in acquiring the Tax Sale Certificate from the County in order to market the parcel and recoup the cost of demolition and nuisance abatement; and

WHEREAS, the total amount of taxes owing \$11,445, which includes tax, interest, cost, and special assessments; and

WHEREAS, the Muscatine County Treasurer has recommended that this Tax Sale Certificate be assigned as described herein; and

WHEREAS, the Board of Supervisors agrees to assign the Tax Sale Certificate #CH22003 to the City of Muscatine, Iowa; consideration for the assignment is one dollar, provided, however, that the City will render to the County any proceeds of the eventual sale of the property in excess of the nuisance abatement liens plus the actual costs incurred in acquiring title and selling the property. That such assignment shall be deemed effective upon payment by the assignee of the amount of \$1.00, to the Muscatine County Treasurer, whereupon the Treasurer is authorized and directed to indicate the assignment of the Tax Sale Certificate and to take those further steps mandated in Chapter 447 and 448, Code of Iowa; and

WHEREAS, city staff recommends accepting and acquiring said tax sale certificate and real estate; and

WHEREAS, The City Administrator is hereby authorized and directed to take the necessary steps and processes to obtain the Tax Sale Deed for the City for purposes of then offering the above-described real estate for sale to the public to be followed by appropriate action of the City Council as provided by law.

NOW, THEREFORE, BE IT RESOLVED BY THE CITY COUNCIL OF THE CITY OF MUSCATINE, IOWA, that the resolution to accept the transfer of a certain county held Tax Sale Certificate, to authorize the City Administrator to take the necessary steps to obtain the Tax Sale Deed for the property for purposes of then selling the above-described real estate is hereby approved.

PASSED, APPROVED AND ADOPTED this 3rd day of February 2026.

**BY THE CITY COUNCIL OF THE
CITY OF MUSCATINE, IOWA**

Brad Bark, Mayor

Attest:

Cinda Hilger, City Clerk



City of Muscatine

ITEM NUMBER 2026-0043

AGENDA ITEM SUMMARY

DATE: 2/3/2026

STAFF

SUBJECT

Resolution Accepting Tax Sale Certificate for 2003 Breese

EXECUTIVE SUMMARY

STAFF RECOMMENDATION

BACKGROUND/DISCUSSION

CITY FINANCIAL IMPACT

ATTACHMENTS

1. Breese
2. Resolution Council to accept the transfer - 2003 Breese Ave

RESOLUTION #01-26-26-05
RESOLUTION ASSIGNING TAX SALE CERTIFICATE

WHEREAS, through the operation of Section 446.19, Code of Iowa, Muscatine County has become the holder of a certain Tax Sale Certificate to real estate in Muscatine County; and

WHEREAS, in obtaining the Tax Sale Certificate, the Muscatine County Treasurer has complied in all respects with the requirements of Chapters 446 and 447 of the Code; and

WHEREAS, Section 446.31, Code, grants to the County Board of Supervisors the authority to compromise the taxes owing and assign the Certificate to another; and

WHEREAS, Parcel No. 13-03-452-007, described more fully as follows:

Legal Description: 3-76-2W Lots 6 & 7 Blk 6 S Park Add
Street Address: 2003 Breese Ave
Deed/Title Holder: Residential Equity Partners LLC

Was bid by Muscatine County tax sale held on June 18th, 2018 at a cost of \$4,749 and is currently held by the County as Tax Sale Certificate No. CH180217; and

WHEREAS, the City of Muscatine, Iowa has expressed an interest in acquiring the Tax Sale Certificate from the County; and

WHEREAS, the total amount of taxes owing is \$56,304, which includes tax, interest, cost and special assessments, and

WHEREAS, the Muscatine County Treasurer has recommended that this Tax Sale Certificate be assigned as described herein; and

WHEREAS, the Board of Supervisors finds the assignment of the Tax Sale Certificate under the conditions described herein to be in the public interest.

NOW, THEREFORE, BE IT RESOLVED by the Muscatine County Board of Supervisors:

Section 1. That the Tax Sale Certificate #CH180217 is hereby assigned to the City of Muscatine, Iowa; consideration for the assignment is ten dollars, provided, however, if sold in the future, the City will render to the County any proceeds of a sale of the property in excess of the demolition lien plus the actual cost incurred in acquiring title and selling the property.

Section 2. That such assignment shall be deemed effective upon payment by the assignee of the amount of \$10.00, to the Muscatine County Treasurer, receipt of which is hereby acknowledged, whereupon the Treasurer is authorized and directed to indicate the assignment of Tax Sale Certificate and to take those further steps mandated in Chapter 447 and 448, Code of Iowa.

Section 3. Upon issuance of Tax Sale Deed to the assignee, the Treasurer is authorized to abate all current and delinquent taxes outstanding on the parcel at the time of transfer.

PASSED AND APPROVED this 26th day of January, 2026.

ATTEST:



Tibe Vanderlinden
Muscatine County Auditor



Danny Chick, Chair
Muscatine County Board of Supervisors

RESOLUTION NO. _____

**A RESOLUTION ACCEPTING THE TRANSFER OF COUNTY HELD TAX SALE
CERTIFICATE & AUTHORIZATION TO PURSUE PROCESS TO OBTAIN TAX SALE
DEED FOR 2003 BREESE AVENUE**

WHEREAS, through the operation of Section 446.19, Code of Iowa, Muscatine County has become the holder of a certain Tax Sale Certificate to real estate in Muscatine County; and

WHEREAS, in obtaining the Tax Sale Certificate, the Muscatine County Treasurer has complied in all respects with the requirements of Chapter 446 and 447 of the Code; and

WHEREAS, Section 446.31, Code of Iowa, grants to the County Board of Supervisors the authority to compromise the taxes owing and assign the Certificate to another; and

WHEREAS, Parcel No. 1303452007, described more fully as follows:

Legal Description: 3-76-2W Lots 6 & 7 Blk 6 S Park Add
City of Muscatine, County of Muscatine, State of Iowa.

Street Address: 2003 Breese Ave
Deed/Title Holder: Residential Equity Partners LLC

Was bid by Muscatine County tax sale held on June 18, 2018, at a cost of \$4,749 and is currently held by the County as Tax Sale Certificate No. CH180217; and

WHEREAS, the City of Muscatine, Iowa, expended \$8,900 in the demolition of the structure formerly located on the parcel, and ongoing nuisance abatements costs of \$22,552, and has expressed an interest in acquiring the Tax Sale Certificate from the County in order to market the parcel and recoup the cost of demolition and nuisance abatement; and

WHEREAS, the total amount of taxes owing \$56,304, which includes taxes, interest, cost, and special assessments; and

WHEREAS, the Muscatine County Treasurer has recommended that this Tax Sale Certificate be assigned as described herein; and

WHEREAS, the Board of Supervisors agrees to assign the Tax Sale Certificate # CH180217 to the City of Muscatine, Iowa; consideration for the assignment is one dollar, provided, however, that the City will render to the County any proceeds of the eventual sale of the property in excess of the demolition and nuisance abatement liens plus the actual costs incurred in acquiring title and selling the property. That such assignment shall be deemed effective upon payment by the assignee of the amount of \$1.00, to the Muscatine County Treasurer, whereupon the Treasurer is authorized and directed to indicate the assignment of the Tax Sale Certificate and to take those further steps mandated in Chapter 447 and 448, Code of Iowa; and

WHEREAS, City staff recommends accepting and acquiring said tax sale certificate and real estate; and

WHEREAS, the City Administrator is hereby authorized and directed to take the necessary steps and process to obtain the Tax Sale Deed for the City for purposes of then offering the above-described real estate for sale to the public to be followed by appropriate action of the City Council as provided by law.

NOW, THEREFORE, BE IT RESOLVED BY THE CITY COUNCIL OF THE CITY OF MUSCATINE, IOWA, that the resolution to accept the transfer of a certain county held Tax Sale Certificate, to authorize the City Administrator to take the necessary steps to obtain the Tax Sale Deed for the property for purposes of then selling the above-described real estate is hereby approved.

PASSED, APPROVED AND ADOPTED this 3rd day of February 2026.

**BY THE CITY COUNCIL OF THE
CITY OF MUSCATINE, IOWA**

Brad Bark, Mayor

Attest:

Cinda Hilger, City Clerk



City of Muscatine

ITEM NUMBER 2026-0044

AGENDA ITEM SUMMARY

DATE: 2/3/2026

STAFF

SUBJECT

Resolution Accepting Tax Sale Certificate for 1805 Bryan Ave

EXECUTIVE SUMMARY

STAFF RECOMMENDATION

BACKGROUND/DISCUSSION

CITY FINANCIAL IMPACT

ATTACHMENTS

1. Jackson 2
2. Resolution Council to accept the transfer - 1805 Bryan Ave

RESOLUTION #01-26-26-02
RESOLUTION ASSIGNING TAX SALE CERTIFICATE

WHEREAS, through the operation of Section 446.19, Code of Iowa, Muscatine County has become the holder of a certain Tax Sale Certificate to real estate in Muscatine County; and

WHEREAS, in obtaining the Tax Sale Certificate, the Muscatine County Treasurer has complied in all respects with the requirements of Chapters 446 and 447 of the Code; and

WHEREAS, Section 446.31, Code, grants to the County Board of Supervisors the authority to compromise the taxes owing and assign the Certificate to another; and

WHEREAS, Parcel No. 08-25-154-029, described more fully as follows:

Legal Description: 25-77-2W Lot 26 Blk 30 Park Place Add
Street Address: 1805 Bryan Ave
Deed/Title Holder: Bruce Jackson

Was bid by Muscatine County tax sale held on June 20, 2022 at a cost of \$11,801 and is currently held by the County as Tax Sale Certificate No. CH22002; and

WHEREAS, the City of Muscatine, Iowa has expressed an interest in acquiring the Tax Sale Certificate from the County; and

WHEREAS, the total amount of taxes owing is \$50,783, which includes tax, interest, cost and special assessments, and

WHEREAS, the Muscatine County Treasurer has recommended that this Tax Sale Certificate be assigned as described herein; and

WHEREAS, the Board of Supervisors finds the assignment of the Tax Sale Certificate under the conditions described herein to be in the public interest.

NOW, THEREFORE, BE IT RESOLVED by the Muscatine County Board of Supervisors:

Section 1. That the Tax Sale Certificate #CH22002 is hereby assigned to the City of Muscatine, Iowa; consideration for the assignment is ten dollars, provided, however, if sold in the future, the City will render to the County any proceeds of a sale of the property in excess of the demolition lien plus the actual cost incurred in acquiring title and selling the property.

Section 2. That such assignment shall be deemed effective upon payment by the assignee of the amount of \$10.00, to the Muscatine County Treasurer, receipt of which is hereby acknowledged, whereupon the Treasurer is authorized and directed to indicate the assignment of Tax Sale Certificate and to take those further steps mandated in Chapter 447 and 448, Code of Iowa.

Section 3. Upon issuance of Tax Sale Deed to the assignee, the Treasurer is authorized to abate all current and delinquent taxes outstanding on the parcel at the time of transfer.

PASSED AND APPROVED this 26th day of January, 2026.

ATTEST:



Tibe Vanderlinden
Muscatine County Auditor



Danny Chick, Chair
Muscatine County Board of Supervisors

RESOLUTION NO. _____

**A RESOLUTION ACCEPTING THE TRANSFER OF COUNTY HELD TAX SALE
CERTIFICATE & AUTHORIZATION TO PURSUE PROCESS TO OBTAIN TAX SALE
DEED FOR 1805 BRYAN AVENUE**

WHEREAS, through the operation of Section 446.19, Code of Iowa, Muscatine County has become the holder of a certain Tax Sale Certificate to real estate in Muscatine County; and

WHEREAS, in obtaining the Tax Sale Certificate, the Muscatine County Treasurer has complied in all respects with the requirements of Chapter 446 and 447 of the Code; and

WHEREAS, Section 446.31, Code of Iowa, grants to the County Board of Supervisors the authority to compromise the taxes owing and assign the Certificate to another; and

WHEREAS, Parcel No. 0825154029, described more fully as follows:

Legal Description: 25-77-2W Lot 26 BLK 30 Park Place Add
City of Muscatine, County of Muscatine, State of Iowa.

Street Address: 1805 Bryan Ave, Muscatine, Iowa
Deed/Title Holder: Bruce Jackson

Was bid by Muscatine County tax sale held on June 20, 2022, at a cost of \$11,801 and is currently held by the County as Tax Sale Certificate No. CH22002; and

WHEREAS, the City of Muscatine, Iowa, expended \$11,875 in the demolition of the structure formerly located on the parcel, and ongoing nuisance abatements costs of \$6,832, and has expressed an interest in acquiring the Tax Sale Certificate from the County in order to market the parcel and recoup the cost of demolition and nuisance abatement; and

WHEREAS, the total amount of taxes owing \$50,783, which includes tax, interest, cost, and special assessments; and

WHEREAS, the Muscatine County Treasurer has recommended that this Tax Sale Certificate be assigned as described herein; and

WHEREAS, the Board of Supervisors agrees to assign the Tax Sale Certificate # CH22002 to the City of Muscatine, Iowa; consideration for the assignment is one dollar, provided, however, that the City will render to the County any proceeds of the eventual sale of the property in excess of the demolition and nuisance abatement liens plus the actual costs incurred in acquiring title and selling the property. That such assignment shall be deemed effective upon payment by the assignee of the amount of \$1.00, to the Muscatine County Treasurer, whereupon the Treasurer is authorized and directed to indicate the assignment of the Tax Sale Certificate and to take those further steps mandated in Chapter 447 and 448, Code of Iowa; and

WHEREAS, city staff recommends accepting and acquiring said tax sale certificate and real estate; and

WHEREAS, The City Administrator is hereby authorized and directed to take the necessary steps and process to obtain the Tax Sale Deed for the City for purposes of then offering the above-described real estate for sale to the public to be followed by appropriate action of the City Council as provided by law.

NOW, THEREFORE, BE IT RESOLVED BY THE CITY COUNCIL OF THE CITY OF MUSCATINE, IOWA, that the resolution to accept the transfer of a certain county held Tax Sale Certificate, to authorize the City Administrator to take the necessary steps to obtain the Tax Sale Deed for the property for purposes of then selling the above-described real estate is hereby approved.

PASSED, APPROVED AND ADOPTED this 3rd day of February 2026.

**BY THE CITY COUNCIL OF THE
CITY OF MUSCATINE, IOWA**

Brad Bark, Mayor

Attest:

Cinda Hilger, City Clerk



City of Muscatine

ITEM NUMBER 2026-0048

AGENDA ITEM SUMMARY

DATE: 2/3/2026

STAFF

LeAnna McCullough, Interim Finance Director
Nancy Lueck, Former Finance Director

SUBJECT

Resolution Setting a Public Hearing For February 17, 2026, on a Proposal to Enter into a Sewer Revenue Loan and Disbursement Agreement and to Borrow Money Thereunder in a Principal Amount not to Exceed \$3,380,000 (Planning and Design Loan)

EXECUTIVE SUMMARY

Water Pollution Control Plant (WPCP) and Lift Station Electrical Asset Replacement Project: The WPCP Facilities Plan completed in 2022/2023 identified upgrades at the WPCP and the lift stations as priority projects. The WPCP and Lift Station Electrical Asset Replacement project is estimated to have a total cost of up to \$7 million. Engineering design for this project began in 2024/2025 and is continuing in fiscal year 2025/2026.

This project will be financed through the State Revolving Fund (SRF) Loan Program. Under the SRF Loan Program, local governments can initially apply for and receive a Planning & Design (P&D) Loan. Under the terms of the P&D loan, there is no interest incurred by the City during the initial phase of the project. Once the project is bid and goes out for construction, the P&D Loan will be rolled into the permanent SRF Loan for this project. Interest starts to be incurred once the City closes on the final SRF loan and begins drawing down funds under the permanent SRF loan. Sewer revenues will be used to fund principal and interest payments on the final SRF loan.

At this time, it is necessary to set and hold a public hearing on the SRF Planning and Design loan for the Water Pollution Control Plant (WPCP) and Lift Station Electrical Asset Replacement Project. The Planning and Design Loan is estimated at \$3,380,000. This amount includes project engineering, equipment to be ordered prior to beginning the project, and related initial planning and design costs.

The attached Resolution will set the public hearing on the Planning & Design Loan for February 17, 2026, at 5:30 p.m.

STAFF RECOMMENDATION

Staff recommends approval of this Resolution.

BACKGROUND/DISCUSSION

The WPCP Facilities Plan completed in 2022/2023 identified upgrades at the WPCP and the lift stations as priority projects. The WPCP and Lift Station Electrical Asset Replacement project is estimated to have a total cost of up to \$7 million. Engineering design for this project began in 2024/2025 and is continuing in fiscal year 2025/2026.

This project will be financed through the State Revolving Fund (SRF) Loan Program. Under the SRF Loan Program, local governments can initially apply for and receive a Planning & Design (P&D) Loan. Under the terms of the P&D loan, there is no interest incurred by the City during the initial P&D phase of the project. Once the project is bid and goes out for construction, the P&D Loan will be rolled into the permanent SRF Loan for this project. Interest starts to be incurred once the City closes on the final SRF loan and begins drawing down funds from the permanent SRF loan. Sewer revenues will be used to fund principal and interest payments on the final SRF loan.

At this time, it is necessary to set and hold a public hearing on the SRF Loan for the Planning and Design phase of the Water Pollution Control Plant (WPCP) and Lift Station Electrical Asset Replacement Project. The Planning and Design Loan is estimated at \$3,380,000. This amount includes project engineering, equipment to be ordered prior to beginning construction of the project, and related initial project costs.

The attached Resolution will set the public hearing on the Planning & Design Loan for February 17, 2026, at 5:30 p.m.

CITY FINANCIAL IMPACT

The last sewer rate study was completed in 2023, which set sewer rates for the following five years from July 1, 2023, through July 1, 2027. The rate study recommended 3% annual increases in the sewer rates and took into consideration upcoming capital projects, including the Water Pollution Control Plant (WPCP) and Lift Station Electrical Asset Replacement Project

ATTACHMENTS

- 1. 1st Half Set Hrg Sewer Rev LDA (Muscatine 421464-82) 2026 (1)

MINUTES TO SET DATE FOR HEARING
ON ENTERING INTO A LOAN AND
DISBURSEMENT AGREEMENT

421464-82 (N/I)

Muscatine, Iowa

February 3, 2026

The City Council of the City of Muscatine, Iowa, met on February 3, 2026, at _____
o'clock ____m., at the _____, in the City. The Mayor presided and the
roll was called showing the following members of the Council present and absent:

Present: _____

Absent: _____.

Council Member _____ introduced the resolution hereinafter next set
out and moved its adoption, seconded by Council Member _____; and after
due consideration thereof by the Council, the Mayor put the question upon the adoption of the
said resolution and the roll being called, the following named Council Members voted:

Ayes: _____

Nays: _____.

Whereupon, the Mayor declared the resolution duly adopted as follows:

RESOLUTION NO. 2026-0048

Resolution to fix a date for a public hearing on proposal to enter into a Sewer Revenue Loan and Disbursement Agreement and to borrow money thereunder in a principal amount not to exceed \$3,380,000

WHEREAS, the City of Muscatine (the “City”), in Muscatine County, State of Iowa, did heretofore establish a Municipal Sanitary Sewer System (the “Utility”) in and for the City which has continuously supplied sanitary sewer service in and to the City and its inhabitants since its establishment; and

WHEREAS, the management and control of the Utility are vested in the City Council (the “Council”) and no board of trustees exists for this purpose; and

WHEREAS, pursuant to a prior resolution of the Council (the “Outstanding Bond Resolution”), the City has heretofore issued its \$16,500,000 Sewer Revenue Bond, SRF Series 2008, dated November 5, 2008 (the “Outstanding Bond”), a portion of which remains outstanding; and

WHEREAS, pursuant to the Outstanding Bond Resolution, the City reserved the right to issue additional obligations payable from the net revenues of the Utility and ranking on a parity with the Outstanding Bond under the terms and conditions set forth in the Outstanding Bond Resolution; and

WHEREAS, the City now proposes to enter into a Sewer Revenue Loan and Disbursement Agreement (the “Agreement”) and to borrow money thereunder in a principal amount not to exceed \$3,380,000, pursuant to the provisions of Section 384.24A of the Code of Iowa, for the purpose of paying the cost, to that extent, of planning, designing and constructing improvements and extensions to the Utility (the “Project”), and it is necessary to fix a date of meeting of the City Council at which it is proposed to take action to enter into the Agreement and to give notice thereof as required by such law;

NOW, THEREFORE, Be It Resolved by the City Council of the City of Muscatine, Iowa, as follows:

Section 1. This City Council shall meet on February 17, 2026, at the City Hall, in the City, at 5:30 o’clock p.m., at which time and place a hearing will be held and proceedings will be instituted and action taken to enter into the Agreement.

Section 2. The City Clerk is hereby directed to give notice of the proposed action on the Agreement setting forth the amount and purpose thereof, the time when and place where the said meeting will be held, by publication at least once, not less than four (4) and not more than twenty (20) days before the meeting, in a legal newspaper which has a general circulation in the City. The notice shall be in substantially the following form:

NOTICE OF PROPOSED ACTION TO INSTITUTE
PROCEEDINGS TO ENTER INTO A LOAN AND DISBURSEMENT AGREEMENT
IN A PRINCIPAL AMOUNT NOT TO EXCEED \$3,380,000

(SEWER REVENUE)

The City Council of the City of Muscatine, Iowa, will meet on February 17, 2026, at the City Hall, in the City, at 5:30 o'clock p.m., for the purpose of instituting proceedings and taking action to enter into a loan and disbursement agreement (the "Agreement") and to borrow money thereunder in a principal amount not to exceed \$3,380,000, for the purpose of paying the cost, to that extent, of planning, designing and constructing improvements and extensions to the Municipal Sanitary Sewer System (the "Utility") of the City.

The Agreement will not constitute a general obligation of the City, nor will it be payable in any manner by taxation but, together with the City's outstanding Sewer Revenue Bond, SRF Series 2008, dated November 5, 2008, and any additional obligations of the City as may be hereafter issued and outstanding from time to time ranking on a parity therewith, will be payable solely and only from the Net Revenues of the Utility.

At the aforementioned time and place, oral or written objections may be filed or made to the proposal to enter into the Agreement. After receiving objections, the City may determine to enter into the Agreement, in which case, the decision will be final unless appealed to the District Court within fifteen (15) days thereafter.

By order of the City Council of the City of Muscatine, Iowa.

Cinda Hilger
City Clerk

Section 3. Pursuant to Section 1.150-2 of the Income Tax Regulations (the “Regulations”) of the Internal Revenue Service, the City declares (a) that it intends to undertake the Project which is reasonably estimated to cost approximately \$3,380,000, (b) that other than (i) expenditures to be paid or reimbursed from sources other than the issuance of bonds, notes or other obligations (the “Bonds”), or (ii) expenditures made not earlier than 60 days prior to the date of this Resolution or a previous intent resolution of the City, or (iii) expenditures amounting to the lesser of \$100,000 or 5% of the proceeds of the Bonds, or (iv) expenditures constituting preliminary expenditures as defined in Section 1.150-2(f)(2) of the Regulations, no expenditures for the Project have heretofore been made by the City and no expenditures will be made by the City until after the date of this Resolution or a prior intent resolution of the City, and (c) that the City reasonably expects to reimburse the expenditures made for costs of the City out of the proceeds of the Bonds. This declaration is a declaration of official intent adopted pursuant to Section 1.150-2 of the Regulations.

Section 4. All resolutions or parts of resolutions in conflict herewith are hereby repealed to the extent of such conflict.

Section 5. This resolution shall be in full force and effect immediately upon its adoption and approval, as provided by law.

Passed and approved this February 3, 2026.

Mayor

Attest:

City Clerk

••••

On motion and vote, the meeting adjourned.

Mayor

Attest:

City Clerk

ATTESTATION CERTIFICATE:

STATE OF IOWA
MUSCATINE COUNTY
CITY OF MUSCATINE

SS:

I, the undersigned, City Clerk of the aforementioned City, do hereby certify that attached hereto is a true and correct copy of the proceedings of the City Council relating to fixing a date for hearing on the City Council's proposal to take action in connection with a Sewer Revenue Loan and Disbursement Agreement.

WITNESS MY HAND this ____ day of _____, 2026.

City Clerk

ORGANIZATION AND ESTABLISHMENT CERTIFICATE:

STATE OF IOWA
MUSCATINE COUNTY
CITY OF MUSCATINE

SS:

I, the undersigned City Clerk, do hereby certify that the aforementioned City is organized and operating under the provisions of Title IX of the Code of Iowa and not under any special charter and that such City is operating under the Special Charter form of government and that there is not pending or threatened any question or litigation whatsoever touching the incorporation of the City, the inclusion of any territory within its limits or the incumbency in office of any of the officials hereinafter named.

And I do further certify that the following named parties are officials of the City as indicated:

| | |
|-------|--------------------------------|
| _____ | Mayor |
| _____ | City Clerk |
| _____ | City Administrator |
| _____ | Finance Officer/City Treasurer |
| _____ | Council Member/Mayor Pro Tem |
| _____ | Council Member |
| _____ | Council Member |
| _____ | Council Member |
| _____ | Council Member |
| _____ | Council Member |
| _____ | Council Member |

I further certify that the City established the Municipal Sanitary Sewer System (the "Utility"), and that the Utility has been in continuous operation by the City since its establishment as aforesaid in supplying sanitary sewer service to the City and its inhabitants.

I further certify that the management and control of the Utility are vested in the City Council of the City, and that no board of trustees exists which has any part of the control and management of such Utility.

WITNESS MY HAND this ____ day of _____, 2026.

City Clerk

OUTSTANDING DEBT CERTIFICATE:

STATE OF IOWA
MUSCATINE COUNTY
CITY OF MUSCATINE

SS:

I, the undersigned, City Clerk of the City of Muscatine, Iowa (the "City"), do hereby certify that the City has no bonds or other obligations of any kind now outstanding which are secured by and payable from the revenues derived from the operation of the Municipal Sanitary Sewer System (the "Utility"), except as follows:

| <u>Date</u> | <u>Type</u> | <u>Principal Amount Outstanding</u> | <u>Maturity</u> |
|-------------|---------------|---|-----------------|
| 11-05-2008 | Sewer Revenue | 6,552,000 \$ _____ | 06-01-2032 |

(Attach here a separate sheet listing any other outstanding obligations of the City secured by and payable from the revenues of the Utility excluding the proposed issue, if any)

WITNESS MY HAND this ____ day of _____, 2026.

City Clerk

PUBLICATION CERTIFICATE:

(PLEASE NOTE: Please do not date and return this certificate until you have received the publisher’s affidavit and have verified that the notice was published on the date indicated in the affidavit, but please return all other completed pages to us as soon as they are available.)

STATE OF IOWA
MUSCATINE COUNTY
CITY OF MUSCATINE

SS:

I, the undersigned, City Clerk of the aforementioned City, do hereby certify that pursuant to the resolution of its City Council fixing a date of meeting at which it is proposed to take action to enter into a loan and disbursement agreement, the notice, of which the printed slip attached to the publisher’s affidavit hereto attached is a true and complete copy, was published on the date and in the newspaper specified in such affidavit, which newspaper has a general circulation in the City.

WITNESS MY HAND this ____ day of _____, 2026.

City Clerk

(Attach here the publisher’s original affidavit with clipping of the notice, as published.)



City of Muscatine

ITEM NUMBER 2026-0049

AGENDA ITEM SUMMARY

DATE: 2/3/2026

STAFF

Andrew Fangman, Assistant Community Development Director

SUBJECT

Resolution Approving Amended Development Agreement with Merge, LLC

EXECUTIVE SUMMARY

On September 5, 2024, the City Council approved a Development Agreement with Merge, LLC, to construct a mixed-use residential and commercial project at the southeast corner of Hershey Avenue and Green Street, known as Carver Corner. The initial phase features a five-story, 56-unit mixed-use building. Under this agreement, Merge, LLC will receive annual tax increment financing (TIF) rebates for up to 15 years following project completion, with a total aggregate payout not to exceed \$3,000,000. While the original agreement required the project to be completed by December 31, 2025, the developer encountered several delays. With construction now ready to commence, an amendment to the development agreement is necessary to reflect the updated project timeline.

STAFF RECOMMENDATION

Staff recommends approval of the resolution approving this Development Agreement.

BACKGROUND/DISCUSSION

This proposed amendment introduces the following substantial changes to the development agreement approved in 2024:

Construction Commencement: Merge agrees to make good faith efforts to begin construction on the project footings as soon as possible, but in any event, shall commence construction no later than December 31, 2026.

Project Completion: Merge agrees to complete the project no later than December 31, 2028.

Tax Rebate Timeline Adjustment: The time period for the City's incremental property tax rebates has been adjusted to align with the updated construction timeline.

Reversionary Clause: If construction on the project footings has not commenced by December 31, 2026, ownership of Lot 2 of the Carver Corner Subdivision shall revert back to the City.

CITY FINANCIAL IMPACT

This project will be funded from future incremental property taxes (TIF) funds, and as such, will have no impact on the current City budget

ATTACHMENTS

- 1. Approve Amend Dev Agmt (Merge) (Muscatine #73 2026)-v2
- 2. Amended Development Agreement (Merge) (Muscatine #73 2024)-v1

APPROVE AMENDED DEVELOPMENT AGREEMENT

(Merge, LLC)

421464-73

Muscatine, Iowa

February 3, 2026

A meeting of the City Council of the City of Muscatine, Iowa, was held at _____ p.m., on February 3, 2026, at the _____ in the City, pursuant to the rules of the Council.

The Mayor presided and the roll was called, showing members present and absent as follows:

Present: _____

Absent: _____.

Council Member _____ introduced the resolution next hereinafter set out and moved its adoption, seconded by Council Member _____; and after due consideration thereof by the Council, the Mayor put the question upon the adoption of said resolution, and the roll being called, the following named Council Members voted:

Ayes: _____

Nays: _____.

Whereupon, the Mayor declared said resolution duly adopted, as follows:

RESOLUTION 2026-0049

Resolution Approving Amended Development Agreement with Merge, LLC

WHEREAS, the City of Muscatine, Iowa (the “City”), pursuant to and in strict compliance with all laws applicable to the City, and in particular the provisions of Chapter 403 of the Code of Iowa, has adopted an Urban Renewal Plan for the Consolidated Muscatine Urban Renewal Area (the “Urban Renewal Area”); and

WHEREAS, this City Council has adopted an ordinance providing for the division of taxes levied on taxable property in the Urban Renewal Area pursuant to Section 403.19 of the Code of Iowa and establishing the fund referred to in Subsection 2 of Section 403.19 of the Code of Iowa (the “Urban Renewal Tax Revenue Fund”), which fund and the portion of taxes referred to in that subsection may be irrevocably pledged by the City for the payment of the principal of and interest on indebtedness incurred under the authority of Section 403.9 of the Code of Iowa to finance or refinance in whole or in part projects in the Urban Renewal Area; and

WHEREAS, the City has previously entered into a certain development agreement (the “Original Agreement”) with Merge, LLC (the “Developer”) pursuant to which the Developer agreed to undertake the development and construction of a five-story mixed-use building (the “Project”); and

WHEREAS, under the Original Agreement, the City agreed to provide financial assistance in the form of annual appropriation incremental property tax payments (the “Payments”) to the Developer in an amount not exceeding \$3,000,000; and

WHEREAS, the City and the Developer now propose to amend the Original Agreement in order to (i) adjust the completion date of the Project; (ii) adjust the time period during which the City will make incremental property tax payments to the Developer; and (iii) make other related changes; and

WHEREAS, an amended agreement (the “Amended Agreement”) has been prepared to set forth the new understanding between the City and the Developer with respect to the corrected base valuation date, and it is now necessary to make provision for its approval; and

WHEREAS, Chapter 15A of the Code of Iowa (“Chapter 15A”) declares that economic development is a public purpose for which a City may provide grants, loans, tax incentives, guarantees and other financial assistance to or for the benefit of private persons; and

WHEREAS, Chapter 15A requires that before public funds are used for grants, loans, tax incentives or other financial assistance, a City Council must determine that a public purpose will reasonably be accomplished by the spending or use of those funds; and

WHEREAS, Chapter 15A requires that in determining whether funds should be spent, a City Council must consider any or all of a series of factors;

NOW, THEREFORE, It Is Resolved by the City Council of the City of Muscatine, Iowa, as follows:

Section 1. Pursuant to the factors listed in Chapter 15A, the Council hereby reaffirms that:

(a) The Project will add diversity and generate new opportunities for the Muscatine and Iowa economies;

(b) The Project will generate public gains and benefits, particularly in the creation and retention of jobs and income and the creation of new housing opportunities, which are warranted in comparison to the amount of the proposed Payments.

Section 2. The City Council further finds and reaffirms that a public purpose will reasonably be accomplished by entering into the Amended Agreement and providing the Payments to the Developer.

Section 3. The Amended Agreement is hereby approved, and the Mayor and City Clerk are hereby authorized and directed to execute and deliver the Amended Agreement on behalf of the City, in substantially the form and content in which the Amended Agreement has been presented to this City Council. The Mayor, the Assistant Community Development Director, and the City Administrator are also authorized to make such changes, modifications, additions or deletions as they, with the advice of bond counsel, may believe to be necessary, and to take such actions as may be necessary to carry out the provisions of the Amended Agreement.

Section 4. All payments by the City under the Amended Agreement shall be subject to annual appropriation by the City Council, in the manner set out in the Amended Agreement. As provided and required by Chapter 403 of the Code of Iowa, the City's obligations under the Amended Agreement shall continue to be payable solely from a subfund (the "Merge, LLC (Apartment Building) Subfund") which was established by prior resolution of the Council, into which shall be paid that portion of the income and proceeds of the Urban Renewal Tax Revenue Fund attributable to property taxes derived from the property as described as follows:

Lot 2 of the Carver Corner Subdivision, First Addition, City of Muscatine, Muscatine County, Iowa.

Section 5. The City hereby reaffirms the pledge of the Merge, LLC Subfund and the taxes referred to in Subsection 2 of Section 403.19 of the Code of Iowa to be paid into such Subfund to the payment of the Agreement, provided, however, that no payment will be made under the Amended Agreement unless and until monies from the Merge, LLC Subfund are appropriated for such purpose by the City Council.

Section 6. All resolutions or parts thereof in conflict herewith are hereby repealed.

Passed and approved on February 3, 2026.

Mayor

Attest:

City Clerk

•••••

On motion and vote the meeting adjourned.

Mayor

Attest:

City Clerk

STATE OF IOWA
MUSCATINE COUNTY
CITY OF MUSCATINE

SS:

I, the undersigned, City Clerk of the aforementioned City, hereby certify that the foregoing is a true and correct copy of the minutes of the Council of the City relating to adopting a resolution to approve an amended development agreement with Merge, LLC.

WITNESS MY HAND hereto affixed this ____ day of _____, 2026.

City Clerk

AMENDED DEVELOPMENT AGREEMENT

This Amended Development Agreement is entered into between the City of Muscatine, Iowa (the “City”) and Merge, LLC (the “Company”) as of the 3rd day of February, 2026 (the “Commencement Date”).

WHEREAS, the City has established the Consolidated Muscatine Urban Renewal Area (the “Urban Renewal Area”) and has adopted a tax increment ordinance for the Urban Renewal Area; and

WHEREAS, the Company has proposed to acquire certain real property from the City, which is situated in the City, lies within the Urban Renewal Area and is more specifically described on Exhibit A hereto (the “Property”); and

WHEREAS, the Company has proposed to undertake the construction of a five-story mixed-use building (the “Project”) including commercial units (the “Commercial Units”) and residential units (the “Residential Units”); and

WHEREAS, the Company has requested that the City provide financial assistance in the form of incremental property tax payments to be used by the Company in paying the costs of constructing and maintaining the Project; and

WHEREAS, the City and the Company entered into a Development Agreement (the “Original Agreement”) dated September 5, 2024, pursuant to which the Company agreed to undertake the Project on the Property, and the City agreed to provide incremental property tax payments to the Company to assist the Company in paying the costs of the Project; and

WHEREAS, it is now necessary to amend the Original Agreement to (i) adjust the completion date of the Project; (ii) adjust the time period during which the City will make incremental property tax payments to the Company; and (iii) make other related changes; and

WHEREAS, this Amended Development Agreement (the “Agreement”) has been prepared to set forth the updated, mutual understanding between the City and the Company and to replace the Original Agreement; and

WHEREAS, Chapter 15A of the Code of Iowa authorizes cities to provide grants, loans, guarantees, tax incentives and other financial assistance to or for the benefit of private persons;

NOW THEREFORE, the parties hereto agree as follows:

A. Company's Covenants

1. Property Acquisition; Project Construction; Operational Requirement

Property Acquisition

The Company agrees to acquire the Property from the City at a purchase price of \$50,000 (the "Purchase Price") by June 1, 2026. The real estate transaction for the conveyance of the Property will be documented and conducted through separate purchase agreements, deeds of sale and related documents ("Real Estate Documents") as agreed to by the City and the Company, and such Real Estate Documents must be properly recorded by June 1, 2026.

The Company acknowledges that in lieu of advancing the Purchase Price to the City on the date of the closing of the real estate transaction that the City will withhold an amount (the "Purchase Price Withholding Amount") equal to the Purchase Price from the Incremental Property Tax Revenues (as hereinafter defined) received by the City to make the Payments (as hereinafter defined) before making any Payments to the Company in order to collect the Purchase Price from the Company.

Project Construction

The Company agrees to construct the Project on the Property. The Company agrees to make good faith efforts to commence construction of the footings for the Project as soon as practicable after the Commencement Date of this Agreement, but in any event shall commence such construction by no later than December 31, 2026.

Furthermore, the Company expects this construction to result in approximately \$6,000,000 in capital improvements for the Property, including construction work, equipment, furnishings and other capital improvements. The Project shall minimally include a five-story, fifty-six-unit mixed-use building with a mix of studio, one bedroom and two bedroom Residential Units; residential lobby space, bike storage and approximately 4,500 square feet of Commercial Units on the ground floor; the installation of at least one (1) electric vehicle charging station on the Property; and the installation of a designated pet relief area and pet waste stations on the Property.

The Company agrees to submit a detailed site plan (the "Site Plan") for the development of the Project to the City in accordance with City Code Section 10-2-7(I). Upon approval by the City of the Site Plan it shall be attached hereto as Exhibit B. The Site Plan shall include a plan for stormwater management for the Property that demonstrates compliance with SUDAS Section 2G-1.B.3. as well as the Extreme Flood Protection Criteria from the Iowa Storm Water Management Manual. The Site Plan may be amended in accordance with the Muscatine City Code by mutual written consent of the parties.

The Company agrees to construct the Project in accordance with the Site Plan and all local zoning, land use, building and safety codes and regulations. The Company agrees to complete construction of the Project by no later than December 31, 2028.

Maintenance and Use of the Project and the Property

The Company agrees to maintain ownership of the Project and to use the completed Project as part of its business operations on the Property throughout the Term (as hereinafter defined) of this Agreement (the “Operational Requirement”). For purposes of this Agreement, the Project is being used as part of the Company’s business operations if (a) the Commercial Units are being used as part of the ongoing business operations of one more commercial enterprise(s) or the Commercial Units are actively available for lease in the ongoing business operations of one or more commercial enterprise(s) at a reasonable market rate; and (b) the Residential Units are occupied or are being offered for occupancy at a reasonable market rate.

The Company further agrees to maintain, preserve, and keep the Property, including but not limited to the Project, useful and in good repair and working order, ordinary wear and tear excepted, and from time to time will make all necessary repairs, replacements, renewals, and additions. Further, the Company agrees to maintain compliance with local zoning, land use, building and safety codes and regulations.

Further, the Company agrees to obtain and continuously maintain adequate insurance covering the Property, including the Project. The Company agrees to notify the City promptly in the case of damage exceeding \$250,000 in amount to, or destruction of, the Project resulting from fire or other casualty.

2. Company’s Operational Certifications. The Company agrees to certify (the “Operational Certification”) to the City by no later than October 15 of each year during the Term, commencing October 15, 2029, that the Company is in compliance with the Operational Requirement. Each Operational Certification shall be accompanied by documentation demonstrating, to the satisfaction of the City, that the Company is in compliance with the Operational Requirement.

3. Property Taxes. The Company agrees to make timely payment of all property taxes as they come due with respect to the Property with the completed Project thereon and to submit a receipt or cancelled check in evidence of each such payment.

4. Property Tax Payment Certification. The Company agrees to certify to the City by no later than October 15th of each year during the Term, commencing on October 15, 2029, an amount (the “Company’s Estimate”) equal to 100% (the “Annual Percentage”) of the estimated Incremental Property Revenues, as hereinafter defined, anticipated to be paid in the fiscal year immediately following such certification with respect to the taxable valuation of the Property. The Company will submit the Company’s Estimate by completing and submitting the worksheet attached hereto as Exhibit C. The City reserves the right to review and request revisions to each such Company’s Estimate to ensure the accuracy of the figures submitted.

For purposes of this Agreement, Incremental Property Tax Revenues are calculated by: (1) determining the consolidated property tax levy (city, county, school, etc.) then in effect with respect to taxation of the Property; (2) subtracting (a) the debt service levies of all taxing jurisdictions, (b) the school district instructional support and physical plant and equipment levies and (c) any other levies which may be exempted from such calculation by action of the Iowa

General Assembly; (3) multiplying the resulting modified consolidated levy rate times any incremental growth in the taxable (post-roll back) valuation of the Property, as shown on the property tax rolls of Muscatine County, above and beyond the Base Valuation; and (4) deducting any State of Iowa property tax credits which may from time to time be claimed with respect to the Property.

The “Base Valuation” of the Property for purposes of calculating Incremental Property Tax Revenues under this Agreement and Section 403.19 of the Code of Iowa shall be the taxable valuation of the Property as of January 1, 2024.

Upon request, the City staff shall provide reasonable assistance to the Company in completing the worksheet required under this Section A.4.

5. Reversionary Interest. Notwithstanding any other provision of this Agreement, the conveyance of the Property shall be made subject to the express condition that the Company shall commence construction of the footings for the Project by December 31, 2026.

If said condition as to all or any part of the Project is not met, then, at the City’s option, exercisable by written notice to Company at any time following the conveyance and failure to meet any of the requirements, which notice sets forth the nature of the breach or violation and further provided that if the breach or violation is not corrected to City’s reasonable satisfaction within thirty (30) days of the date of receipt of the notice, then all right, title and interest in and to the portion of the Property and to any improvements thereon, together with the right of immediate possession thereof, will revert to and revest in the City and City’s assigns, as fully and completely as if the deed conveying the Property to the Company had not been executed. Written notice shall be by first class U.S. Mail, postage prepaid, to the Company, at the address set forth below, and shall be deemed received after three (3) days after being deposited in the mail.

This reversion shall be more specifically documented under separate real estate purchase agreements, deeds and such other documentation as shall be deemed necessary by the City and shall survive the termination of this Agreement.

6. Legal and Administrative Costs. The Company hereby agrees to pay for the legal fees and administrative costs incurred by the City in connection with the drafting, negotiation and authorization of the Original Agreement and this Agreement, including the prerequisite amendment to the urban renewal plan, up to an amount not in excess of \$10,000. The Company agrees to remit payment to the City within 30-days of the submission of reasonable documentation by the City to the Company evidencing such costs.

7. Default Provisions.

a. Events of Default. The following shall be “Events of Default” under this Agreement, and the term “Event of Default” shall mean, whenever it is used in this Agreement (unless otherwise provided), any one or more of the following events:

- (i) Failure by the Company to commence construction of the footings for the Project, pursuant to the terms and conditions of this Agreement.
- (ii) Failure by the Company to complete construction of the Project, pursuant to the terms and conditions of this Agreement.
- (iii) Failure by the Company to fully and timely remit payment of property taxes when due and owing.
- (iv) Failure by the Company to comply with Section A.2, A.4, A.5 and A.6 of this Agreement.
- (v) Failure by the Company to observe or perform any other material covenant on its part, to be observed or performed hereunder.

b. Notice and Remedies. Whenever any Event of Default described in this Agreement occurs, the City shall provide written notice to the Company describing the cause of the default and the steps that must be taken by the Company in order to cure the default. The Company shall have thirty (30) days after receipt of the notice to cure the default or to provide assurances satisfactory to City that the default will be cured as soon as reasonably possible. If the Company fails to cure the default or provide assurances, the City shall then have the right to:

- (i) Pursue any action available to it, at law or in equity, in order to enforce the terms of this Agreement.
- (ii) Withhold the Payments provided for under Section B.1 below.

B. City's Obligations

1. Payments. In recognition of the Company's obligations set out above, the City agrees to make thirty (30) semiannual economic development tax increment payments (the "Payments" and each, individually a "Payment") to the Company during the Term, pursuant to Chapters 15A and 403 of the Code of Iowa, provided however that the aggregate, total amount of the Payments (the "Maximum Payment Total") shall not exceed \$3,000,000. All Payments under this Agreement shall be subject to annual appropriation by the City Council, as provided hereunder.

The Payments shall not constitute general obligations of the City, but shall be made solely and only from the Annual Percentage of Incremental Property Tax Revenues received by the City from the Muscatine County Treasurer attributable to the taxable valuation of the Property.

Prior to funding any Payments under this Agreement, the City will first withhold from the Incremental Property Tax Revenues an amount equal to the Purchase Price Withholding Amount. Once an amount equal to the Purchase Price Withholding Amount has been withheld by the City, the Payments shall be made as set forth herein.

This Agreement assumes that the full taxable valuation resulting from the Project will go on the property tax rolls as of January 1, 2029. Accordingly, assuming all appropriation determinations are approved affirmatively by the City Council under Section B.2 below, Payments will be made on December 1 and June 1 of each fiscal year, beginning December 1,

2030, and continuing through and including June 1, 2045, or until such earlier date upon which total Payments equal to the Maximum Payment Total have been made.

2. Annual Appropriation. The Payments shall be subject to annual appropriation by the City Council. Prior to December 1 of each year during the Term of this Agreement, commencing in calendar year 2029, the City Council of the City shall consider the question of obligating for appropriation to the funding of the Payments due in the following fiscal year, an amount (the “Appropriated Amount”) of Incremental Property Tax Revenues to be collected in the following fiscal year equal to or less than the most recently submitted Company’s Estimate.

In any given fiscal year, if the City Council determines to not obligate the then-considered Appropriated Amount, then the City will be under no obligation to fund the Payments scheduled to become due in the following fiscal year, and the Company will have no rights whatsoever to compel the City to make such Payments, to seek damages relative thereto or to compel the funding of such Payments in future fiscal years. A determination by the City Council to not obligate funds for any particular fiscal year’s Payments shall not render this Agreement null and void, and the Company shall make the next succeeding submission of the Company’s Estimate as called for in Section A.4 above, provided however that no Payment shall be made after June 1, 2045.

3. Payment Amounts. The aggregate Payments to be made in a fiscal year shall not exceed an amount equal to the corresponding Appropriated Amount (for example, for the Payments due on December 1, 2030 and on June 1, 2031, the aggregate maximum amount of such Payments would be determined by the Appropriated Amount determined for certification by December 1, 2029). Furthermore, the amount of each such Payment shall not exceed the Annual Percentage of Incremental Property Tax Revenues (excluding allocations of “back-fill” or “make-up” payments from the State of Iowa for property tax credits or roll-back) actually received by the City from the Muscatine County Treasurer attributable to the taxable incremental valuation of the Property in the six (6) months immediately preceding such Payment due date.

4. Certification of Payment Obligation. In any given fiscal year, if the City Council determines to obligate the then-considered Appropriated Amount, as set forth in Section B.2 above, then the City Clerk will certify by December 1 of each such year to the Muscatine County Auditor an amount equal to the most recently obligated Appropriated Amount.

C. Administrative Provisions

1. Amendment and Assignment. The parties hereto may not cause this Agreement to be amended, assigned, assumed, sold or otherwise transferred without the prior written consent of the other party. However, the City hereby gives its permission that the Company’s rights to receive the Payments hereunder may be assigned by the Company to a private lender, as security on a credit facility taken with respect to the Project, without further action on the part of the City.

2. Successors. This Agreement shall inure to the benefit of and be binding upon the successors and assigns of the parties.

3. **Term.** The term (the “Term”) of this Agreement shall commence on the Commencement Date and end on June 1, 2045 or on such earlier date upon which the aggregate sum of Payments made to the Company equals the Maximum Payment Total.

4. **Choice of Law.** This Agreement shall be deemed to be a contract made under the laws of the State of Iowa and for all purposes shall be governed by and construed in accordance with laws of the State of Iowa.

The City and the Company have caused this Agreement to be signed, in their names and on their behalf by their duly authorized officers, all as of the day and date written above.

CITY OF MUSCATINE, IOWA

By: _____
Mayor, Brad Bark

Attest:

City Clerk, Cinda Hilger

MERGE, LLC

By: _____

EXHIBIT A
DESCRIPTION OF THE PROPERTY

Lot 2 of the Carver Corner Subdivision, First Addition, City of Muscatine,
Muscatine County, State of Iowa

EXHIBIT B
SITE PLAN

[ATTACH SITE PLAN HERE]

EXHIBIT C
COMPANY'S ESTIMATE WORKSHEET

- (1) Date of Preparation: October _____, 20____.
- (2) Assessed Taxable Valuation of Property as of January 1, 20____:
\$_____.
- (3) Base Taxable Valuation of Property:
\$_____.
- (4) Incremental Taxable Valuation of Property (2 minus 3):
\$_____ (the "TIF Value").
- (5) Current City fiscal year consolidated property tax levy rate for purposes of calculating Incremental Property Tax Revenues (the "Adjusted Levy Rate"):
\$_____ per thousand of value.
- (6) The TIF Value (4) factored by the Adjusted Levy Rate (5).
\$_____ x \$_____/1000 = \$_____ (the "TIF Estimate")
- (7) Subtract anticipated property tax credits from the TIF Estimate (6 minus 7) =
\$_____ (the "Company's Estimate")



City of Muscatine

ITEM NUMBER 2026-0050

AGENDA ITEM SUMMARY

DATE: 2/3/2026

STAFF

Matthew Mardesen, City Administrator

SUBJECT

Resolution Expressing Intent to Provide Financial Support to Kraft Heinz Foods Company

EXECUTIVE SUMMARY

Kraft Heinz Foods Company in the City of Muscatine has proposed to undertake the improvement of its existing manufacturing facilities on certain real property situated in the City of Muscatine, Iowa. Kraft Heinz Foods Company intends to make application to the Iowa

Economic Development Authority for financial assistance for this project through the High Quality Jobs Program (the "IEDA HQJ Program") under Part 13 of Chapter 15 of the Code of Iowa (the "Code"), and such program requires a certain level of local government support for the applicant's Expansion (the "Local Contribution Requirement"). With this Resolution, the City intends to provide the Local Contribution Requirement to the Company for the project through the provision of property tax exemption on a portion of the actual value added by this project

for a period of ten years (the "Tax Exemption Benefit") under Chapter 404 of the Code of Iowa to help the Company to defray the costs of the project and to satisfy the Local Contribution Requirement.

STAFF RECOMMENDATION

Staff recommends approval of this Resolution.

BACKGROUND/DISCUSSION

City staff have been working with representatives of Kraft Heinz Foods Company to determine the form of

local government support. With this Resolution, the City intends to provide the Local Contribution Requirement to the Company for the project through the provision of property tax exemption on on a portion of the actual added by the project for a period of ten years (the "Tax Exemption Benefit") under Chapter 404 of the Code of Iowa to help the Company to defray the costs of the project and to satisfy the Local Contribution Requirement.

Chapter 404 - 10-year sliding scale breakdown. The amount of the partial exemption is equal to a percent of the actual value added by the improvements, determined as follows: a. For the first year, eighty percent. b. For the second year, seventy percent. c. For the third year, sixty percent. d. For the fourth year, fifty percent. e. For the fifth year, forty percent. f. For the sixth year, forty percent. g. For the seventh year, thirty percent. h. For the eighth year, thirty percent. i. For the ninth year, twenty percent. j. For the tenth year, twenty percent.

CITY FINANCIAL IMPACT

Since the City's financial assistance will be based on the incremental value of this project, this project will not have a financial impact to the City's current operation.

ATTACHMENTS

- 1. kraft

MINUTES TO ADOPT RESOLUTION
EXPRESSING INTENT TO PROVIDE
FINANCIAL SUPPORT

421464-79

Muscatine, Iowa

February 3, 2026

A meeting of the City Council of the City of Muscatine, Iowa, was held at __:____ p.m., on February 3, 2026, pursuant to the rules of the Council. The Mayor presided and the roll being called, the following members of the Council were present and absent:

Present: _____

Absent: _____.

The Mayor presided and the roll was called, showing members present and absent as follows:

Present: _____

Absent: _____.

Council Member _____ moved the adoption of the following resolution entitled "Resolution expressing intent to provide financial support to Kraft Heinz Foods Company," and the motion was seconded by Council Member _____. Following due consideration, the Mayor put the question on the motion and the roll being called, the following named Council Members voted:

Ayes: _____

Nays: _____.

Whereupon, the Mayor declared the resolution duly adopted as follows:

RESOLUTION NO. 2026-0050

Resolution expressing intent to provide financial support to Kraft Heinz Foods Company

WHEREAS, Kraft Heinz Foods Company (the “Company”) has proposed to undertake the improvement of its existing manufacturing facilities (the “Project”) on certain real property (the “Property”) situated in the City of Muscatine, Iowa (the “City”); and

WHEREAS, the Company has made application to the Iowa Economic Development Authority for financial assistance for the Project through the High Quality Jobs Program (the “IEDA HQJ Program”); and

WHEREAS, the City intends to provide local support to the Company for the Project through the City’s tax exemption program established pursuant to the Chapter 404 of the Code of Iowa;

NOW, THEREFORE, Be It Resolved by the City Council of the City of Muscatine, Iowa, as follows:

Section 1. The City hereby expresses its intent to provide financial support to the Company through the provision of property tax exemption on a portion of the actual value added by the Project for a period of ten years (the “Tax Exemption Benefit”) under Chapter 404 of the Code of Iowa to help the Company to defray the costs of the Project.

Section 2. The City hereby agrees to use its best efforts to complete the statutory requirements of the Chapter 404 of the Code of Iowa to implement the Tax Exemption Benefit. Both the City and the Company acknowledge that the City’s commitment in this Section is merely a present statement of intent and that the City Council must exercise its ordinary political discretion in the completion of the statutory processes referenced herein. The City will not be held liable in the event that the City Council, through the exercising of its ordinary political discretion, determines to not approve any of the actions outlined herein.

Section 3. All resolutions and orders or parts thereof in conflict with the provisions of this resolution, to the extent of such conflict, are hereby repealed.

Passed and approved this February 3, 2026.

Mayor

Attest:

City Clerk

• • • • •

On motion and vote the meeting adjourned.

Mayor

Attest:

City Clerk

STATE OF IOWA
MUSCATINE COUNTY
CITY OF MUSCATINE

SS:

I, the undersigned, City Clerk of the aforementioned City, do hereby certify that as such I have in my possession or have access to the complete corporate records of the City and of its officers; and that I have carefully compared the transcript hereto attached with the aforesaid records and that the attached is a true, correct and complete copy of the corporate records relating to the action taken by the City Council preliminary to and in connection with adopting a resolution expressing intent to provide a tax exemption benefit to Kraft Heinz Foods Company.

WITNESS my hand this ___ day of _____, 2026.

City Clerk



City of Muscatine

ITEM NUMBER 2026-0051

AGENDA ITEM SUMMARY

DATE: 2/3/2026

STAFF

Jon Koch, Water Pollution Control Plant Director

SUBJECT

Resolution Accepting Completed Work by Keokuk Construction, Inc, for the Houser Lift Station Renovation Project and Authorizing Final Payment in the Amount of \$10,030.15.

EXECUTIVE SUMMARY

Resolution Approving Completed Work by Keokuk Construction on the Houser Lift Station Renovation Project and authorizing final payment. The engineer has certified that the work performed is in substantial accordance with the plans and specifications and that the final amount of the contract is \$247,549.00.

STAFF RECOMMENDATION

Staff recommends approving the resolution.

BACKGROUND/DISCUSSION

The Houser Street Lift Station Renovation Project with Keokuk Construction, Inc. was approved by Council May 15th, 2025 and construction started in July of 2025. This replaced the two pumps, installed electrical components and installed a generator hookup to run the station during power outages. The contractor met the deadline and the engineer has certified that the work performed is acceptable. The original contract price was \$247,549.00 and there were no change orders.

CITY FINANCIAL IMPACT

This was budgeted to be taken from the Plant Replacement Reserve and came in \$59,634 under the engineers estimate.

ATTACHMENTS

1. NoticeOfAcceptability_HouserLS.260114
2. Resolution for Closeout Houser Reno.260128

NOTICE OF ACCEPTABILITY OF WORK

Owner: City of Muscatine Owner’s Project No.:
Engineer: Watersmith Engineering Engineer’s Project No.: 130.02
Contractor: Keokuk Contractors, Inc. Contractor’s Project No.:
Project: Houser Lift Station Mechanical Upgrade Project
Contract Name: Houser Lift Station Mechanical Upgrade Project
Notice Date: 1/14/2026 Effective Date of the Construction Contract: 5/22/2025

The Engineer hereby gives notice to the Owner and Contractor that Engineer recommends final payment to Contractor, and that the Work furnished and performed by Contractor under the Construction Contract is acceptable, expressly subject to the provisions of the Construction Contract’s Contract Documents (“Contract Documents. This Notice of Acceptability of Work (Notice) is made expressly subject to the following terms and conditions to which all who receive and rely on said Notice agree:

1. This Notice has been prepared with the skill and care ordinarily used by members of the engineering profession practicing under similar conditions at the same time and in the same locality.
2. This Notice reflects and is an expression of the Engineer’s professional opinion.
3. This Notice has been prepared to the best of Engineer’s knowledge, information, and belief as of the Notice Date.
4. This Notice is based entirely on and expressly limited by the scope of services Engineer has been employed by Owner to perform or furnish during construction of the Project (including observation of the Contractor’s Work) under the Owner-Engineer Agreement, and applies only to facts that are within Engineer’s knowledge or could reasonably have been ascertained by Engineer as a result of carrying out the responsibilities specifically assigned to Engineer under such Owner-Engineer Agreement.
5. This Notice is not a guarantee or warranty of Contractor’s performance under the Construction Contract, an acceptance of Work that is not in accordance with the Contract Documents, including but not limited to defective Work discovered after final inspection, nor an assumption of responsibility for any failure of Contractor to furnish and perform the Work thereunder in accordance with the Contract Documents, or to otherwise comply with the Contract Documents or the terms of any special guarantees specified therein.
6. This Notice does not relieve Contractor of any surviving obligations under the Construction Contract, and is subject to Owner’s reservations of rights with respect to completion and final payment.

Engineer

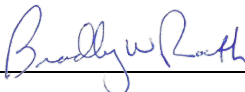
By (signature): 
Name (printed): Bradley W. Roeth
Title: Senior Engineer

RESOLUTION NO. 2026-0051

**RESOLUTION ACCEPTING COMPLETED WORK PERFORMED UNDER
THE HOUSER LIFT STATION RENOVATION PROJECT
AND AUTHORIZING FINAL PAYMENT**

WHEREAS, the City of Muscatine approved the Plans, Specifications, and Form of Contract for the Houser Lift Station Renovation Project; and

WHEREAS, the City of Muscatine entered into a contract for said project with Keokuk Contractors, Inc. with a contract amount of \$247,549.00; and

WHEREAS, all work under the contract has been completed by Keokuk Contractors, Inc. and approved and accepted by the Water Pollution Control Plant Director and appears to meet the requirements of the Plans and Specifications heretofore adopted by this Council; and

WHEREAS, the amount of \$237,518.85 has been previously paid to General Constructors, Inc. and a balance of \$10,030.15 for the project retainage remains due and payable;

NOW THEREFORE, BE IT RESOLVED BY THE CITY COUNCIL OF THE CITY OF MUSCATINE, IOWA, that the City of Muscatine accept the completed work under the Houser Lift Station Renovation Project and thereafter make a payment of \$10,030.15 which represents the remaining retainage thirty (30) days from the date of this acceptance.

PASSED, APPROVED, AND ADOPTED THIS 3RD DAY OF FEBRUARY, 2026.

CITY COUNCIL OF THE CITY OF MUSCATINE, IOWA

BY: _____
Bradley Bark, Mayor

ATTEST:

Matt Mardesen, City Administrator



City of Muscatine

ITEM NUMBER 2026-0034

AGENDA ITEM SUMMARY

DATE: 2/3/2026

STAFF

Matthew Mardesen, City Administrator

SUBJECT

Request to Approve the Issuance of a Purchase Order to Pearl City Hardwoods for the Purchase of a Customer Counter in the Finance Department

EXECUTIVE SUMMARY

Presented for City Council's consideration is a request to approve a purchase order to Peal City Hardwoods for the purchase of a new customer counter for the finance department.

STAFF RECOMMENDATION

Staff recommends approval of this request.

BACKGROUND/DISCUSSION

During the finance office remodel, the existing counter was removed due to the age and unsafe nature of the design. Over the past several months, the finance department has been working through a temporary bank teller window, causing customer concerns regarding privacy. The customers have complained that standing in the hallway to handle personal business is not acceptable. Two local vendors were contacted to design a new counter based on customer and finance department needs. Pearl City Hardwood was the only vendor that was able to customize the counter to meet the needs of customers as well as staff. This counter will provide the needed privacy and ADA requirements for customers and safety concerns for the staff.

CITY FINANCIAL IMPACT

There are funds available in the deferred maintenance line item to cover this purchase.

ATTACHMENTS

1. City Hall_Finance Desk_Estimate_010726
2. City Hall_Finance_Drawings_010726
3. City of Muscatine - Finance Office 072225



1103 Musser St.
Muscatine, IA 52761
563-260-6082

ESTIMATE

E25-2552

Date: 1/7/2026
Customer: City of Muscatine
Project: Finance Reception Desk
Material: oak

| Qty: | Product Description: | Amount: |
|------|--|--------------|
| 1 | Cabinetry per layout (1/7/26) <i>*includes 1/4 clear, tempered glass*</i> | \$ 10,612.15 |
| 1 | Quartz Countertops - Group A per layout (1/7/26) | \$ 2,517.84 |
| 1 | Color match oak - budgetary | \$ 350.00 |
| 1 | Installation & Materials for supports/wall/quartz desk | \$ 4,200.00 |

| | | |
|-----------------------|----|--------------------|
| Total Materials | \$ | 17,679.99 |
| Sales Tax | | |
| Estimate total | | \$17,679.99 |

Please note a 3.5% Fee will be added for all Credit Card Transactions

| | |
|--|------------|
| 50% deposit is required at time of order | \$8,840.00 |
| 50% Payment at time of delivery | \$8,840.00 |

This Proposal is valid for 30 days and subject to Pearl City Wood Products Terms and Conditions

Upon written acceptance by both parties, this Estimate constitutes a legal contract

Please return a signed copy of this document with your Purchase Order

Estimate accepted for: City of Muscatine

By: _____ Date: _____

Thank you for letting PCWP bid your project

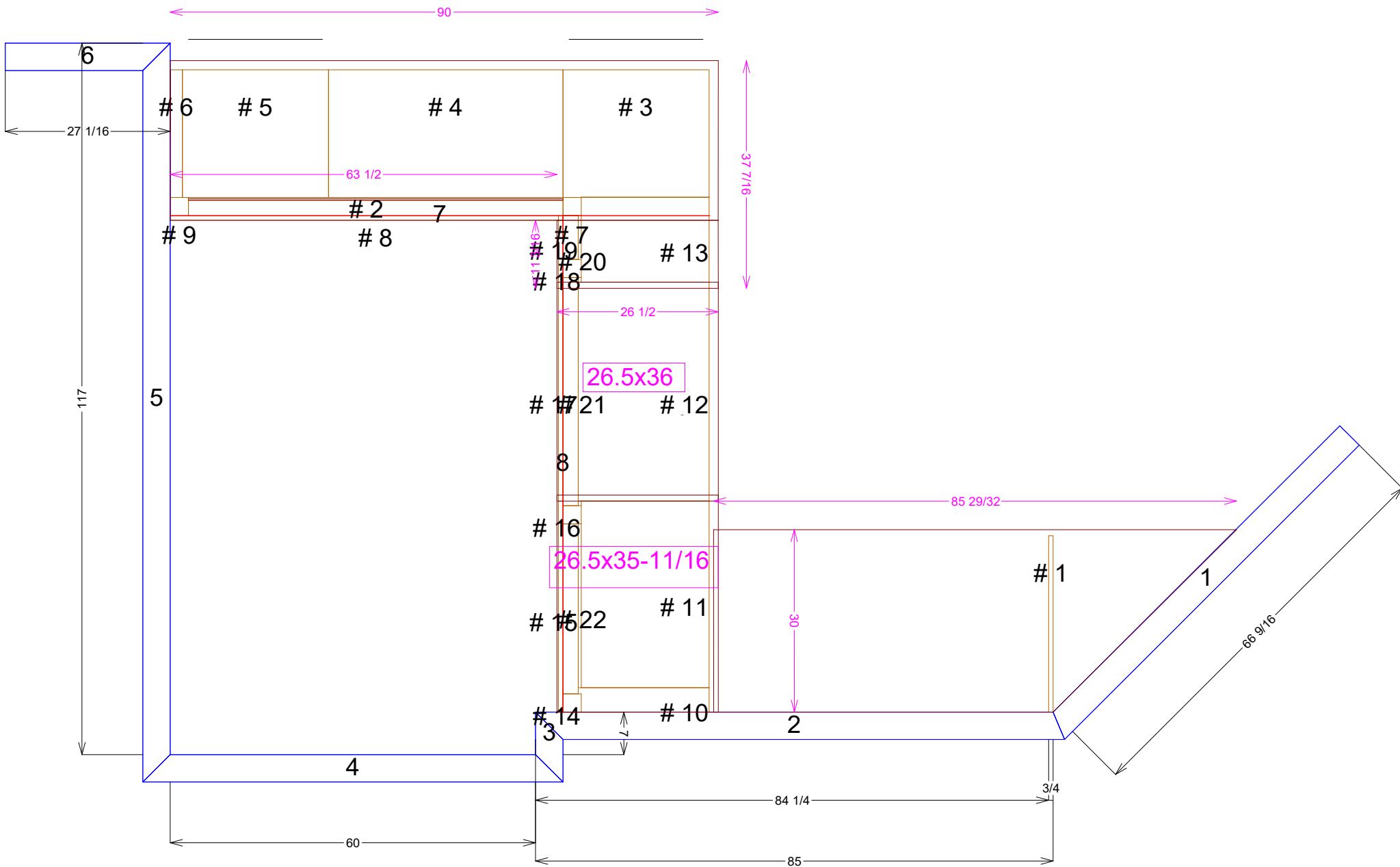

1103 Musser St.
Muscatine, IA 52761
(563) 260-6082

www.pearlcitywoodproducts.com

- Approved
- Rejected (as noted)

| | | | |
|--------------|--------------|------------------------|----------|
| Prepared for | Finance Desk | Plan View | |
| Project | City Hall | Scale 1 : 21.595842 | 01/07/26 |
| Job # | E25-2552 | A - 1 Sheet 1 of 4 | |

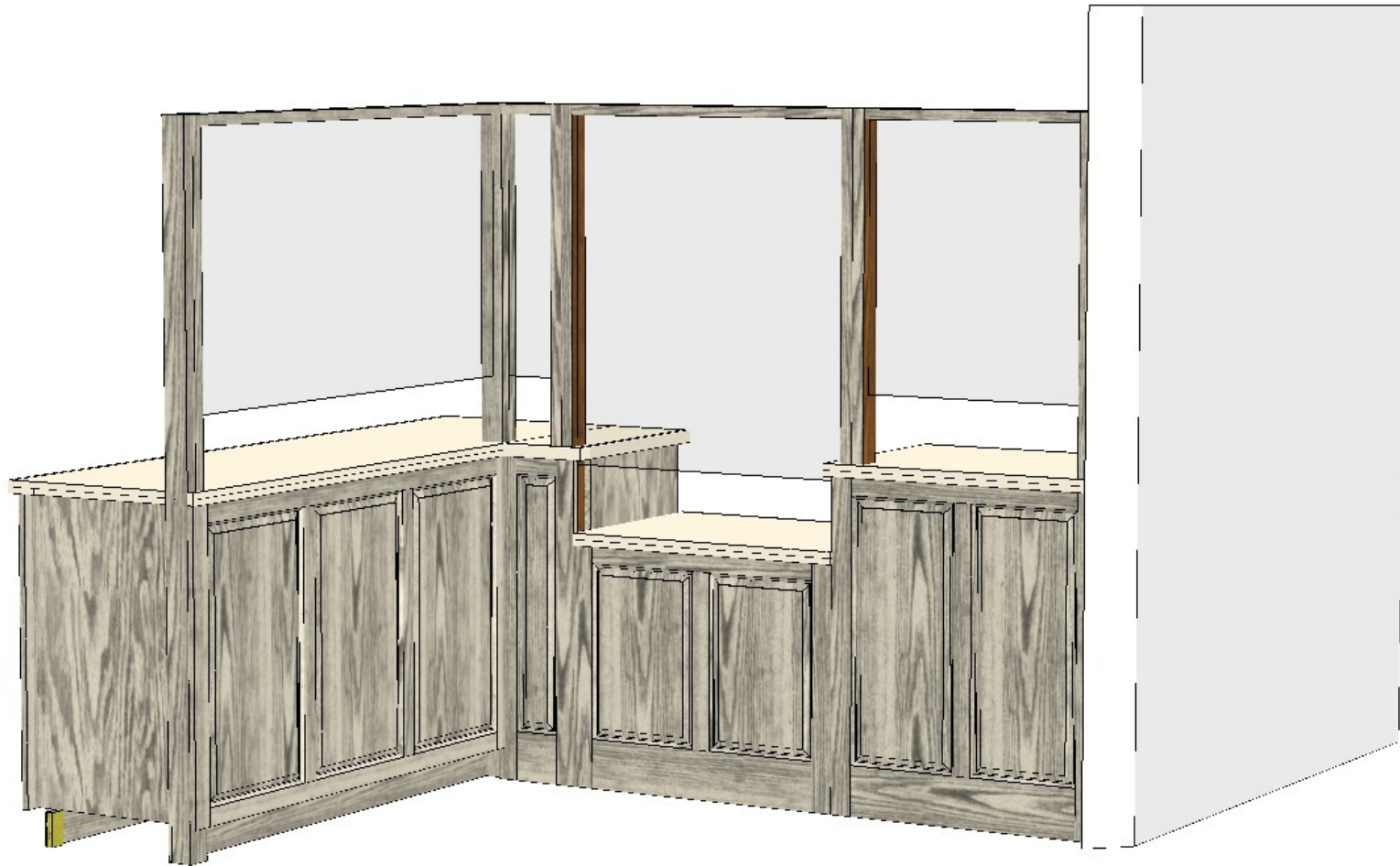

1103 Musser St.
Muscatine, IA 52761
(563) 260-6082

www.pearlcitywoodproducts.com

- Approved
- Rejected (as noted)

| | | | |
|--------------|--------------|--------------------------------------|----------|
| Prepared for | Finance Desk | 3D Public | |
| Project | City Hall | Scale 1 : 9.021024 | 01/07/26 |
| Job # | E25-2552 | A - 1 <small>Sheet 2 of 4</small> | |

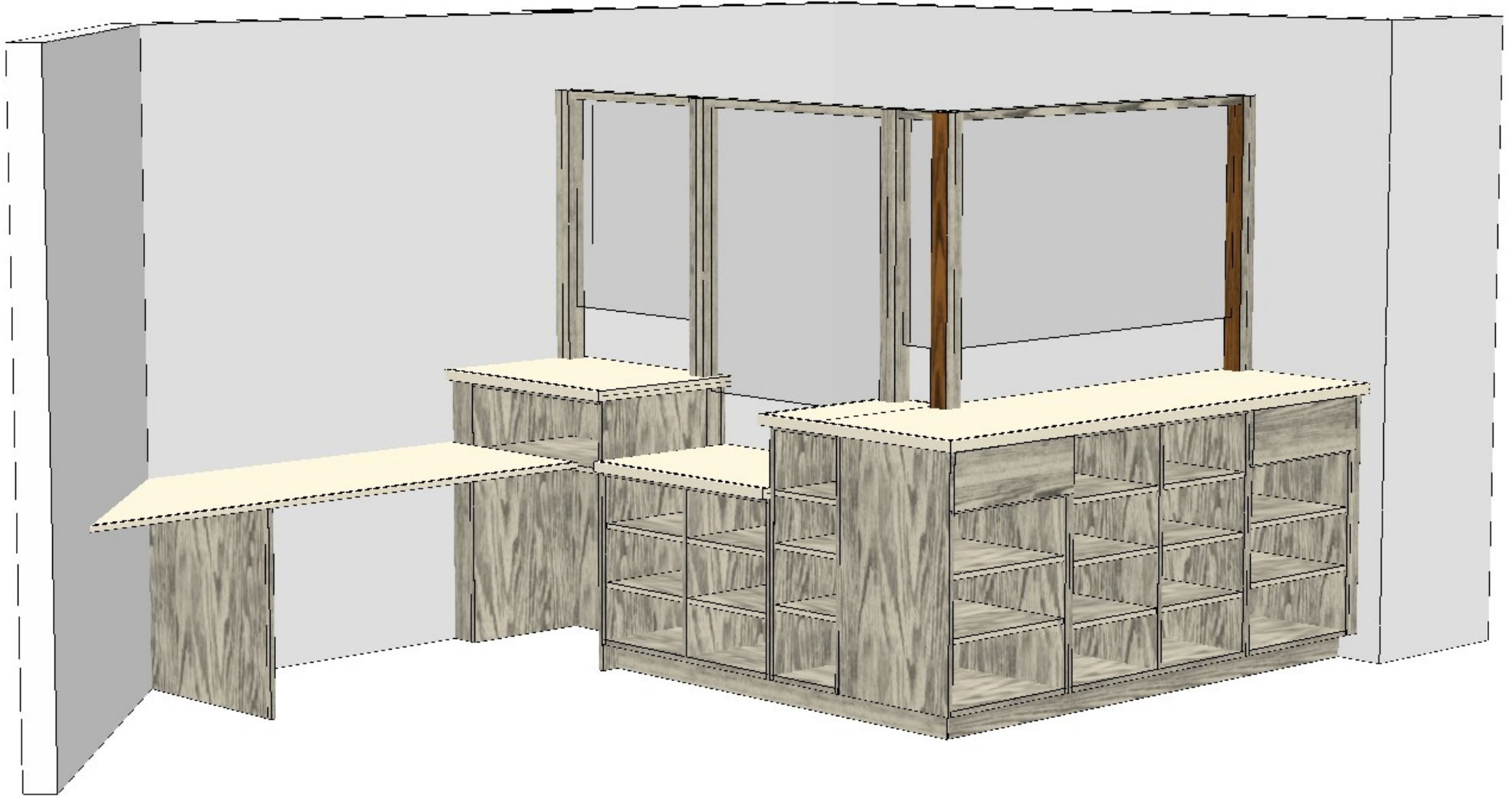

1103 Musser St.
Muscatine, IA 52761
(563) 260-6082

www.pearlcitywoodproducts.com

- Approved
- Rejected (as noted)

| | | | |
|--------------|--------------|--------------------------------------|----------|
| Prepared for | Finance Desk | 3D Staff | |
| Project | City Hall | Scale 1 : 8.357124 | 01/07/26 |
| Job # | E25-2552 | A - 1 <small>Sheet 3 of 4</small> | |

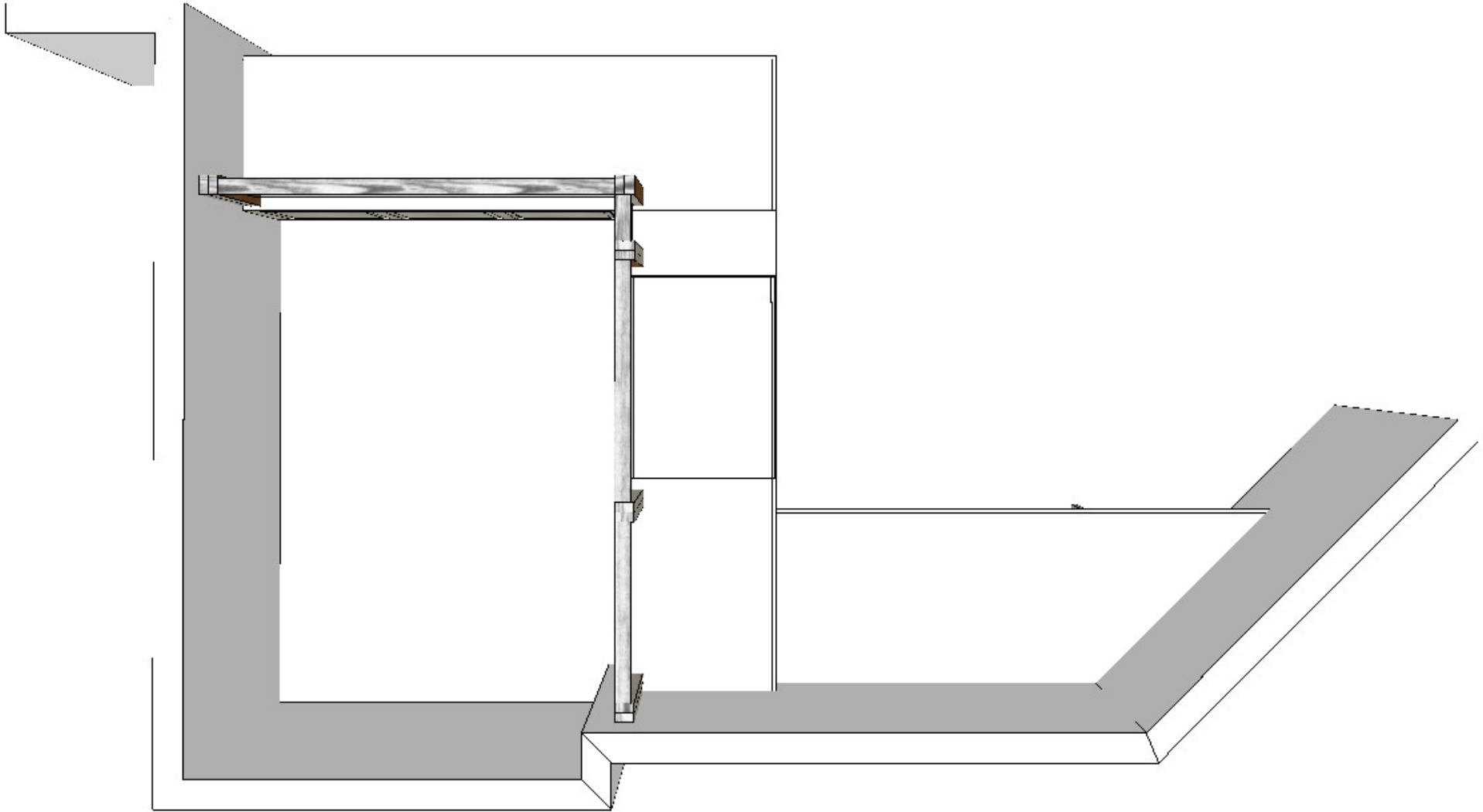

1103 Musser St.
Muscatine, IA 52761
(563) 260-6082

www.pearlcitywoodproducts.com

- Approved
- Rejected (as noted)

| | | | |
|--------------|--------------|--------------------------------------|----------|
| Prepared for | Finance Desk | 3D - Birdseye | |
| Project | City Hall | Scale 1 : 10.839513 | 01/07/26 |
| Job # | E25-2552 | A - 1 <small>Sheet 4 of 4</small> | |

CITY OF MUSCATINE

Who We
Are



OUR TEAM

OUR TEAM IS HERE TO HELP

implement thoughtful features into each ideas and deliver on our promises. space that enhance user experience design environments to spark creativity and experiences for their people.

KEEP THINGS ON TRACK

- We are passionate about human-centric design
 - We listen to our clients, respectfully exchange • We
 - We are honored that so many entrust Paragon • We
- to contribute toward their unique culture and nurture collaboration enrich daily

Team Descriptions

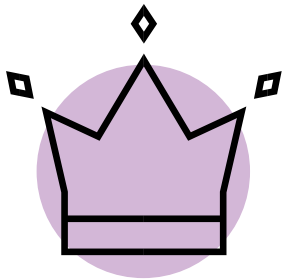

Leadership

Mary and Linda guide the long-term vision and ensure alignment with the mission and values of Paragon Interiors.



Sales Team

Strong customer relations leading to future partnerships

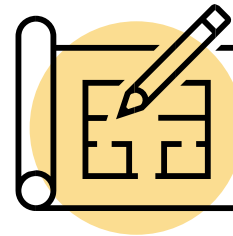

Design Team

Extremely creative, detail-oriented and experienced.



Services Team

Responsible for all coordination and communication regarding project installation



Partnered Install Team

Performs the necessary work to get the job completed on time and on target





Design Deliverables

Finance Office

Workstation

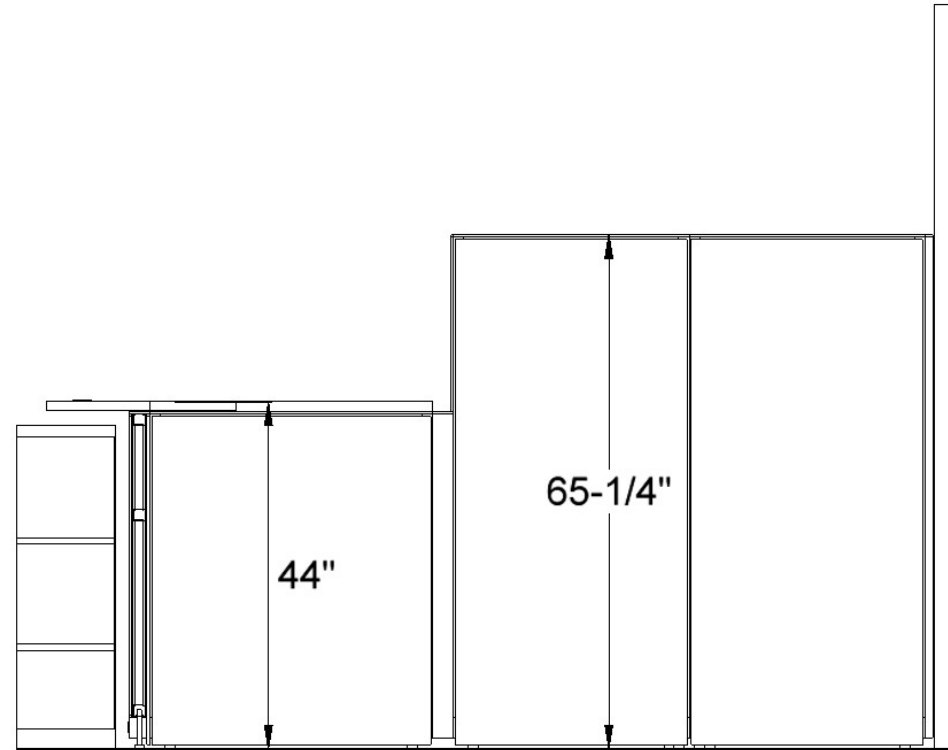
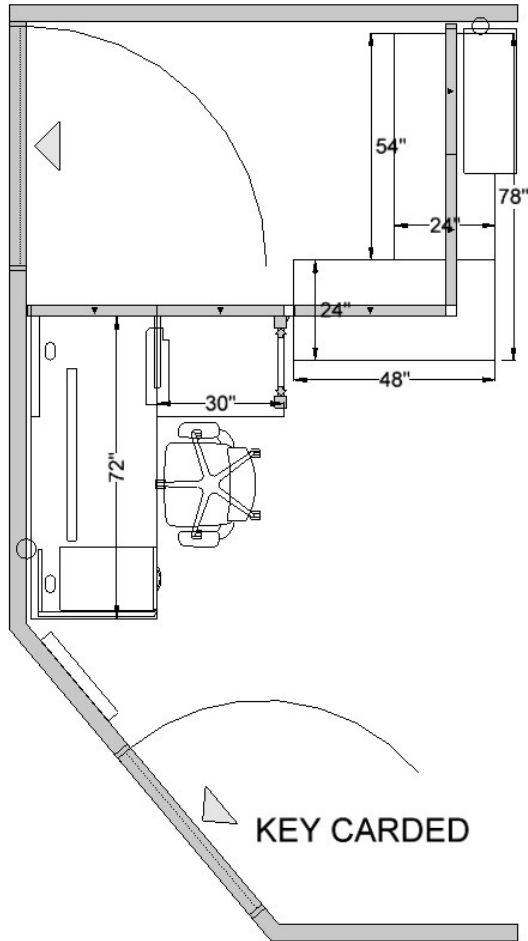

product net price \$7270.58
installation \$1270.00

Finance

Workstation Renderings





THANK
YOU!

Visit our experience centers:

1559 Grant St. Suite 101, Bettendorf, IA 52722

1129 Depot Lane SE Suite 104, Cedar Rapids, IA 52401

319.200.5400 • paragoninteriors.com

paragon interiors



City of Muscatine

ITEM NUMBER 2026-0035

AGENDA ITEM SUMMARY

DATE: 2/3/2026

STAFF

SUBJECT

Request to Approve Subgrant Agreements for the Paul Bruhn Grant

EXECUTIVE SUMMARY

Presented for Council's consideration is a request for approval of two subgrant agreements for the Paul Bruhn Historic Preservation Grant between the City of Muscatine and the owners of the projects located at 113 Iowa and 208 Cedar St.

STAFF RECOMMENDATION

Staff recommends approval of the subgrant agreements.

BACKGROUND/DISCUSSION

Utilizing the Community Grant Writer, in 2023 an application was submitted to the Department of Interior for funding under the Paul Bruhn Historic Preservation Fund. The objective of the fund is to rehabilitate, protect and foster economic development of rural communities through the preservation and rehabilitation of historic properties that have significance at the national or state level. The City is eligible for this funding as a Certified Local Government, and funds must be used for activities that preserve historic sites.

The project budget is \$858,388, including \$747,148 in grant funds to address the preservation needs of up to 11 historic, downtown properties. The grant will support rehabilitation work, including architecture, engineering and construction. The local share, \$111,240, includes the in-kind value of staff time to administer and implement the program as well as private resources and funding available through the existing facade program.

To be eligible, a property must be located in the Downtown Historical District and identified as contributing to the historic district designation. In the first application period, the review committee selected 5 applicants for awards up to \$100,000 to proceed through the grant process. In order to move forward, each property owner must enter into a subgrant agreement with the City to complete the technical review process. Two of the property owners have executed all the documents required to be submitted to the National Parks Service for technical review.

The two subgrants requiring approval at this time are with Ponce Rentals LLC for 113 Iowa Avenue and Anderson Pierson LLC for 2028 Cedar Street each for \$100,000. A minimum 10% match is required for each property, but most projects require significantly more private investment as is demonstrated by these three agreements.

CITY FINANCIAL IMPACT

There is no impact to the general fund for accepting the grant. All local resources are in-kind, available through the local facade program or the private investment required of property owners.

ATTACHMENTS

- 1. DHRP Subgrant Agreement
- 2. DHRP Subgrant Agreement

**CITY OF MUSCATINE SUBGRANT PROGRAM
MUSCATINE DOWNTOWN HISTORIC REVITALIZATION PROJECT (DHRP)
SUBGRANT AGREEMENT**

Period of Performance Start and End Dates: 09/01/2023 to 08/31/2026

Budget Period Start and End Dates: 09/01/2023 to 08/31/2026

Title of Project: Façade Restoration – 113 Iowa

Subgrantee Name: Ponce Rentals

Subgrantee UEI:

Subgrantee Authorizing Official Contact Information:

Ponce Rentals
1484 Isett Ave
Muscatine, IA 52761

City of Muscatine Contact information

Project Coordinator:

April Limburg
215 Sycamore St
Muscatine, IA 52761
563-262-4141
alimburg@muscatineiowa.gov

Amount of Federal Funds Obligated: \$100,000

Total Amount of Federal Funds Obligated: \$100,000

Total Amount of the Federal Award Committed: \$0

Amount of Non-federal Funds: \$445,000

Federal Award Project Description: The purpose of the Muscatine Downtown Historic Revitalization Project Subgrant Program is to support the revitalization of Muscatine through the redevelopment of downtown commercial properties.

FAIN: P23APO1973

Name of Federal Awarding Agency: National Park Service, Department of the Interior

Assistance Listing Number and Title: 15.904 Paul Bruhn Historic Revitalization Subgrant Program

R&D Award: No.

Indirect Cost Rate: Not Applicable.

The Muscatine Historic Revitalization Subgrant Program is being supported in part by the Historic Preservation Fund (HPF) administered by the National Park Service, Department of the Interior.

This Grant Agreement is entered into by City of Muscatine and Ponce Rentals, LLC (Recipient).

ARTICLE 1 – AUTHORITY

Upon signature of both parties below, City of Muscatine enters into this Agreement pursuant to the National Historic Preservation Act, as amended (54 USC 302301, 302901, and 303101; CFDA 15.904) and the Paul Bruhn Historic Revitalization Grant Program. Recipient warrants that it has the legal authority to accept the federal grant and to finance and complete the scope of work for the funded project within the period of performance.

ARTICLE II - SCOPE OF WORK

The Scope of Work to be performed is in accordance with the *Secretary of the Interior's Standards and Guidelines for Archeology and Historic Preservation* and as determined eligible in the National Historic Preservation Act (NHPA), 54 U.S.C 300101 et. seq., and in the Historic Preservation Grant Fund Manual, as applicable to Tribes.

The Scope of Work is further defined in an addendum at the end of this Notice of Award.

Recipient agrees to perform project work in accordance with the *Secretary of the Interior's Standards for Rehabilitation* as defined by the National Historic Preservation Act.

ARTICLE III - SCHEDULE

Recipient agrees not to incur project costs prior to the execution of this Agreement. Semi-annual progress reports will be required as detailed in the addendum. The project must be complete on or before August 31, 2026.

Proposed Schedule:

| | |
|-----------------|---|
| February 2025 | Sub-grantee Workshop |
| April-May 2025 | Environmental and Technical Review |
| June 2025 | Procurement/Bid Solicitation |
| July 2025 | Notice to Proceed and begin the project |
| August 31, 2026 | Deadline to complete construction |

ARTICLE IV – BUDGET

The Recipient shall obtain prior written approval from Program Coordinator and City of Muscatine for budget, scope, or schedule revisions. Budget detail is provided in the addendum to this Agreement. Recipient agrees to contribute eligible non-Federal matching contributions that are allowable, properly documented and used during the grant period in the amount specified in the addendum to this Agreement.

ARTICLE V - KEY OFFICIALS AND COMMUNICATION

Key officials are essential to ensure optimal coordination and communications between the parties and the work being performed. Key officials for City of Muscatine and the Recipient are identified on the cover page of this Agreement.

All communications regarding project reviews, approvals and grant payments shall be conducted by

Program Coordinator. Recipient agrees to submit all required documentation and reports to Program Coordinator over the course of the project.

ARTICLE VI - AWARD & PAYMENT

- A. City of Muscatine will provide funding for the scope of work described in Article II, the addendum to this Agreement, and in accordance with the approved budget provided in the addendum to this Agreement.
- B. Method of Payment. Payment will be made by reimbursement upon submission of documented project expenses according to the approved project budget. Payment will be in the form of check and will be mailed to the recipient.
- C. Requesting Reimbursement. Requests for reimbursements must be submitted via email to the Program Coordinator. Each request must be submitted on the reimbursement request form indicating the total expenditure and the amount requested for reimbursement. Supporting documentation in the form of itemized receipts or invoices must be provided for all expenses.
- D. Review of Documentation. Prior to payment, all supporting documentation will be reviewed by the City of Muscatine and a qualified architect contracted by the City of Muscatine.
- E. Project expenses may not be incurred prior to the period of performance and may be incurred only as necessary to carry out the approved objectives and scope of work as outlined in the approved budget. Recipient shall not incur costs or obligate funds for any purpose pertaining this project beyond the period of performance.

ARTICLE VII – REPORTS AND DELIVERABLES

- A. Recipient will report on the funded project every six months. The following reporting period end dates shall be used for both progress and financial reports. All reports shall be submitted via email to the Program Coordinator.

| Period Begin Date | Period End Date | Reporting Type | Report Due Date |
|-------------------|-----------------|----------------|-----------------|
| 10/1/2024 | 3/31/2025 | Semi-annual | 4/15/2025 |
| 4/1/2025 | 9/30/2025 | Semi-annual | 10/15/2025 |
| 10/1/2025 | 3/31/2026 | Semi-annual | 4/15/2026 |
| 3/1/2026 | 8/31/2026 | Final | 9/15/2026 |

Other required submissions and deliverables are listed in the addendum to this Agreement.

ARTICLE VIII - MODIFICATION, REMEDIES FOR NONCOMPLIANCE, TERMINATION

- A. This Agreement may be modified at any time, prior to the expiration date, only by a written instrument executed by both parties. Modifications will be in writing and approved by the City of Muscatine. Additional conditions may be imposed by the City of Muscatine if it is determined that the Recipient is non-compliant with the terms and conditions of this Agreement.
- B. This project may be terminated in whole or in part as follows:
 - 1. By the City of Muscatine if the Recipient fails to comply with the terms and conditions herein.
 - 2. By the City of Muscatine for any other cause.

3. By the City of Muscatine with the consent of the Recipient, in which case the two parties must agree upon the termination conditions, including the effective date and, in the case of partial termination, the portion to be terminated: or
 4. By the Recipient upon sending to the City of Muscatine written notification setting forth the reasons for such termination, the effective date, and, in the case of partial termination, the portion to be terminated. However, if the City of Muscatine determines in the case of partial termination that the reduced or modified portion of the grant award will not accomplish the purposes for which the award was made, the City of Muscatine may terminate the grant award in its entirety.
- C. In the event that performance is delayed by a natural disaster, pandemic, Act of God, war, insurrection, work stoppage, government order or directive, or other event or condition that is beyond the control of the parties, then further time for performance may be added to any date or deadline if authorized by the National Park Service, except that, in the event that the delay in performance shall continue for thirty (30) days, City of Muscatine may, with the approval of the National Park Service, terminate this Agreement as of an effective date selected by the terminating party that is beyond the thirty (30) day period of delay. In such events, the Parties shall equitably adjust payment and other terms and conditions as authorized by the National Park Service.

ARTICLE IX – HISTORIC PRESERVATION FUND SPECIAL CONDITIONS

- A. City of Muscatine Responsibilities: City of Muscatine is responsible for the following
1. Review and approval of progress and final reporting to include compliance with 2 CFR 200.
 2. Approval of recipient plans and specifications for compliance with the *Secretary of the Interior's Standards for Rehabilitation*.
 3. Review and approval of project plans and specifications for compliance with Sections 106 (54 U.S.C. § 306108) and 110f (54 U.S.C. § 306107) of the National Historic Preservation Act.
 4. Review and approval for compliance with the National Environmental Policy Act (NEPA).
 5. Providing Recipient with project signage to notify the public of federal involvement.
 6. Any other reviews as determined by the City of Muscatine and NPS based on program needs or financial/programmatic risk factors.
- B. Eligible Costs: Eligible costs under this award are as described in this Agreement and in the Historic Preservation Fund Grants Manual. For this program they include
1. Costs to develop architectural/engineering plans and specifications. Such costs must be incurred during the grant period and may not exceed 20% of the total project cost or \$5,000, whichever is more.
 2. Preservation of properties that contribute to Muscatine's Historic Districts listed in the National Register.
- C. Project Sign: Physical preservation projects must create public notification of the project in the form of a project sign. The City of Muscatine will provide the subgrantee with approved signage for display in a high visibility location at the project site. Photographs of the project sign in place must be submitted as part of the initial progress report. The project sign is to remain in place through project completion.
- D. Publicity & Press Releases: Press releases about this project must acknowledge the grant assistance provided by the Historic Preservation Fund and the National Park Service, and copies of the press

releases must be provided to the Program Coordinator prior to issuance. All publicity and press releases related to activities funded with this award should include the following statement:

“This project is supported by a grant from the Paul Bruhn Historic Revitalization Grants Program administered at the federal level by the National Park Service, Department of Interior, and by City of Muscatine.”

- E. **Consultants & Contractors:** Consultant(s)/contractor(s) must have the requisite experience and training in historic preservation or relevant field to oversee the project work. All consultants and contractors must be competitively selected, and their qualifications forwarded to the Program Coordinator for review of compliance with *the Secretary of the Interior’s Professional Qualification Standards*. Consultants and contractors must agree to comply fully with all applicable laws and regulations in the conduct of activities specified in this Agreement. See Article X, Section B. 7. for additional information.
- F. **Preservation Easement/Covenant Requirement:** Section 54 USC 302902 of the National Historic Preservation Act requires Historic Preservation Fund grantees agree to assume, after the completion of the project, the total cost of continued maintenance, repair and administration of the grant-assisted property in a manner satisfactory to the Secretary of the Interior. Accordingly, subgrantees awarded funds for the physical preservation of a historic site shall sign a preservation covenant/easement with the City of Muscatine.

A preservation easement must be executed and recorded by registering it with the deed of the property. Baseline documentation of the character defining features of the site must be documented prior to construction through photographs. The preservation easement must document the grant assisted condition of the site and the historic character defining features as part of the document registered with the deed.

The preservation easement must be executed before 50% of the grant funds are drawn down or by July 15, 2025, whichever is earlier. If 49% of the grant funds are drawn down prior to execution of the preservation easement, the remaining funds will be held until the easement is executed.

The term of the preservation easement is dependent on the amount of assistance the historic property receives from this opportunity as described below:

- 1. If the historic property is not currently protected by a preservation easement, a preservation easement must be executed for the term as given in the table below per the amount of funding awarded.
- 2. If the historic property is currently subject to a preservation easement that meets the minimum federal preservation requirements, an extension must be executed for an additional duration to meet the requirements of the new funding awarded. Required term is identified in the table below. For example, if a property had 5 years remaining on a previous 20-year easement, and receives \$60,000 in HPF funding, an amendment to add 5 years would be required.
- 3. If the historic property is currently protected by a perpetual or other preservation easement that meets or exceeds the requirements of this grant program as determined by

the NPS, no additional duration or restrictions are necessary.

| Amount of Federal Assistance Awarded | Covenant/Easement Term Requirement |
|--------------------------------------|---|
| \$1-\$50,000 | 5-year minimum preservation covenant/easement amending the deed is not required |
| \$50,001 - \$250,000 | 10-year minimum preservation covenant/easement |

G. City of Muscatine Review of Plans and Specifications and Project Work:

1. Prior to the Notice to Proceed, Recipient agrees to submit the following documentation to the Program Coordinator for review to enable the Federal Environmental Review to be complete. Program Coordinator will obtain State Historic Preservation Office and National Park Service approvals as necessary and provide documentation of approval to Recipient.
 - a. Multiple estimates for each work element (if not included in application).
 - b. A site plan that has the north direction clearly marked.
 - c. Plans and specifications for planned construction work to the building that will take place during the project period of this Agreement or fall under review during the covenant period.
 - d. Digital images of all exterior elevations of the building or site, with views identified and oriented and keyed to the site plan, as applicable.
 - e. Interior photographs (if applicable) of all major rooms and those involved in the project, labeled and keyed to a floor plan.
 - f. Any additional information as may be requested by the Program Coordinator that will better enable a technical review of the project to be completed. This may include cut sheets and product samples.
 - g. A narrative (if applicable) describing ground disturbance including distance from the building, diameter, depth, width, grading and sloping.

2. The Recipient must submit documents for the entire undertaking to the Program Coordinator. All work to be undertaken during the project period will be reviewed for conformance with the *Secretary of the Interior's Standards for Rehabilitation* prior to the beginning of grant-assisted work. Work that does not conform with the standards in the judgement of the Program Coordinator and National Park Service will not be reimbursed and may cause the grant to be terminated.

3. An architect experienced in historic preservation contracted by the City of Muscatine will inspect each project periodically and/or prior to each disbursement to ensure that all work completed on the property during the grant period regardless of funding source is compliant with the *Secretary of the Interior's Standards for Historic Preservation* and aligns with plans and specifications approved by the City of Muscatine and the National Park Service. Inspection reports will be submitted to the City for review and concurrence. Work that does not conform with the standards in the judgement of the architect, Program Coordinator, and National Park Service will not be reimbursed and may cause the grant to be terminated.

- H. Compliance with ADA and ABA: The use of federal funds to improve public buildings, finance services or programs contained in public buildings, or alter any building or facility financed in whole or in part with Federal funds (except privately owned residential structures), requires compliance with the 1990 Americans with Disabilities Act (ADA), Section 504 of the Rehabilitation Act of 1973, and the Architectural Barriers Act (ABA). Work done to alter the property should be in compliance

with all applicable regulations and guidance.

- I. Unanticipated Discovery Protocols: If project work includes ground disturbance and cultural resources are discovered in the course of project work, Recipient agrees that at a minimum, its contractors will immediately stop construction in the vicinity of the affected historic resource and take reasonable measures to avoid and minimize harm to the resources until the State Historic Preservation Officer and/or Tribal Historic Preservation Officer (THPO), sub-Recipient or contractor, and Indian Tribes, as appropriate, have determined a suitable course of action within 15 calendar days.

With the express permission of the City of Muscatine, the Recipient or contractor may perform additional measures to secure the jobsite if the Recipient or contractor determines that unfinished work in the vicinity of the affected historic property would cause safety or security concerns.

- J. Requirement for Training: At the direction of the City of Muscatine, personnel associated with management of the grant program will be required to attend trainings and/or meetings. The grantee will be provided adequate notice to plan for any required activities.
- K. Demonstration of Effort - Performance Goals: In order to ensure the timely and successful completion of all HPF grant awards, the City of Muscatine requires acceptable demonstration of effort by the Recipient on project work supported by all HPF funded grants.

Demonstration of effort means acceptable performance by undertaking meaningful progress on subgrant-supported activities and complying with award terms and conditions.

ARTICLE X - GENERAL & SPECIAL PROVISIONS

A. General Provisions

1. OMB Circulars and Other Regulations. The following Federal regulations are incorporated by reference into this Agreement (full text can be found at <http://www.ecfr.gov>):
 - a. Administrative Requirements: 2 CFR, Part 200.331-333 – Subrecipient and contractor determinations, Requirements for pass-through entities, and Fixed amount subawards [eCFR :: 2 CFR Part 200 -- Uniform Administrative Requirements, Cost Principles, and Audit Requirements for Federal Awards](#)
 - b. Determination of Allowable Costs: 2 CFR, Part 200 – Uniform Administrative Requirements, Cost Principles, and Audit Requirements for Federal Awards, Subpart E and Subpart F
 - c. Code of Federal Regulations/Regulatory Requirements: [2 CFR Part 182 & 1401, "Government-wide Requirements for a Drug-Free Workplace"](#);
 - d. 2 CFR 180 & 1400, "Non-Procurement Debarment and Suspension", previously located at 43 CFR Part 42, "Governmentwide Debarment and Suspension (Non-Procurement)." Prior to entering contract, Recipient agrees to visit <https://www.sam.gov/SAM/pages/public/searchRecords/search.jsf> to check whether contractors selected for this project are currently debarred.
 - e. [43 CFR 18, "New Restrictions on Lobbying"](#):

SUBGRANT AGREEMENT

Subgrant Number: MHRSP-2024-113

Date Issued: 8/30/2024

- f. 2 CFR Part 175, "[Trafficking Victims Protection Act of 2000](#)".
 - g. FAR Clause 52.203–12, Paragraphs (a) and (b), Limitation on Payments to Influence Certain Federal Transactions.
2. Non-Discrimination. All activities pursuant to this Agreement shall be in compliance with the requirements of Executive Order 11246, as amended; Title VI of the Civil Rights Act of 1964, as amended, (78 Stat. 252; 42 U.S.C. §§2000d et seq.); Title V, Section 504 of the Rehabilitation Act of 1973, as amended, (87 Stat. 394; 29 U.S.C. §794); the Age Discrimination Act of 1975 (89 Stat. 728; 42 U.S.C. §§6101 et seq.); and with all other Federal laws and regulations prohibiting discrimination on grounds of race, color, sexual orientation, national origin, disabilities, religion, age, or sex.
3. Lobbying Prohibition. 18 U.S.C. §1913, Lobbying with Appropriated Moneys, as amended by Public Law 107–273, Nov. 2, 2002. No part of the money appropriated by any enactment of Congress shall, in the absence of express authorization by Congress, be used directly or indirectly to pay for any personal service, advertisement, telegram, telephone, letter, printed or written matter, or other device, intended or designed to influence in any manner a Member of Congress, a jurisdiction, or an official of any government, to favor, adopt, or oppose, by vote or otherwise, any legislation, law, ratification, policy, or appropriation, whether before or after the introduction of any bill, measure, or resolution proposing such legislation, law, ratification, policy, or appropriation; but this shall not prevent officers or employees of the United States or of its departments or agencies from communicating to any such Members or official, at his request, or to Congress or such official, through the proper official channels, requests for legislation, law, ratification, policy, or appropriations which they deem necessary for the efficient conduct of the public business, or from making any communication whose prohibition by this section might, in the opinion of the Attorney General, violate the Constitution or interfere with the conduct of foreign policy, counter-intelligence, intelligence, or national security activities. Violations of this section shall constitute violations of section 1352(a) of title 31. In addition, the related restrictions on the use of appropriated funds found in Div. F, § 402 of the Omnibus Appropriations Act of 2008 (P.L. 110–161) also apply.
4. Buy American Act. Pursuant to Section 307 of the Omnibus Consolidated Appropriations Act of 1997, Public Law 104-208, 110 Stat. 3009, Recipient agrees to follow the requirements in 43 CFR Part 12, Subpart E, Buy American Requirements for Assistance Programs. In the case of any equipment or product that may be authorized to be purchased with financial assistance provided using funds made available in this Act, it is the sense of the Congress that entities receiving the assistance should, in expending the assistance, purchase only American-made equipment and products.
5. Per Executive Order 13858, entitled "Strengthening Buy-American Preferences for Infrastructure Projects" the Recipient shall maximize, consistent with law, the use of iron and steel goods, products, and materials produced in the United States, for infrastructure projects as defined by the Executive Order when the scope of work includes alteration, construction, conversion, demolition, extension, improvement, maintenance, reconstruction, rehabilitation, or repair.
6. Minority Business Enterprise Development. Pursuant to Executive Order 12432 it is national policy to award a fair share of contracts to small and minority firms. See Article X, Section B.5. for additional information.
7. Assignment. No part of this Agreement shall be assigned to any other party without prior written approval of the Program Coordinator.
8. Member of Congress. Pursuant to 41 U.S.C. § 22, no Member of Congress shall be admitted to any share or part of any contract or Agreement made, entered into, or adopted by or on behalf of the United States, or to any benefit to arise thereupon.

9. Agency. The Recipient is not an agent or representative of the United States, the Department of the Interior, the City of Muscatine, the National Park Service, nor will the Recipient represent itself as such to third parties. The City of Muscatine employees are not agents of the Recipient and will not act on behalf of the Recipient.
10. Non-Exclusive Agreement. This Agreement in no way restricts the Recipient or the City of Muscatine from entering into similar Agreements or participating in similar activities or arrangements with other public or private agencies, organizations, or individuals.
11. Survival. Any and all provisions which, by themselves or their nature, are reasonably expected to be performed after the expiration or termination of this Agreement shall survive and be enforceable after the expiration or termination of this Agreement. Any and all liabilities, actual or contingent, which have arisen during the term of and in connection with this Agreement shall survive expiration or termination of this Agreement.
12. Partial Invalidity. If any provision of this Agreement or the application thereof to any party or circumstance shall, to any extent, be held invalid or unenforceable, the remainder of this Agreement or the application of such provision to the parties or circumstances other than those to which it is held invalid or unenforceable, shall not be affected thereby and each provision of this Agreement shall be valid and be enforced to the fullest extent permitted by law.
13. Captions and Headings. The captions, headings, article numbers and paragraph numbers appearing in this Agreement are inserted only as a matter of convenience and in no way shall be construed as defining or limiting the scope or intent of the provision of this Agreement nor in any way affecting this Agreement.
14. Relationship of Parties. This Agreement is not intended to and shall not be construed to create an employment relationship, partnership or joint venture between the City of Muscatine and Recipient or its representatives. No representative of Recipient shall perform any function or make any decision properly reserved by law or policy to the Federal government.
15. No Third-Party Rights. This Agreement creates enforceable obligations between the City of Muscatine and Recipient. Except as expressly provided herein, and related to project oversight by the City of Muscatine, it is not intended nor shall it be construed to create any right of enforcement by or any duties or obligation in favor of persons or entities not a party to this Agreement.
16. Program Income. If the Recipient earns program income, as defined in 2 CFR §200.80, during the period of performance of this Agreement, to the extent available the Recipient must disburse funds available from program income, and interest earned on such funds, before requesting additional cash payments (2 CFR §200.305 (5)). As allowed under 2 CFR §200.307, program income may be added to the Federal award by the Federal agency and the Recipient. The program income must be used for the purposes, and under the conditions of, the Federal award. Disposition of program income remaining after the end of the period of performance shall be negotiated as part of the Agreement closeout process.

B. Special Provisions

1. Public Information and Endorsements
 - a. Recipient shall not publicize or otherwise circulate promotional material (such as advertisements, sales brochures, press releases, speeches, still and motion pictures, articles, manuscripts or other publications) which states or implies the City of Muscatine, governmental, departmental, bureau, or government employee endorsement of a business, product, service,

- or position which the Recipient represents. No release of information relating to this award may state or imply that the Government or the City of Muscatine approves of the Recipient's work products or considers the Recipient's work product to be superior to other products or services.
- b. Recipient must obtain prior approval of Program Coordinator for any public information releases concerning this award which refer to the U.S. Department of the Interior or any bureau or employee (by name or title).
2. **Rights in Data.** The Recipient grants the United States of America a royalty-free, non-exclusive and irrevocable license to publish, reproduce and use, and dispose of in any manner and for any purpose without limitation, and to authorize or ratify publication, reproduction or use by others, of all copyrightable material first produced or composed under this Agreement by the Recipient, its employees or any individual or concern specifically employed or assigned to originate and prepare such material.
 3. **Retention and Access Requirements for Records.** All Recipient financial and programmatic records, supporting documents, statistical records, and other grants-related records shall be maintained and available for access in accordance with 2 CFR Part 200.333-200.337, generally for three years following receipt of the final grant payment.
 4. **Audit Requirements**
 - a. Recipients that expend \$750,000 or more during a year in Federal awards shall have a single or program-specific audit conducted for that year in accordance with the Single Audit Act Amendments of 1996 (31 U.S.C. 7501-7507) and 2 CFR Part 200, Subpart F.
 - b. Recipients that expend less than \$750,000 during a fiscal year in Federal awards are exempt from Federal audit requirements for that year, but records must be available for review or audit by appropriate officials of the Federal agency, General Accounting Office (GAO) and the Ohio History Connection.
 5. **Procurement Procedures.** It is a national policy to place a fair share of purchases with minority business firms. The Department of the Interior is strongly committed to the objectives of this policy and encourages all recipients of its grants and cooperative Agreements to take affirmative steps to ensure such fairness. Positive efforts shall be made by recipients and any contractors and consultants to utilize small businesses, minority-owned firms, and women's business enterprises, whenever possible. Recipients of Federal awards shall take all of the following steps to further this goal:
 - a. Ensure that small businesses, minority-owned firms, and women's business enterprises are used to the fullest extent practicable.
 - b. Make information on forthcoming opportunities available and arrange time frames for purchases and contracts to encourage and facilitate participation by small businesses, minority-owned firms, and women's business enterprises.
 - c. Consider in the contract process whether firms competing for larger contracts intend to subcontract with small businesses, minority-owned firms, and women's business enterprises.
 - d. Encourage contracting with consortiums of small businesses, minority-owned firms and women's business enterprises when a contract is too large for one of these firms to handle

individually.

- e. Use the services and assistance, as appropriate, of such organizations as the Small Business Development Agency in the solicitation and utilization of small business, minority-owned firms and women's business enterprises.
 - f. All procurement transactions, without regard to dollar value, shall be conducted in a manner that provides maximum open and free competition. The Recipient shall use its own procurement procedures that reflect applicable State and local laws and regulations. The City of Muscatine shall review all Requests for Proposals, Invitations to Bid, and/or price quotation documents prior to issuance to ensure that the scope of work meets the applicable Secretary of the Interior's standards. In addition to maintaining acceptable financial records, the Recipient shall maintain records sufficient to detail the history of any procurement and award.
6. Subcontracts. The Recipient may subcontract for the performance of the services and activities herein prescribed. The Recipient should not execute any subcontract until this Grant Agreement, against which costs will be charged, has been executed between the Recipient and the City of Muscatine. Any contract or Agreement prepared by the Recipient shall be submitted to Program Coordinator for review and approval prior to execution. Recipient agrees that subcontracts will not be altered without written approval from Program Coordinator. The execution of subcontracts shall not alter or modify the obligations of the Recipient hereunder.

The Recipient shall not enter into any subcontract wherein the consideration for work or material there under is based upon the "cost-plus-a-percentage-of-cost" or "cost-plus" method. A copy of each executed subcontract entered into for project work shall be forwarded to the City of Muscatine upon execution of the subcontract.

7. Consultant Services. The use of individual consultant services as part of the grant project, funded either by the Federal share or matching share, shall be documented in the following manner: evidence is to be shown that the fee is appropriate considering the qualifications of the consultant, his/her normal charges and the nature of the services to be provided. No person employed as a consultant, or by a firm providing consultant services, shall receive more than a reasonable rate of compensation for personal services paid with federal funds, or when such services are contributed as matching share. This rate shall not exceed the maximum daily rate of compensation in the Federal Civil Service equal to 120 percent of a GS-15, step 10 salary. Written Agreements between the parties shall be executed detailing the responsibilities, standards, and fees. The services of a consultant shall be procured per Section 13 and shall be subject to the provisions of section 14 governing subcontracts. Federal contracting and procurement guidance can be found in 2 CFR 200.318. Maximum rates charged to this grant may not exceed 120% of a Federal Civil Service GS- 15, step 10 salary per project location. Current regional salary tables can be found on the Office of Personnel and Management website: <https://www.opm.gov/policy-data-oversight/pay-leave/salaries-wages/>.
8. Professional Qualifications of Principal Project Personnel. Principal project personnel must meet appropriate professional qualification standards as published in *the Secretary of the Interior's Standards and Guidelines for Archaeology and Historic Preservation*, 48 CFR 44716, incorporated herein, by reference. Principal project personnel may be Recipient staff or a hired consultant or contractor. A copy of personnel's qualifications shall be provided to Program Coordinator upon execution of the Grant Agreement or with the contract if a consultant is being hired.

9. Permits. Recipient agrees to obtain any permits, certificates of appropriateness or other permissions as necessary for the performance of the project work.
10. Trafficking in Persons. This term of award is pursuant to paragraph (g) of Section 106 of the Trafficking Victims Protections Act of 2000, as amended (2 CFR §175.15).
11. Conflict of Interest: Recipients must avoid prohibited conflicts of interest, including any significant financial interests that could cause a reasonable person to question the Recipient's ability to provide impartial, technically sound, and objective performance under or with respect to a Federal financial assistance Agreement. In addition, no key official of the Recipient, who is substantially involved in the proposal or project, may have been a former Federal employee who, within the last one (1) year, participated personally and substantially in the evaluation, award, or administration of an award with respect to Recipient or in development of the requirement leading to the funding announcement. Recipient may not solicit, obtain, or use non-public information regarding the evaluation, award, or administration of this award or the development of a Federal financial assistance opportunity that may be of competitive interest to the Recipient.
12. Procurement Process Conflicts of Interest: All individuals involved in the procurement process for this project, including but not limited to employees, consultants, and contractors of the federal grantee, must adhere to the highest standards of integrity and impartiality. No person shall participate in the selection, award, or administration of a contract if a real or apparent conflict of interest would be involved. A conflict of interest arises when any individual, or their immediate family members, partners, or organizations with which the individual is associated, has a financial or other interest in a firm or entity considered for a contract under this project. Immediate family members include, but are not limited to, spouses, domestic partners, parents, children, siblings, and in-laws.

Disclosure Requirements: Any individual who is involved in the procurement process must disclose any potential conflicts of interest as soon as they become known. This includes any familial, financial, or other personal relationships with a firm or its employees that could reasonably appear to affect the individual's objectivity. No contract shall be awarded under this project to any firm or entity in which an immediate family member of any individual involved in the procurement process has a financial interest or is employed in a capacity that could create a conflict of interest unless the conflict is disclosed and a waiver is obtained from the federal awarding agency. The waiver must clearly document that the conflict of interest will not affect the integrity of the procurement process.

Enforcement and Remedies: Failure to comply with this Conflict of Interest Clause may result in disciplinary action, termination of employment or contracts, and other legal remedies. Contracts awarded in violation of this clause may be subject to cancellation, and the grantee may be required to repay any federal funds used in connection with such contracts.

Recipient must disclose in writing any conflict of interest to the Program Coordinator. The federal grantee shall periodically review procurement procedures and practices to ensure compliance with this Conflict of Interest Clause and shall take appropriate steps to address any issues that may arise.

13. Minimum Wages Under Executive Order 13658 (January 2015): In accordance with Executive Order 13658, the minimum wage that must be paid under any contract or subcontract awarded pursuant

to this Agreement is \$12.90 per hour, which must be adjusted annually during the term of this Agreement to meet the Secretary of Labor’s annual E.O. minimum wage Agreement.

ARTICLE XI – SIGNATURES

IN WITNESS WHEREOF, the parties hereto have executed this Agreement on the date(s) set forth below.

FOR THE RECIPIENT

CITY OF MUSCATINE

Name

Name

Title

Title

Date

Date

**CITY OF MUSCATINE SUBGRANT PROGRAM
MUSCATINE DOWNTOWN HISTORIC REVITALIZATION PROJECT (DHRP)
SUBGRANT AGREEMENT**

Period of Performance Start and End Dates: 09/01/2023 to 08/31/2026

Budget Period Start and End Dates: 09/01/2023 to 08/31/2026

Title of Project: Façade Restoration – 208 Cedar St

Subgrantee Name: Anderson Pierson, LLC

Subgrantee UEI:

Subgrantee Authorizing Official Contact Information:

Anderson Pierson, LLC

Andrew Anderson

226 E 2nd St

Muscataine IA 52761-3706

City of Muscatine Contact information

Project Coordinator:

April Limburg

215 Sycamore St

Muscataine, IA 52761

563-262-4141

alimburg@muscatineiowa.gov

Amount of Federal Funds Obligated: \$100,000

Total Amount of Federal Funds Obligated: \$100,000

Total Amount of the Federal Award Committed: \$0

Amount of Non-federal Funds: \$77,200

Federal Award Project Description: The purpose of the Muscatine Downtown Historic Revitalization Project Subgrant Program is to support the revitalization of Muscatine through the redevelopment of downtown commercial properties.

FAIN: P23APO1973

Name of Federal Awarding Agency: National Park Service, Department of the Interior

Assistance Listing Number and Title: 15.904 Paul Bruhn Historic Revitalization Subgrant Program

R&D Award: No.

Indirect Cost Rate: Not Applicable.

The Muscatine Historic Revitalization Subgrant Program is being supported in part by the Historic Preservation Fund (HPF) administered by the National Park Service, Department of the Interior.

This Grant Agreement is entered into by City of Muscatine and Anderson Pierson, LLC (Recipient).

ARTICLE 1 – AUTHORITY

Upon signature of both parties below, City of Muscatine enters into this Agreement pursuant to the National Historic Preservation Act, as amended (54 USC 302301, 302901, and 303101; CFDA 15.904) and the Paul Bruhn Historic Revitalization Grant Program. Recipient warrants that it has the legal authority to accept the federal grant and to finance and complete the scope of work for the funded project within the period of performance.

ARTICLE II - SCOPE OF WORK

The Scope of Work to be performed is in accordance with the *Secretary of the Interior's Standards and Guidelines for Archeology and Historic Preservation* and as determined eligible in the National Historic Preservation Act (NHPA), 54 U.S.C 300101 et. seq., and in the Historic Preservation Grant Fund Manual, as applicable to Tribes.

The Scope of Work is further defined in an addendum at the end of this Notice of Award.

Recipient agrees to perform project work in accordance with the *Secretary of the Interior's Standards for Rehabilitation* as defined by the National Historic Preservation Act.

ARTICLE III - SCHEDULE

Recipient agrees not to incur project costs prior to the execution of this Agreement. Semi-annual progress reports will be required as detailed in the addendum. The project must be complete on or before August 31, 2026.

Proposed Schedule:

| | |
|-----------------|---|
| February 2025 | Sub-grantee Workshop |
| April-May 2025 | Environmental and Technical Review |
| June 2025 | Procurement/Bid Solicitation |
| July 2025 | Notice to Proceed and begin the project |
| August 31, 2026 | Deadline to complete construction |

ARTICLE IV – BUDGET

The Recipient shall obtain prior written approval from Program Coordinator and City of Muscatine for budget, scope, or schedule revisions. Budget detail is provided in the addendum to this Agreement. Recipient agrees to contribute eligible non-Federal matching contributions that are allowable, properly documented and used during the grant period in the amount specified in the addendum to this Agreement.

ARTICLE V - KEY OFFICIALS AND COMMUNICATION

Key officials are essential to ensure optimal coordination and communications between the parties and the work being performed. Key officials for City of Muscatine and the Recipient are identified on the cover page of this Agreement.

All communications regarding project reviews, approvals and grant payments shall be conducted by Program Coordinator. Recipient agrees to submit all required documentation and reports to Program Coordinator over the course of the project.

ARTICLE VI - AWARD & PAYMENT

- A. City of Muscatine will provide funding for the scope of work described in Article II, the addendum to this Agreement, and in accordance with the approved budget provided in the addendum to this Agreement.
- B. Method of Payment. Payment will be made by reimbursement upon submission of documented project expenses according to the approved project budget. Payment will be in the form of check and will be mailed to the recipient.
- C. Requesting Reimbursement. Requests for reimbursements must be submitted via email to the Program Coordinator. Each request must be submitted on the reimbursement request form indicating the total expenditure and the amount requested for reimbursement. Supporting documentation in the form of itemized receipts or invoices must be provided for all expenses.
- D. Review of Documentation. Prior to payment, all supporting documentation will be reviewed by the City of Muscatine and a qualified architect contracted by the City of Muscatine.
- E. Project expenses may not be incurred prior to the period of performance and may be incurred only as necessary to carry out the approved objectives and scope of work as outlined in the approved budget. Recipient shall not incur costs or obligate funds for any purpose pertaining this project beyond the period of performance.

ARTICLE VII – REPORTS AND DELIVERABLES

- A. Recipient will report on the funded project every six months. The following reporting period end dates shall be used for both progress and financial reports. All reports shall be submitted via email to the Program Coordinator.

| Period Begin Date | Period End Date | Reporting Type | Report Due Date |
|-------------------|-----------------|----------------|-----------------|
| 10/1/2024 | 3/31/2025 | Semi-annual | 4/15/2025 |
| 4/1/2025 | 9/30/2025 | Semi-annual | 10/15/2025 |
| 10/1/2025 | 3/31/2026 | Semi-annual | 4/15/2026 |
| 3/1/2026 | 8/31/2026 | Final | 9/15/2026 |

Other required submissions and deliverables are listed in the addendum to this Agreement.

ARTICLE VIII - MODIFICATION, REMEDIES FOR NONCOMPLIANCE, TERMINATION

- A. This Agreement may be modified at any time, prior to the expiration date, only by a written instrument executed by both parties. Modifications will be in writing and approved by the City of Muscatine. Additional conditions may be imposed by the City of Muscatine if it is determined that the Recipient is non-compliant with the terms and conditions of this Agreement.
- B. This project may be terminated in whole or in part as follows:
 - 1. By the City of Muscatine if the Recipient fails to comply with the terms and conditions herein.

2. By the City of Muscatine for any other cause.
 3. By the City of Muscatine with the consent of the Recipient, in which case the two parties must agree upon the termination conditions, including the effective date and, in the case of partial termination, the portion to be terminated: or
 4. By the Recipient upon sending to the City of Muscatine written notification setting forth the reasons for such termination, the effective date, and, in the case of partial termination, the portion to be terminated. However, if the City of Muscatine determines in the case of partial termination that the reduced or modified portion of the grant award will not accomplish the purposes for which the award was made, the City of Muscatine may terminate the grant award in its entirety.
- C. In the event that performance is delayed by a natural disaster, pandemic, Act of God, war, insurrection, work stoppage, government order or directive, or other event or condition that is beyond the control of the parties, then further time for performance may be added to any date or deadline if authorized by the National Park Service, except that, in the event that the delay in performance shall continue for thirty (30) days, City of Muscatine may, with the approval of the National Park Service, terminate this Agreement as of an effective date selected by the terminating party that is beyond the thirty (30) day period of delay. In such events, the Parties shall equitably adjust payment and other terms and conditions as authorized by the National Park Service.

ARTICLE IX – HISTORIC PRESERVATION FUND SPECIAL CONDITIONS

- A. City of Muscatine Responsibilities: City of Muscatine is responsible for the following
1. Review and approval of progress and final reporting to include compliance with 2 CFR 200.
 2. Approval of recipient plans and specifications for compliance with the *Secretary of the Interior's Standards for Rehabilitation*.
 3. Review and approval of project plans and specifications for compliance with Sections 106 (54 U.S.C. § 306108) and 110f (54 U.S.C. § 306107 of the National Historic Preservation Act).
 4. Review and approval for compliance with the National Environmental Policy Act (NEPA).
 5. Providing Recipient with project signage to notify the public of federal involvement.
 6. Any other reviews as determined by the City of Muscatine and NPS based on program needs or financial/programmatic risk factors.
- B. Eligible Costs: Eligible costs under this award are as described in this Agreement and in the Historic Preservation Fund Grants Manual. For this program they include
1. Costs to develop architectural/engineering plans and specifications. Such costs must be incurred during the grant period and may not exceed 20% of the total project cost or \$5,000, whichever is more.
 2. Preservation of properties that contribute to Muscatine's Historic Districts listed in the National Register.
- C. Project Sign: Physical preservation projects must create public notification of the project in the form of a project sign. The City of Muscatine will provide the subgrantee with approved signage for display in a high visibility location at the project site. Photographs of the project sign in place must be submitted as part of the initial progress report. The project sign is to remain in place through project completion.
- D. Publicity & Press Releases: Press releases about this project must acknowledge the grant assistance

provided by the Historic Preservation Fund and the National Park Service, and copies of the press releases must be provided to the Program Coordinator prior to issuance. All publicity and press releases related to activities funded with this award should include the following statement:

“This project is supported by a grant from the Paul Bruhn Historic Revitalization Grants Program administered at the federal level by the National Park Service, Department of Interior, and by City of Muscatine.”

- E. Consultants & Contractors: Consultant(s)/contractor(s) must have the requisite experience and training in historic preservation or relevant field to oversee the project work. All consultants and contractors must be competitively selected, and their qualifications forwarded to the Program Coordinator for review of compliance with *the Secretary of the Interior’s Professional Qualification Standards*. Consultants and contractors must agree to comply fully with all applicable laws and regulations in the conduct of activities specified in this Agreement. See Article X, Section B. 7. for additional information.
- F. Preservation Easement/Covenant Requirement: Section 54 USC 302902 of the National Historic Preservation Act requires Historic Preservation Fund grantees agree to assume, after the completion of the project, the total cost of continued maintenance, repair and administration of the grant-assisted property in a manner satisfactory to the Secretary of the Interior. Accordingly, subgrantees awarded funds for the physical preservation of a historic site shall sign a preservation covenant/easement with the City of Muscatine.

A preservation easement must be executed and recorded by registering it with the deed of the property. Baseline documentation of the character defining features of the site must be documented prior to construction through photographs. The preservation easement must document the grant assisted condition of the site and the historic character defining features as part of the document registered with the deed.

The preservation easement must be executed before 50% of the grant funds are drawn down or by July 15, 2025, whichever is earlier. If 49% of the grant funds are drawn down prior to execution of the preservation easement, the remaining funds will be held until the easement is executed.

The term of the preservation easement is dependent on the amount of assistance the historic property receives from this opportunity as described below:

- 1. If the historic property is not currently protected by a preservation easement, a preservation easement must be executed for the term as given in the table below per the amount of funding awarded.
- 2. If the historic property is currently subject to a preservation easement that meets the minimum federal preservation requirements, an extension must be executed for an additional duration to meet the requirements of the new funding awarded. Required term is identified in the table below. For example, if a property had 5 years remaining on a previous 20-year easement, and receives \$60,000 in HPF funding, an amendment to add 5 years would be required.
- 3. If the historic property is currently protected by a perpetual or other preservation

easement that meets or exceeds the requirements of this grant program as determined by the NPS, no additional duration or restrictions are necessary.

| Amount of Federal Assistance Awarded | Covenant/Easement Term Requirement |
|--------------------------------------|---|
| \$1-\$50,000 | 5-year minimum preservation covenant/easement amending the deed is not required |
| \$50,001 - \$250,000 | 10-year minimum preservation covenant/easement |

G. City of Muscatine Review of Plans and Specifications and Project Work:

1. Prior to the Notice to Proceed, Recipient agrees to submit the following documentation to the Program Coordinator for review to enable the Federal Environmental Review to be complete. Program Coordinator will obtain State Historic Preservation Office and National Park Service approvals as necessary and provide documentation of approval to Recipient.
 - a. Multiple estimates for each work element (if not included in application).
 - b. A site plan that has the north direction clearly marked.
 - c. Plans and specifications for planned construction work to the building that will take place during the project period of this Agreement or fall under review during the covenant period.
 - d. Digital images of all exterior elevations of the building or site, with views identified and oriented and keyed to the site plan, as applicable.
 - e. Interior photographs (if applicable) of all major rooms and those involved in the project, labeled and keyed to a floor plan.
 - f. Any additional information as may be requested by the Program Coordinator that will better enable a technical review of the project to be completed. This may include cut sheets and product samples.
 - g. A narrative (if applicable) describing ground disturbance including distance from the building, diameter, depth, width, grading and sloping.

2. The Recipient must submit documents for the entire undertaking to the Program Coordinator. All work to be undertaken during the project period will be reviewed for conformance with the *Secretary of the Interior's Standards for Rehabilitation* prior to the beginning of grant-assisted work. Work that does not conform with the standards in the judgement of the Program Coordinator and National Park Service will not be reimbursed and may cause the grant to be terminated.

3. An architect experienced in historic preservation contracted by the City of Muscatine will inspect each project periodically and/or prior to each disbursement to ensure that all work completed on the property during the grant period regardless of funding source is compliant with the *Secretary of the Interior's Standards for Historic Preservation* and aligns with plans and specifications approved by the City of Muscatine and the National Park Service. Inspection reports will be submitted to the City for review and concurrence. Work that does not conform with the standards in the judgement of the architect, Program Coordinator, and National Park Service will not be reimbursed and may cause the grant to be terminated.

- H. Compliance with ADA and ABA: The use of federal funds to improve public buildings, finance services or programs contained in public buildings, or alter any building or facility financed in whole or in part with Federal funds (except privately owned residential structures), requires compliance with the 1990 Americans with Disabilities Act (ADA), Section 504 of the Rehabilitation Act of 1973,

and the Architectural Barriers Act (ABA). Work done to alter the property should be in compliance with all applicable regulations and guidance.

- I. Unanticipated Discovery Protocols: If project work includes ground disturbance and cultural resources are discovered in the course of project work, Recipient agrees that at a minimum, its contractors will immediately stop construction in the vicinity of the affected historic resource and take reasonable measures to avoid and minimize harm to the resources until the State Historic Preservation Officer and/or Tribal Historic Preservation Officer (THPO), sub-Recipient or contractor, and Indian Tribes, as appropriate, have determined a suitable course of action within 15 calendar days.

With the express permission of the City of Muscatine, the Recipient or contractor may perform additional measures to secure the jobsite if the Recipient or contractor determines that unfinished work in the vicinity of the affected historic property would cause safety or security concerns.

- J. Requirement for Training: At the direction of the City of Muscatine, personnel associated with management of the grant program will be required to attend trainings and/or meetings. The grantee will be provided adequate notice to plan for any required activities.
- K. Demonstration of Effort - Performance Goals: In order to ensure the timely and successful completion of all HPF grant awards, the City of Muscatine requires acceptable demonstration of effort by the Recipient on project work supported by all HPF funded grants.

Demonstration of effort means acceptable performance by undertaking meaningful progress on subgrant-supported activities and complying with award terms and conditions.

ARTICLE X - GENERAL & SPECIAL PROVISIONS

A. General Provisions

1. OMB Circulars and Other Regulations. The following Federal regulations are incorporated by reference into this Agreement (full text can be found at <http://www.ecfr.gov>):
 - a. Administrative Requirements: 2 CFR, Part 200.331-333 – Subrecipient and contractor determinations, Requirements for pass-through entities, and Fixed amount subawards [eCFR :: 2 CFR Part 200 -- Uniform Administrative Requirements, Cost Principles, and Audit Requirements for Federal Awards](#)
 - b. Determination of Allowable Costs: 2 CFR, Part 200 – Uniform Administrative Requirements, Cost Principles, and Audit Requirements for Federal Awards, Subpart E and Subpart F
 - c. Code of Federal Regulations/Regulatory Requirements: [2 CFR Part 182 & 1401, "Government-wide Requirements for a Drug-Free Workplace"](#);
 - d. 2 CFR 180 & 1400, "Non-Procurement Debarment and Suspension", previously located at 43 CFR Part 42, "Governmentwide Debarment and Suspension (Non-Procurement)." Prior to entering contract, Recipient agrees to visit <https://www.sam.gov/SAM/pages/public/searchRecords/search.jsf> to check whether contractors selected for this project are currently debarred.
 - e. [43 CFR 18, "New Restrictions on Lobbying"](#):

SUBGRANT AGREEMENT

Subgrant Number: MHRSP-2024-208

Date Issued: 8/30/2024

- f. 2 CFR Part 175, "[Trafficking Victims Protection Act of 2000](#)".
 - g. FAR Clause 52.203–12, Paragraphs (a) and (b), Limitation on Payments to Influence Certain Federal Transactions.
2. Non-Discrimination. All activities pursuant to this Agreement shall be in compliance with the requirements of Executive Order 11246, as amended; Title VI of the Civil Rights Act of 1964, as amended, (78 Stat. 252; 42 U.S.C. §§2000d et seq.); Title V, Section 504 of the Rehabilitation Act of 1973, as amended, (87 Stat. 394; 29 U.S.C. §794); the Age Discrimination Act of 1975 (89 Stat. 728; 42 U.S.C. §§6101 et seq.); and with all other Federal laws and regulations prohibiting discrimination on grounds of race, color, sexual orientation, national origin, disabilities, religion, age, or sex.
3. Lobbying Prohibition. 18 U.S.C. §1913, Lobbying with Appropriated Moneys, as amended by Public Law 107–273, Nov. 2, 2002. No part of the money appropriated by any enactment of Congress shall, in the absence of express authorization by Congress, be used directly or indirectly to pay for any personal service, advertisement, telegram, telephone, letter, printed or written matter, or other device, intended or designed to influence in any manner a Member of Congress, a jurisdiction, or an official of any government, to favor, adopt, or oppose, by vote or otherwise, any legislation, law, ratification, policy, or appropriation, whether before or after the introduction of any bill, measure, or resolution proposing such legislation, law, ratification, policy, or appropriation; but this shall not prevent officers or employees of the United States or of its departments or agencies from communicating to any such Members or official, at his request, or to Congress or such official, through the proper official channels, requests for legislation, law, ratification, policy, or appropriations which they deem necessary for the efficient conduct of the public business, or from making any communication whose prohibition by this section might, in the opinion of the Attorney General, violate the Constitution or interfere with the conduct of foreign policy, counter-intelligence, intelligence, or national security activities. Violations of this section shall constitute violations of section 1352(a) of title 31. In addition, the related restrictions on the use of appropriated funds found in Div. F, § 402 of the Omnibus Appropriations Act of 2008 (P.L. 110–161) also apply.
4. Buy American Act. Pursuant to Section 307 of the Omnibus Consolidated Appropriations Act of 1997, Public Law 104-208, 110 Stat. 3009, Recipient agrees to follow the requirements in 43 CFR Part 12, Subpart E, Buy American Requirements for Assistance Programs. In the case of any equipment or product that may be authorized to be purchased with financial assistance provided using funds made available in this Act, it is the sense of the Congress that entities receiving the assistance should, in expending the assistance, purchase only American-made equipment and products.
5. Per Executive Order 13858, entitled "Strengthening Buy-American Preferences for Infrastructure Projects" the Recipient shall maximize, consistent with law, the use of iron and steel goods, products, and materials produced in the United States, for infrastructure projects as defined by the Executive Order when the scope of work includes alteration, construction, conversion, demolition, extension, improvement, maintenance, reconstruction, rehabilitation, or repair.
6. Minority Business Enterprise Development. Pursuant to Executive Order 12432 it is national policy to award a fair share of contracts to small and minority firms. See Article X, Section B.5. for additional information.
7. Assignment. No part of this Agreement shall be assigned to any other party without prior written approval of the Program Coordinator.
8. Member of Congress. Pursuant to 41 U.S.C. § 22, no Member of Congress shall be admitted to any share or part of any contract or Agreement made, entered into, or adopted by or on behalf of the United States, or to any benefit to arise thereupon.

9. Agency. The Recipient is not an agent or representative of the United States, the Department of the Interior, the City of Muscatine, the National Park Service, nor will the Recipient represent itself as such to third parties. The City of Muscatine employees are not agents of the Recipient and will not act on behalf of the Recipient.
10. Non-Exclusive Agreement. This Agreement in no way restricts the Recipient or the City of Muscatine from entering into similar Agreements or participating in similar activities or arrangements with other public or private agencies, organizations, or individuals.
11. Survival. Any and all provisions which, by themselves or their nature, are reasonably expected to be performed after the expiration or termination of this Agreement shall survive and be enforceable after the expiration or termination of this Agreement. Any and all liabilities, actual or contingent, which have arisen during the term of and in connection with this Agreement shall survive expiration or termination of this Agreement.
12. Partial Invalidity. If any provision of this Agreement or the application thereof to any party or circumstance shall, to any extent, be held invalid or unenforceable, the remainder of this Agreement or the application of such provision to the parties or circumstances other than those to which it is held invalid or unenforceable, shall not be affected thereby and each provision of this Agreement shall be valid and be enforced to the fullest extent permitted by law.
13. Captions and Headings. The captions, headings, article numbers and paragraph numbers appearing in this Agreement are inserted only as a matter of convenience and in no way shall be construed as defining or limiting the scope or intent of the provision of this Agreement nor in any way affecting this Agreement.
14. Relationship of Parties. This Agreement is not intended to and shall not be construed to create an employment relationship, partnership or joint venture between the City of Muscatine and Recipient or its representatives. No representative of Recipient shall perform any function or make any decision properly reserved by law or policy to the Federal government.
15. No Third-Party Rights. This Agreement creates enforceable obligations between the City of Muscatine and Recipient. Except as expressly provided herein, and related to project oversight by the City of Muscatine, it is not intended nor shall it be construed to create any right of enforcement by or any duties or obligation in favor of persons or entities not a party to this Agreement.
16. Program Income. If the Recipient earns program income, as defined in 2 CFR §200.80, during the period of performance of this Agreement, to the extent available the Recipient must disburse funds available from program income, and interest earned on such funds, before requesting additional cash payments (2 CFR §200.305 (5)). As allowed under 2 CFR §200.307, program income may be added to the Federal award by the Federal agency and the Recipient. The program income must be used for the purposes, and under the conditions of, the Federal award. Disposition of program income remaining after the end of the period of performance shall be negotiated as part of the Agreement closeout process.

B. Special Provisions

1. Public Information and Endorsements
 - a. Recipient shall not publicize or otherwise circulate promotional material (such as advertisements, sales brochures, press releases, speeches, still and motion pictures, articles, manuscripts or other publications) which states or implies the City of Muscatine, governmental, departmental, bureau, or government employee endorsement of a business, product, service,

- or position which the Recipient represents. No release of information relating to this award may state or imply that the Government or the City of Muscatine approves of the Recipient's work products or considers the Recipient's work product to be superior to other products or services.
- b. Recipient must obtain prior approval of Program Coordinator for any public information releases concerning this award which refer to the U.S. Department of the Interior or any bureau or employee (by name or title).
2. **Rights in Data.** The Recipient grants the United States of America a royalty-free, non-exclusive and irrevocable license to publish, reproduce and use, and dispose of in any manner and for any purpose without limitation, and to authorize or ratify publication, reproduction or use by others, of all copyrightable material first produced or composed under this Agreement by the Recipient, its employees or any individual or concern specifically employed or assigned to originate and prepare such material.
 3. **Retention and Access Requirements for Records.** All Recipient financial and programmatic records, supporting documents, statistical records, and other grants-related records shall be maintained and available for access in accordance with 2 CFR Part 200.333-200.337, generally for three years following receipt of the final grant payment.
 4. **Audit Requirements**
 - a. Recipients that expend \$750,000 or more during a year in Federal awards shall have a single or program-specific audit conducted for that year in accordance with the Single Audit Act Amendments of 1996 (31 U.S.C. 7501-7507) and 2 CFR Part 200, Subpart F.
 - b. Recipients that expend less than \$750,000 during a fiscal year in Federal awards are exempt from Federal audit requirements for that year, but records must be available for review or audit by appropriate officials of the Federal agency, General Accounting Office (GAO) and the Ohio History Connection.
 5. **Procurement Procedures.** It is a national policy to place a fair share of purchases with minority business firms. The Department of the Interior is strongly committed to the objectives of this policy and encourages all recipients of its grants and cooperative Agreements to take affirmative steps to ensure such fairness. Positive efforts shall be made by recipients and any contractors and consultants to utilize small businesses, minority-owned firms, and women's business enterprises, whenever possible. Recipients of Federal awards shall take all of the following steps to further this goal:
 - a. Ensure that small businesses, minority-owned firms, and women's business enterprises are used to the fullest extent practicable.
 - b. Make information on forthcoming opportunities available and arrange time frames for purchases and contracts to encourage and facilitate participation by small businesses, minority-owned firms, and women's business enterprises.
 - c. Consider in the contract process whether firms competing for larger contracts intend to subcontract with small businesses, minority-owned firms, and women's business enterprises.
 - d. Encourage contracting with consortiums of small businesses, minority-owned firms and women's business enterprises when a contract is too large for one of these firms to handle

individually.

- e. Use the services and assistance, as appropriate, of such organizations as the Small Business Development Agency in the solicitation and utilization of small business, minority-owned firms and women's business enterprises.
 - f. All procurement transactions, without regard to dollar value, shall be conducted in a manner that provides maximum open and free competition. The Recipient shall use its own procurement procedures that reflect applicable State and local laws and regulations. The City of Muscatine shall review all Requests for Proposals, Invitations to Bid, and/or price quotation documents prior to issuance to ensure that the scope of work meets the applicable Secretary of the Interior's standards. In addition to maintaining acceptable financial records, the Recipient shall maintain records sufficient to detail the history of any procurement and award.
6. Subcontracts. The Recipient may subcontract for the performance of the services and activities herein prescribed. The Recipient should not execute any subcontract until this Grant Agreement, against which costs will be charged, has been executed between the Recipient and the City of Muscatine. Any contract or Agreement prepared by the Recipient shall be submitted to Program Coordinator for review and approval prior to execution. Recipient agrees that subcontracts will not be altered without written approval from Program Coordinator. The execution of subcontracts shall not alter or modify the obligations of the Recipient hereunder.

The Recipient shall not enter into any subcontract wherein the consideration for work or material there under is based upon the "cost-plus-a-percentage-of-cost" or "cost-plus" method. A copy of each executed subcontract entered into for project work shall be forwarded to the City of Muscatine upon execution of the subcontract.

7. Consultant Services. The use of individual consultant services as part of the grant project, funded either by the Federal share or matching share, shall be documented in the following manner: evidence is to be shown that the fee is appropriate considering the qualifications of the consultant, his/her normal charges and the nature of the services to be provided. No person employed as a consultant, or by a firm providing consultant services, shall receive more than a reasonable rate of compensation for personal services paid with federal funds, or when such services are contributed as matching share. This rate shall not exceed the maximum daily rate of compensation in the Federal Civil Service equal to 120 percent of a GS-15, step 10 salary. Written Agreements between the parties shall be executed detailing the responsibilities, standards, and fees. The services of a consultant shall be procured per Section 13 and shall be subject to the provisions of section 14 governing subcontracts. Federal contracting and procurement guidance can be found in 2 CFR 200.318. Maximum rates charged to this grant may not exceed 120% of a Federal Civil Service GS- 15, step 10 salary per project location. Current regional salary tables can be found on the Office of Personnel and Management website: <https://www.opm.gov/policy-data-oversight/pay-leave/salaries-wages/>.
8. Professional Qualifications of Principal Project Personnel. Principal project personnel must meet appropriate professional qualification standards as published in *the Secretary of the Interior's Standards and Guidelines for Archaeology and Historic Preservation*, 48 CFR 44716, incorporated herein, by reference. Principal project personnel may be Recipient staff or a hired consultant or contractor. A copy of personnel's qualifications shall be provided to Program Coordinator upon execution of the Grant Agreement or with the contract if a consultant is being hired.

9. Permits. Recipient agrees to obtain any permits, certificates of appropriateness or other permissions as necessary for the performance of the project work.
10. Trafficking in Persons. This term of award is pursuant to paragraph (g) of Section 106 of the Trafficking Victims Protections Act of 2000, as amended (2 CFR §175.15).
11. Conflict of Interest: Recipients must avoid prohibited conflicts of interest, including any significant financial interests that could cause a reasonable person to question the Recipient's ability to provide impartial, technically sound, and objective performance under or with respect to a Federal financial assistance Agreement. In addition, no key official of the Recipient, who is substantially involved in the proposal or project, may have been a former Federal employee who, within the last one (1) year, participated personally and substantially in the evaluation, award, or administration of an award with respect to Recipient or in development of the requirement leading to the funding announcement. Recipient may not solicit, obtain, or use non-public information regarding the evaluation, award, or administration of this award or the development of a Federal financial assistance opportunity that may be of competitive interest to the Recipient.
12. Procurement Process Conflicts of Interest: All individuals involved in the procurement process for this project, including but not limited to employees, consultants, and contractors of the federal grantee, must adhere to the highest standards of integrity and impartiality. No person shall participate in the selection, award, or administration of a contract if a real or apparent conflict of interest would be involved. A conflict of interest arises when any individual, or their immediate family members, partners, or organizations with which the individual is associated, has a financial or other interest in a firm or entity considered for a contract under this project. Immediate family members include, but are not limited to, spouses, domestic partners, parents, children, siblings, and in-laws.

Disclosure Requirements: Any individual who is involved in the procurement process must disclose any potential conflicts of interest as soon as they become known. This includes any familial, financial, or other personal relationships with a firm or its employees that could reasonably appear to affect the individual's objectivity. No contract shall be awarded under this project to any firm or entity in which an immediate family member of any individual involved in the procurement process has a financial interest or is employed in a capacity that could create a conflict of interest unless the conflict is disclosed and a waiver is obtained from the federal awarding agency. The waiver must clearly document that the conflict of interest will not affect the integrity of the procurement process.

Enforcement and Remedies: Failure to comply with this Conflict of Interest Clause may result in disciplinary action, termination of employment or contracts, and other legal remedies. Contracts awarded in violation of this clause may be subject to cancellation, and the grantee may be required to repay any federal funds used in connection with such contracts.

Recipient must disclose in writing any conflict of interest to the Program Coordinator. The federal grantee shall periodically review procurement procedures and practices to ensure compliance with this Conflict of Interest Clause and shall take appropriate steps to address any issues that may arise.

13. Minimum Wages Under Executive Order 13658 (January 2015): In accordance with Executive Order 13658, the minimum wage that must be paid under any contract or subcontract awarded pursuant

to this Agreement is \$12.90 per hour, which must be adjusted annually during the term of this Agreement to meet the Secretary of Labor’s annual E.O. minimum wage Agreement.

ARTICLE XI – SIGNATURES

IN WITNESS WHEREOF, the parties hereto have executed this Agreement on the date(s) set forth below.

FOR THE RECIPIENT

CITY OF MUSCATINE

Name

Name

Title

Title

Date

Date



City of Muscatine

ITEM NUMBER 2026-0046

AGENDA ITEM SUMMARY

DATE: 2/3/2026

STAFF

Brian Stineman, Public Works Director

SUBJECT

Request to Approve Amendment #4 to the Lease Agreement for Farm Land on the Muscatine Municipal Airport Property.

EXECUTIVE SUMMARY

Request to approve Amendment #4 to the lease agreement for farm land on the Muscatine Municipal Airport property

STAFF RECOMMENDATION

Approve the request

BACKGROUND/DISCUSSION

The City owns and operates the Muscatine Municipal Airport on approximately 642 acres of real estate, of which 356 acres is either used for airport related activities or cannot be used for any other purpose. The remaining 286 acres is located within the airport fence and has been acquired to prevent construction within restricted aircraft approach zones. For the past 30 years, the city has leased this portion of the airport for agricultural purposes. The current leaseholder, Bartenhagen Farms, has continued to farm the property for more than 10 years, with the last lease negotiated and executed in 2012.

If the city wishes to lease a property for more than two years, a competitive process must be undergone, and current lessees are entitled to six months notice of intent to release a request for bids. Due to the proposed change in usage of some of the agricultural areas at the airport, a multi-year lease does not make sense at this time. Therefore, staff are proposing a one-year extension to the current lease with Bartenhagen Farms, which will extend the lease until December 31, 2026.

The planned construction of the joint-use training facility for the Muscatine Police Department and Muscatine County Sherriff's office has been canceled due to it being considered non-compliant with airport operations by the FAA. The return to the previous acreage is reflected in

Amendment #4 to the current agricultural lease. Staff propose keeping the lease rate the same at \$34,000 per year.

CITY FINANCIAL IMPACT

There is no negative impact to the budget to approve this agreement. The lease rate will remain at \$34,000 per year.

ATTACHMENTS

1. Bartenhagen Farms Lease Letter 2026
2. Ag Lease Amendment 4



1459 Washington St.
Muscatine, IA 52761-5040
(563) 263-8933
Fax (563) 263-2127

Public Works

City Transit 263-8152
Equipment Maintenance
Roadway Maintenance
Collection & Drainage
Building & Grounds
Engineering
Solid Waste
Airport

Fred, Roger, and Keith Bartenhagen Farms
9468 180th Street
Muscatine, IA 52761

January 20, 2026

RE: Muscatine Airport Farm Lease

Mr. Bartenhagen:

If you recall, last year we modified our lease agreement due to the City and Muscatine County's plans to construct a joint use training facility on a portion of the land that was currently farmed. Unfortunately this plan was rejected by the Federal Aviation Administration and therefore the plans have been scrapped. As such I am able to inform you that if you are interested you may farm the area that was proposed last year. At this time we are not changing the amount of the lease payments, however the available tillable area will revert to the "original" 255 acres.

I have included an amendment to the 2012 lease agreement. If you agree with this proposal please have your organization sign the document and return it to me and I will place it on the next available City Council agenda for their approval. We propose to make this a one year lease and will continue to move forward with yearly renewals until such a time as that becomes inappropriate.

In addition, if you have not already done so, please complete the annual water use report to the Iowa DNR and send me a copy via email or regular mail at your earliest convenience. This report is due by January 31, 2026.

If you have any questions or would like to discuss this matter further, please feel free to contact me via email or at the phone number below.

Sincerely,

Brian Stineman
Public Works Director
City of Muscatine
bstineman@muscatineiowa.gov
563-263-8933

**"I remember Muscatine for its sunsets. I have never seen any
on either side of the ocean that equaled them" — Mark Twain**

**AMENDMENT #4 TO LEASE AGREEMENT FOR AGRICULTURE LAND
AT THE MUSCATINE MUNICIPAL AIRPORT**

Whereas, the City of Muscatine entered into a lease agreement with Fred, Roger, and Keith Bartenhagen Farms (Lessee) effective the 1st day of January, 2012; and

Whereas, the lease was amended to extend the term through December 31, 2025; and

Whereas, both parties desire to extend the lease for 1 year;

Now therefore, the Lease Agreement is amended as follows:

Term: the lease shall terminate December 31, 2026. All other terms and conditions of the lease remain unchanged and enforceable.

City of Muscatine

Attest:

Dr. Brad Bark, Mayor

Matt Mardesen, City Administrator

Bartenhagen Farms



Fred Bartenhagen



Roger Bartenhagen



Keith Bartenhagen



City of Muscatine

ITEM NUMBER 2026-0047

AGENDA ITEM SUMMARY

DATE: 2/3/2026

STAFF

Mike Hartman, Fire Chief

SUBJECT

Request to Approve Issuance of a Purchase Order to Feld Fire for a Replacement Ambulance

EXECUTIVE SUMMARY

Presented for Council's consideration is a request to approve a Purchase Order for a Replacement Ambulance

STAFF RECOMMENDATION

It is recommended that the Purchase Order is approved

BACKGROUND/DISCUSSION

In October of 2025, a Muscatine Fire Department (MFD) ambulance was damaged in a vehicle collision. Inspection of the vehicle after the crash showed extensive damage to the structure of the vehicle and insurance adjusters assessed it as a total loss. The ambulance is needed in order to maintain MFD's ability to respond to emergency calls on a consistent basis. A new ambulance typically takes 18-24 months from order to completion. MFD staff were able to find an ambulance that was already in production for use as a demonstration vehicle. This purchase cut our lead time from the 18+ month timeframe to about 4 months. The insurance payout for the vehicle and equipment has been agreed upon and will cover all but about \$5000 of the total loss. This in-production ambulance will soon be completed, with a potential in-service date of late February. The request is to approve the purchase order for this replacement ambulance. This request is to issue a Purchase Order in the amount of \$297,000.00 to Feld Fire for the replacement ambulance.

CITY FINANCIAL IMPACT

With the insurance payment factored, the expected overall cost for this replacement will be roughly \$5000.

ATTACHMENTS

1. Replacement Ambulance bids 1.26

FIRE DEPARTMENT

Replacement Ambulance bids

| | | |
|-----------|--------------------------------|--------------|
| Feld Fire | Wheeled Coach Type I ambulance | \$297,000.00 |
| MacQueen | Demers Type I ambulance | \$352,785.00 |

**"I remember Muscatine for its sunsets. I have never seen any
on either side of the ocean that equaled them" — Mark Twain**